

PARTS LIST			
ITEM	QTY	PART NUMBER	DESCRIPTION
1	1	Base	
2	1	COLLAR	
3	1	SLIDING JAW	
4	1	WISE SCREW	
5	2	JAW PLATE	
6	2	SET SCREW	
7	2	SLIDE KEY	
8	1	SPECIAL KEY	
9	4	92210A540_18-8 Stainless Steel Hex Drive Flat Head Screw	STEP AP203

LEGEND:

- ∅ DIAMETER
- R RADIUS
- ° DEGREES
- ⌊ COUNTERBORE/SPOTFACE
- ∨ COUNTERSINK
- ∇ DEPTH
- CUBED



DIGITAL DESIGN
GRAPHICS
TECHNOLOGY

WWW.DDGT.NET

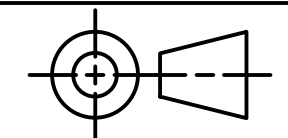

TOLERANCES UNLESS SPECIFIED:
DECIMAL INCHES:
X = ±.020
XX = ±.010
XXX = ±.005
FRACTIONAL ±1/64"
ANGLES ±1 DEGREE
SURFACES 32✓

CLASS: DDGT240

PAGE #: XX

INVENTOR DRAWING NAME:
MACHINE VISE

FIG #: FIG # 14.71

MANAGER: G. STROMMEN

DRAFTER: pbusc

DATE: 12/10/2025

SCALE: AS NOTED

PAGE #: 1 OF 7

GENERAL NOTES:
GENERAL NOTES GO HERE

MACHINE VISE
SCALE 1:1

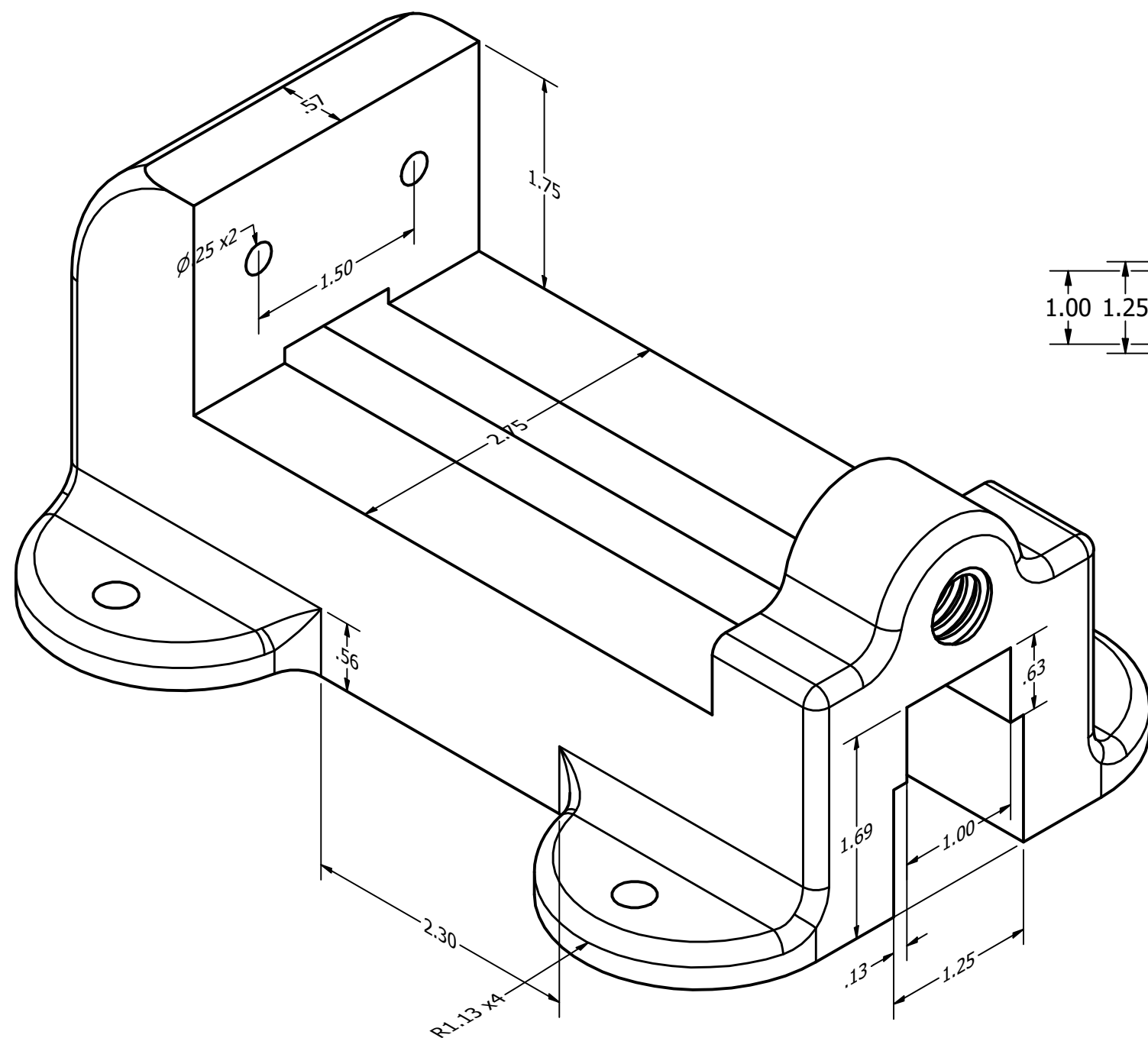

BASE
SCALE 1:1

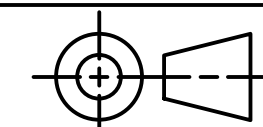
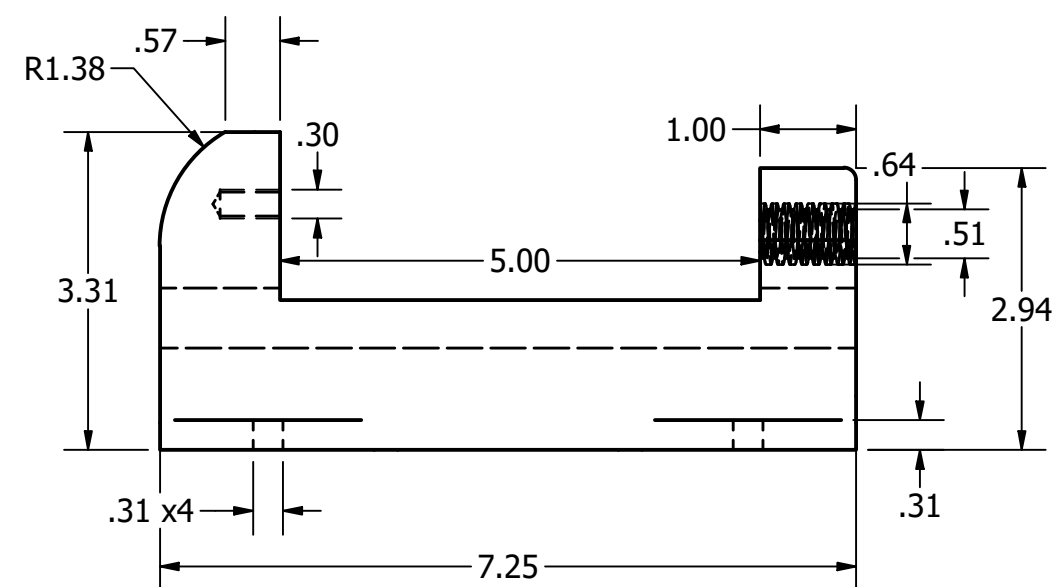
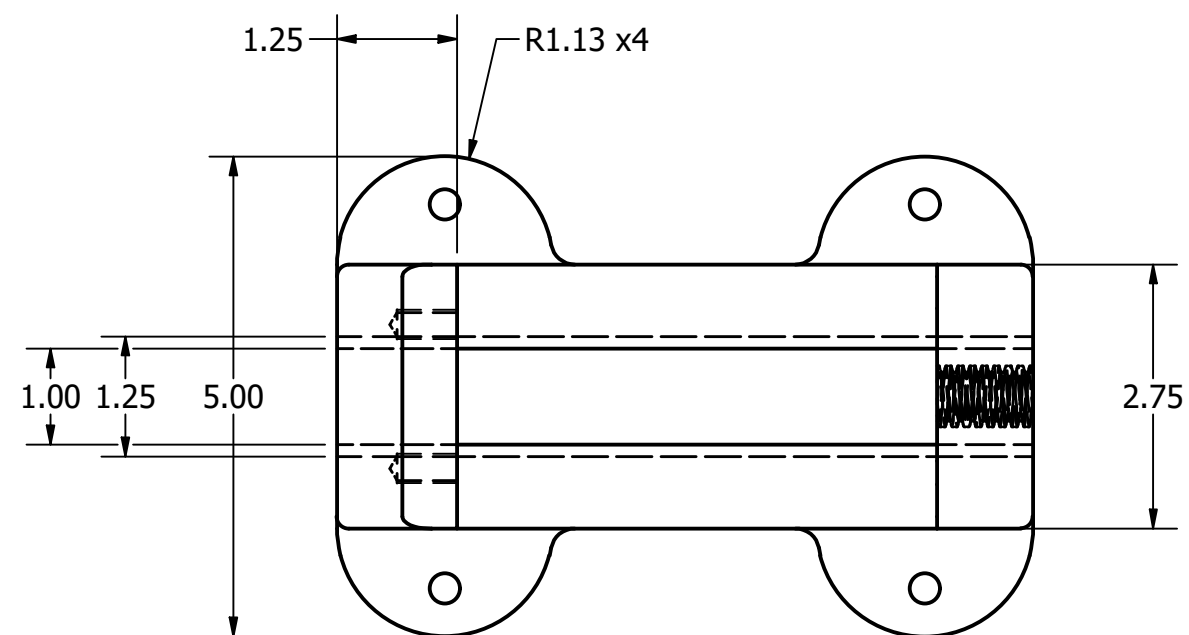

TOLERANCES UNLESS SPECIFIED:
DECIMAL INCHES:
X = ±.020
XX = ±.010
XXX = ±.005
FRACTIONAL ±1/64"
ANGLES ±1 DEGREE
SURFACES 32 ✓

CLASS: DDGT240

PAGE #: XX

INVENTOR DRAWING NAME:
MACHINE VISE

FIG #: FIG # 14.71

MANAGER: G. STROMMEN

DRAFTER: pbusc

DATE: 12/10/2025

SCALE: AS NOTED

PAGE #: 2 OF 7

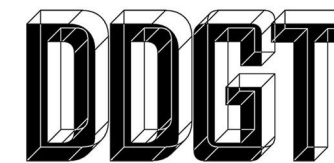

DIGITAL DESIGN
GRAPHICS
TECHNOLOGY

WWW.DDGT.NET

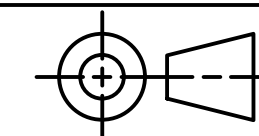

TOLERANCES UNLESS SPECIFIED:
DECIMAL INCHES:
X = ±.020
XX = ±.010
XXX = ±.005
FRACTIONAL ±1/64"
ANGLES ±1 DEGREE
SURFACES $\sqrt{32}$

CLASS: DDGT240

PAGE #: XX

INVENTOR DRAWING NAME:
MACHINE VISE

FIG #: FIG # 14.71

MANAGER: G. STROMMEN

DRAFTER: pbusc

DATE: 12/10/2025

SCALE: AS NOTED

PAGE #: 3 OF 7

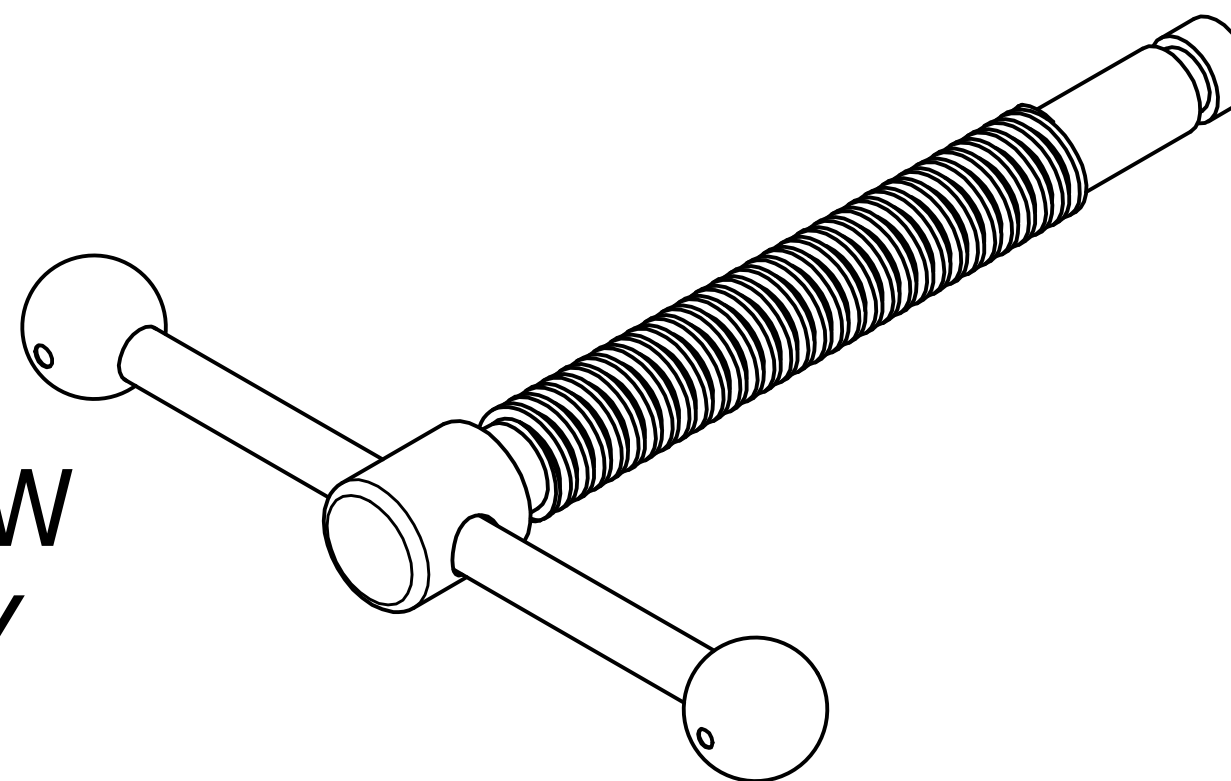
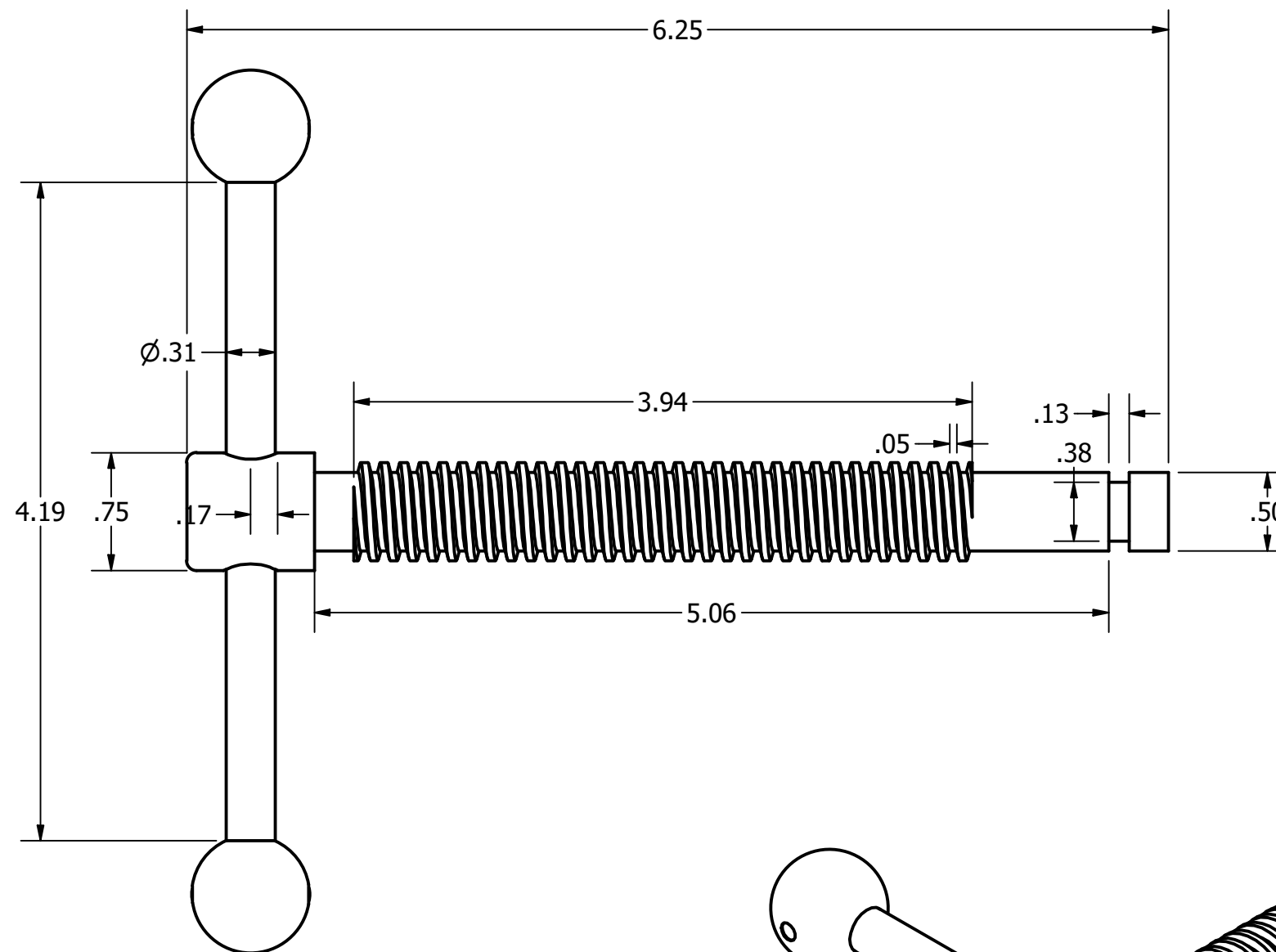

WISE SCREW ASSEMBLY SCALE 1:1

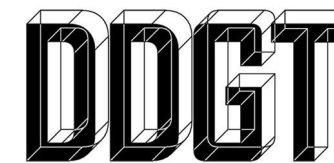

DIGITAL DESIGN
GRAPHICS
TECHNOLOGY

WWW.DDGT.NET

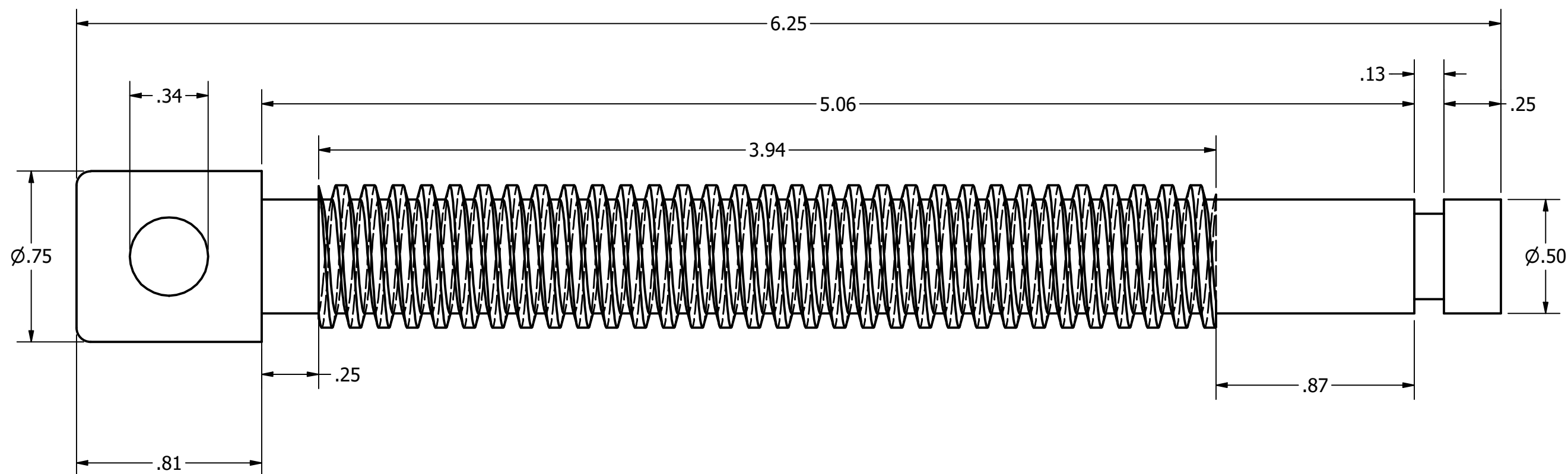

WISE SCREW SCALE 4:1

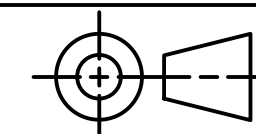

TOLERANCES UNLESS SPECIFIED:
DECIMAL INCHES:
X = ±.020
XX = ±.010
XXX = ±.005
FRACTIONAL ±1/64"
ANGLES ±1 DEGREE

SURFACES $\sqrt{32}$

CLASS: DDGT240

PAGE #: XX

INVENTOR DRAWING NAME:
MACHINE VISE

FIG #: FIG # 14.71

MANAGER: G. STROMMEN

DRAFTER: pbusc

DATE: 12/10/2025

SCALE: AS NOTED

PAGE #: 4 OF 7

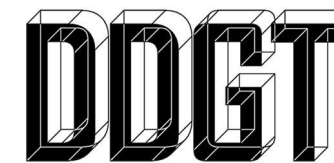

DIGITAL DESIGN
GRAPHICS
TECHNOLOGY

WWW.DDGT.NET

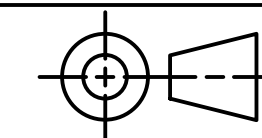
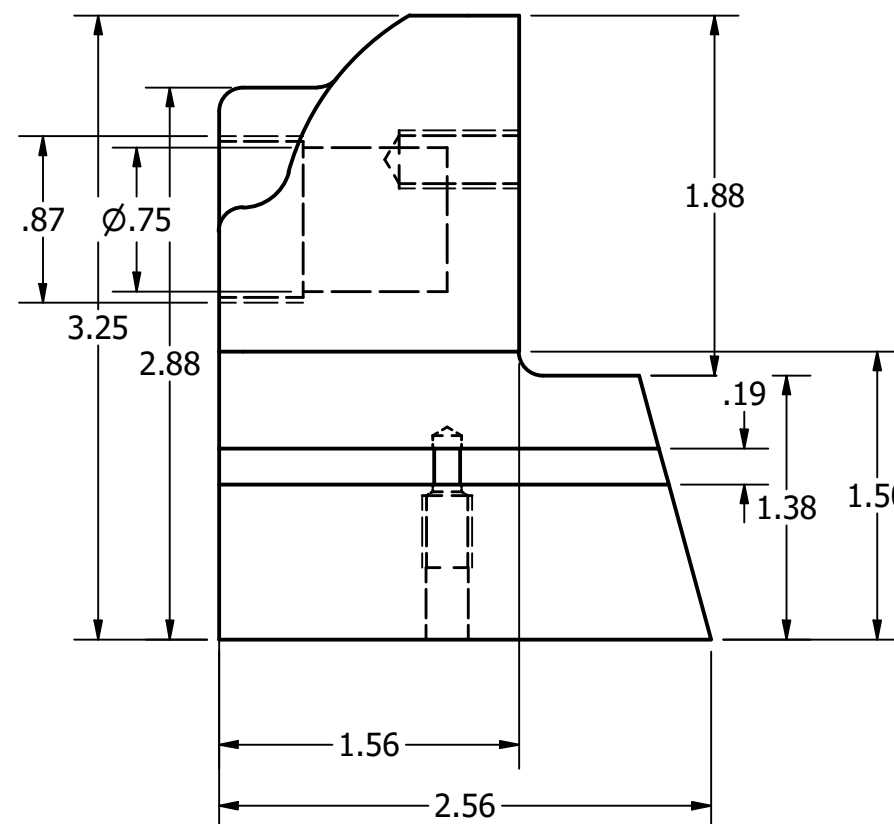
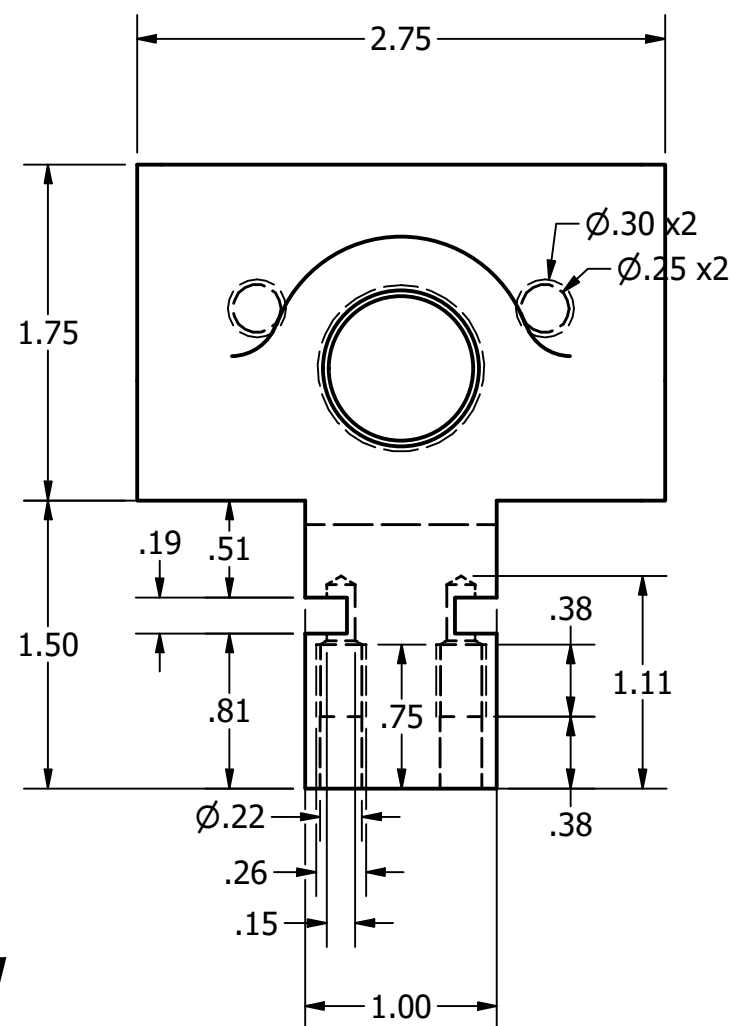
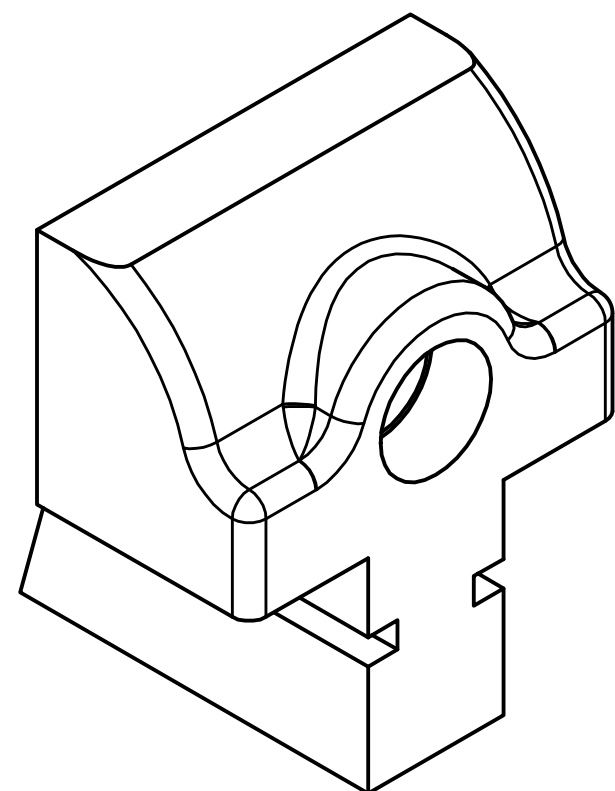

TOLERANCES UNLESS SPECIFIED:
DECIMAL INCHES:
X = ±.020
XX = ±.010
XXX = ±.005
FRACTIONAL ±1/64"
ANGLES ±1 DEGREE
SURFACES $\sqrt{32}$

CLASS: DDGT240

PAGE #: XX

INVENTOR DRAWING NAME:
MACHINE VISE

FIG #: FIG # 14.71

MANAGER: G. STROMMEN

DRAFTER: pbusc

DATE: 12/10/2025

SCALE: AS NOTED

PAGE #: 5 OF 7

SLIDING JAW SCALE 1:1

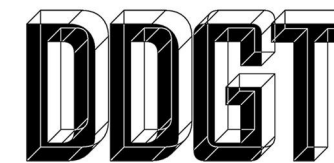

DIGITAL DESIGN
GRAPHICS
TECHNOLOGY

WWW.DDGT.NET

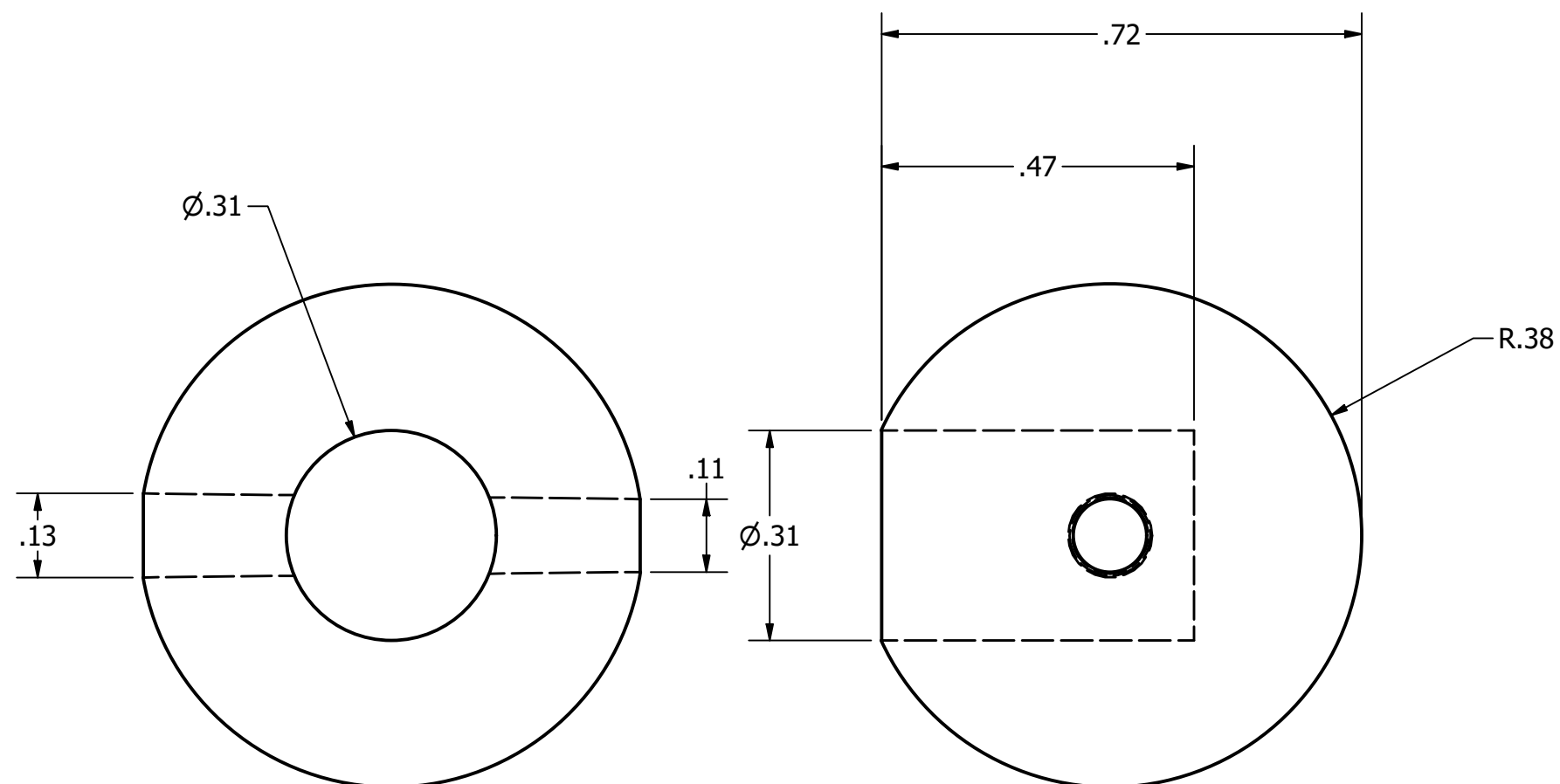

HANDLE BALL SCALE 4:1

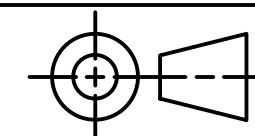

TOLERANCES UNLESS SPECIFIED:
DECIMAL INCHES:
X = $\pm.020$
XX = $\pm.010$
XXX = $\pm.005$
FRACTIONAL $\pm 1/64$ "
ANGLES ± 1 DEGREE
SURFACES $\sqrt{32}$

CLASS: DDGT240

PAGE #: XX

INVENTOR DRAWING NAME:
MACHINE VISE

FIG #: FIG # 14.71

MANAGER: G. STROMMEN

DRAFTER: pbusc

DATE: 12/10/2025

SCALE: AS NOTED

PAGE #: 6 OF 7

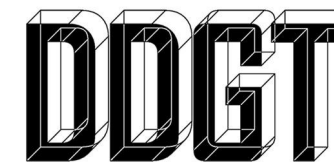

DIGITAL DESIGN
GRAPHICS
TECHNOLOGY

WWW.DDGT.NET

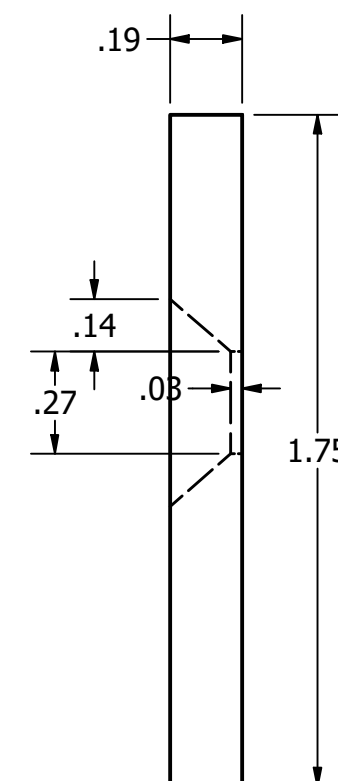
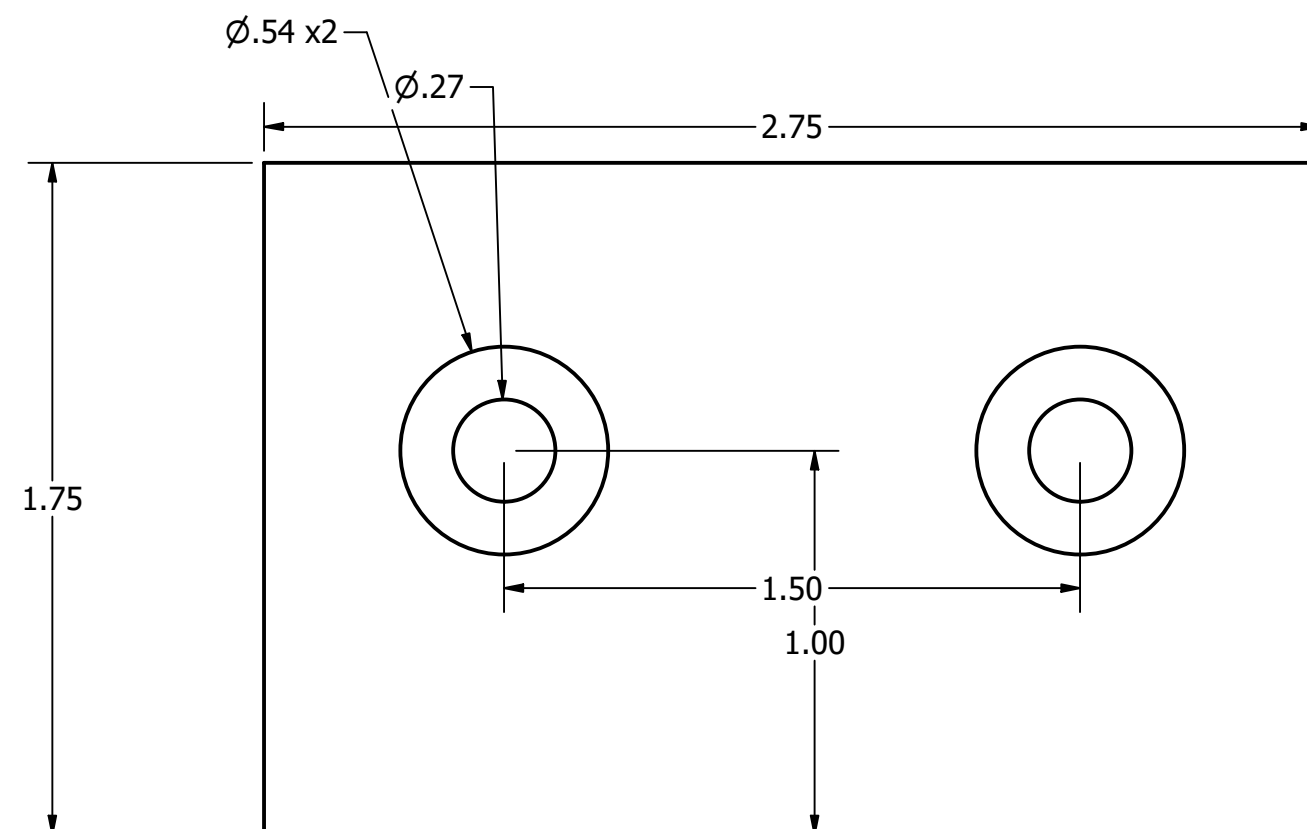

JAW PLATE
SCALE 2:1

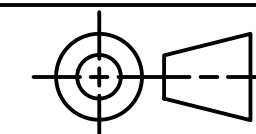

TOLERANCES UNLESS SPECIFIED:
DECIMAL INCHES:
X = ±.020
XX = ±.010
XXX = ±.005
FRACTIONAL ±1/64"
ANGLES ±1 DEGREE

SURFACES 32 ✓

CLASS: DDGT240

PAGE #: XX

INVENTOR DRAWING NAME:
MACHINE VISE

FIG #: FIG # 14.71

MANAGER: G. STROMMEN

DRAFTER: pbusc

DATE: 12/10/2025

SCALE: AS NOTED

PAGE #: 7 OF 7