

PARTS LIST				
ITEM	QTY	PART NUMBER	MATERIAL	DESCRIPTION
1	1	AXLE	STEEL	
2	1	BUSHING	BRONZE	OILESS
3	1	HUB	ALUMINUM	
4	1	COLLAR	ALUMINUM	
5	2	PANEL RING	ALUMINUM	.12" UNIFORM THICKNESS
6	1	WHEEL	HARD RUBBER	
7	6	RIVET	STANDARD	ø.31 , 1.00" INSIDE LENGTH, EQUALLY SPACED (MCMASTER-CARR 97300A709)
8	2	WASHER	STANDARD	I.D. ø1.00", O.D.ø2.12",.18" THICK
9	1	98296A932_1050-1095 Spring Steel Slotted Spring Pin	STANDARD	ø.25",1.875" LONG (MCMASTER-CARR 98296A932)



DIGITAL DESIGN  
GRAPHICS  
TECHNOLOGY

WWW.DDGT.NET

**LEGEND:**

- ∅ DIAMETER
- R RADIUS
- ° DEGREES

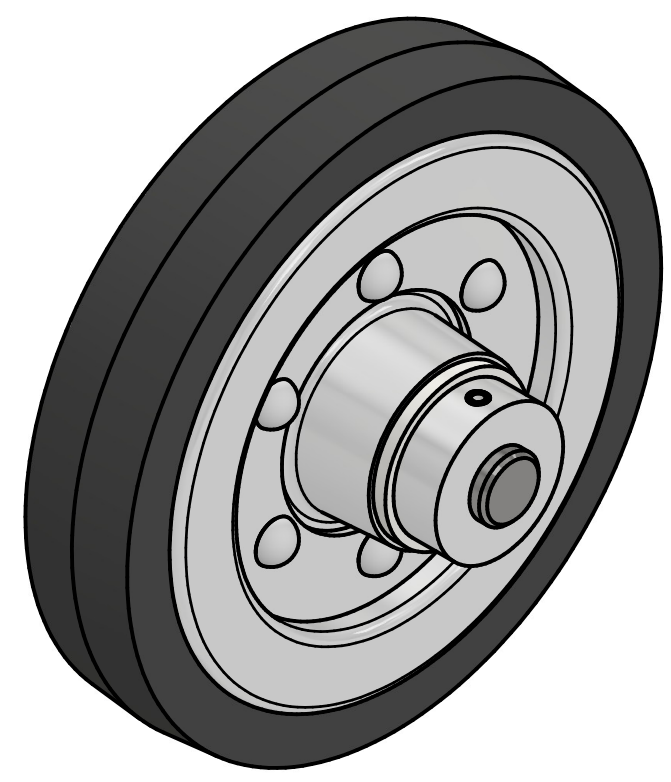

WHEEL ASSEMBLY  
SCALE 1 / 2

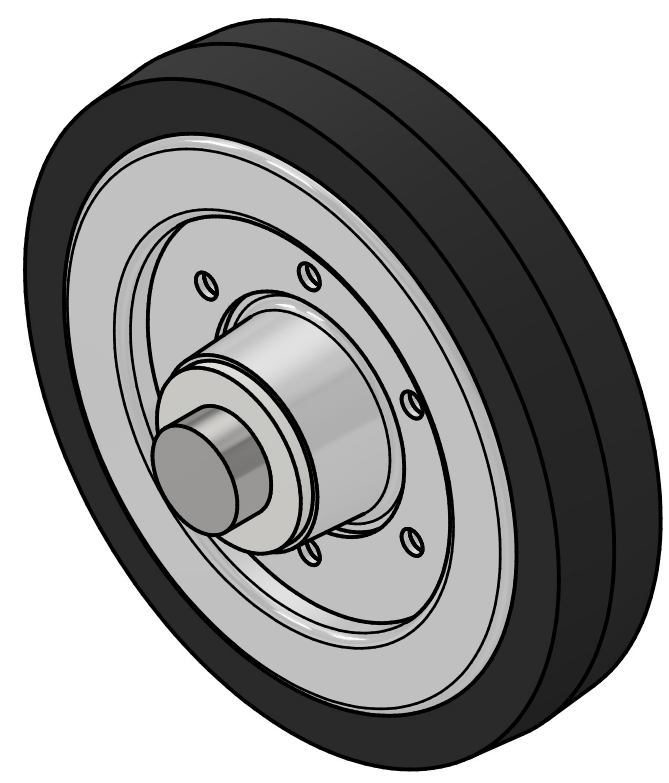

WHEEL ASSEMBLY (ALT VIEW)  
SCALE 1 / 2

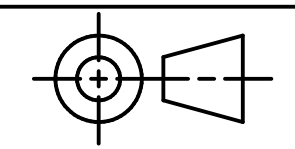

TOLERANCES UNLESS SPECIFIED:  
DECIMAL INCHES:  
X = ±.020  
XX = ±.010  
XXX = ±.005  
FRACTIONAL ±1/64"  
ANGLES ± 1 DEGREE  
SURFACES <sup>32</sup>✓

**GENERAL NOTES:**

ALL FILETS HAVE R.12 UNLESS OTHERWISE NOTED  
ALL CHAMFERS ARE .06" X 45° UNLESS OTHERWISE NOTED

CLASS:	DDGT121
ASSIGNMENT #:	10
INVENTOR DRAWING NAME:	WHEEL ASSEMBLY
FIG #:	11-55
MANAGER:	G. STROMMEN
DRAFTER:	M. ALCANTARA
DATE:	2/3/2026
SCALE:	AS NOTED
PAGE #:	1 OF 3

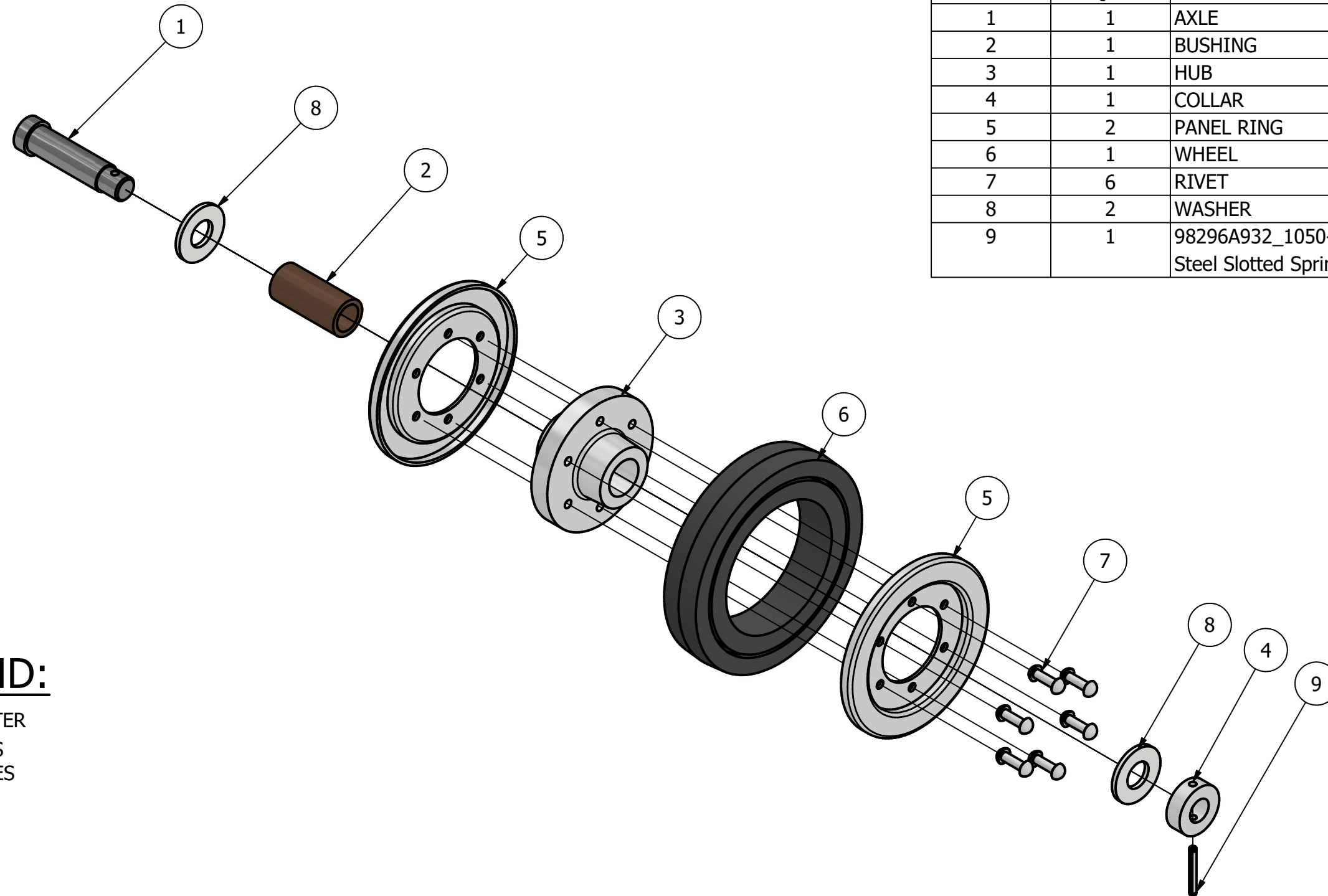

PARTS LIST		
ITEM	QTY	PART NUMBER
1	1	AXLE
2	1	BUSHING
3	1	HUB
4	1	COLLAR
5	2	PANEL RING
6	1	WHEEL
7	6	RIVET
8	2	WASHER
9	1	98296A932_1050-1095 Spring Steel Slotted Spring Pin



DIGITAL DESIGN  
GRAPHICS  
TECHNOLOGY

WWW.DDGT.NET

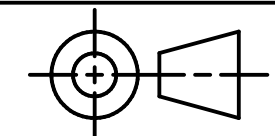

TOLERANCES UNLESS SPECIFIED:  
DECIMAL INCHES:  
X = ±.020  
XX = ±.010  
XXX = ±.005  
FRACTIONAL ±1/64"  
ANGLES ± 1 DEGREE  
SURFACES <sup>32</sup>✓

CLASS: DDGT121

ASSIGNMENT #: 10

INVENTOR DRAWING NAME:  
WHEEL ASSEMBLY

FIG #: 11-55

MANAGER: G. STROMMEN

DRAFTER: M. ALCANTARA

DATE: 2/3/2026

SCALE: AS NOTED

PAGE #: 2 OF 3

**LEGEND:**

- ∅ DIAMETER
- R RADIUS
- ° DEGREES

WHEEL EXPLODED ASSEMBLY  
SCALE 1 / 4

**GENERAL NOTES:**

ALL FILETS HAVE R.12 UNLESS OTHERWISE NOTED  
ALL CHAMFERS ARE .06" X 45° UNLESS OTHERWISE NOTED

PARTS LIST		
ITEM	QTY	PART NUMBER
1	1	AXLE
2	1	BUSHING
3	1	HUB
4	1	COLLAR
5	2	PANEL RING
6	1	WHEEL
7	6	RIVET
8	2	WASHER
9	1	98296A932_1050-1095 Spring Steel Slotted Spring Pin



DIGITAL DESIGN  
GRAPHICS  
TECHNOLOGY

WWW.DDGT.NET

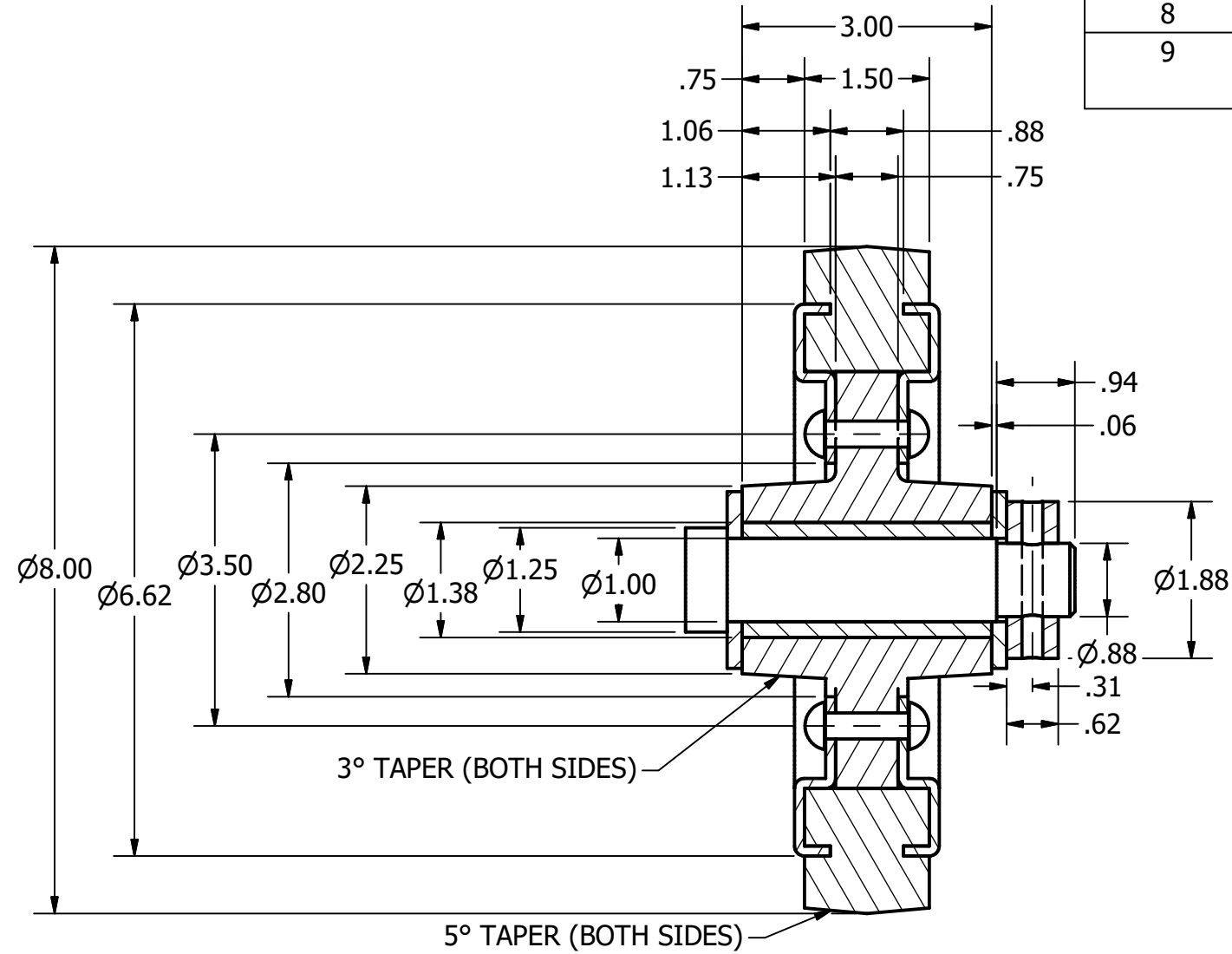

WHEEL SECTION VIEW  
SCALE 1 / 2 / .

**LEGEND:**

- Ø DIAMETER
- R RADIUS
- ° DEGREES

**GENERAL NOTES:**

ALL FILETS HAVE R.12 UNLESS OTHERWISE NOTED  
ALL CHAMFERS ARE .06" X 45° UNLESS OTHERWISE NOTED

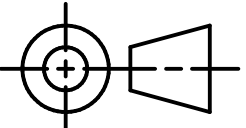

TOLERANCES UNLESS SPECIFIED:  
DECIMAL INCHES:  
X = ±.020  
XX = ±.010  
XXX = ±.005  
FRACTIONAL ±1/64"  
ANGLES ± 1 DEGREE  
SURFACES <sup>32</sup> ✓

CLASS:	DDGT121
ASSIGNMENT #:	10
INVENTOR DRAWING NAME:	WHEEL ASSEMBLY
FIG #:	11-55
MANAGER:	G. STROMMEN
DRAFTER:	M. ALCANTARA
DATE:	2/3/2026
SCALE:	AS NOTED
PAGE #:	3 OF 3