

4

3

2

1

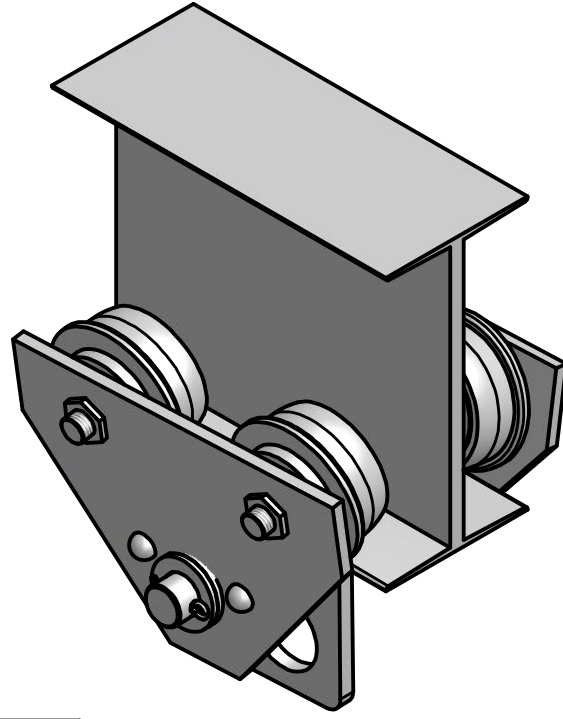
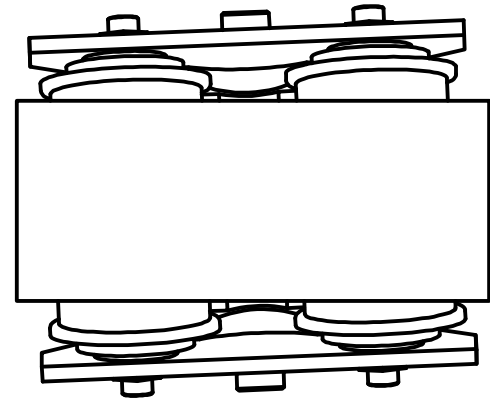

PARTS LIST			
ITEM	QTY	PART NUMBER	MATERIAL
1	2	SIDE PLATE	MST
2	2	GUIDE	CI
3	4	BUTTON HEAD REVIT	
4	4	LOCKNUT M16	
5	4	WHEEL	CI
6	4	P4 AXLE	CRS
7	44	ROLLER BEARING	CRS
8	4	WASHER OD 65	
9	12	WASHER OD 44	
10	1	I BEAM	S200X34
11	1	P3 AXLE	CRS
12	1	SMALL PLATE	
13	2	COTTER PIN	
14	2	SIDE PLATE ASSEMBLY	
15	4	WHEEL ASSEMBLY	

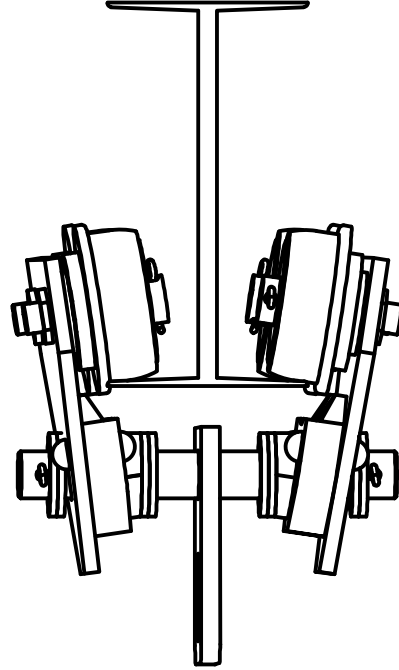
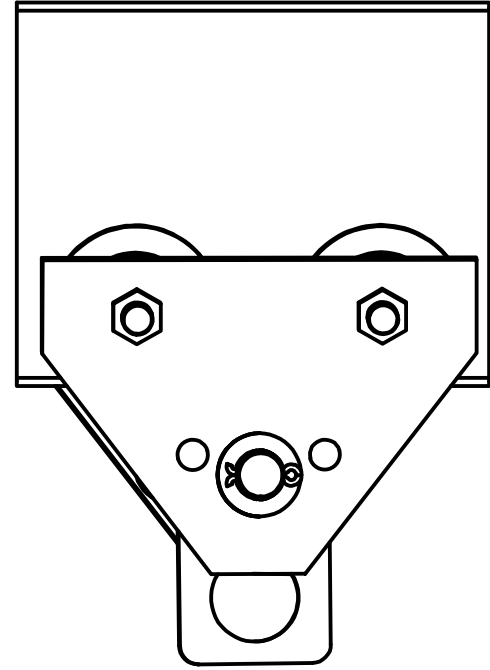

TROLLEY
SCALE 1 / 4

DRAWN	SAEDA TILLMON	2/8/2010	TITLE TROLLEY ASSEMBLY		
CHECKED					
QA					
MFG					
APPROVED			SIZE	DWG NO	REV
			B	Fig 14-83	
SCALE			SHEET 1 OF 9		

4

3

2

1

B

B

A

A

TROLLEY SHOULD BE MOUNTED ON A S200 X 34 I BEAM
 ADJUSTABLE WASHER 26 ID X 44 OD X 4 THK, 12 REQD, MATL-STL
 RIVET, BUTTON HEAD, Ø10 X 60 LG, 4 REQD
 WASHER 26 ID X 65 OD X 3 THK, 4 REQD
 PREVAILING TORQUE INSERT-TYPE LOCKNUT M16 X 2, 4 REQD
 COTTER PIN Ø6 X 40 LG, 6 REQD

PARTS LIST		
ITEM	QTY	PART NUMBER
1	2	SIDE PLATE
10	1	I BEAM
11	1	P3 AXLE
12	1	SMALL PLATE
13	2	COTTER PIN
2	2	GUIDE
3	4	BUTTON HEAD REVIT
4	4	LOCKNUT M16
5	4	WHEEL
6	4	P4 AXLE
7	44	ROLLER BEARING
8	4	WASHER OD 65
9	12	WASHER OD 44
14	2	SIDE PLATE ASSEMBLY
15	4	WHEEL ASSEMBLY

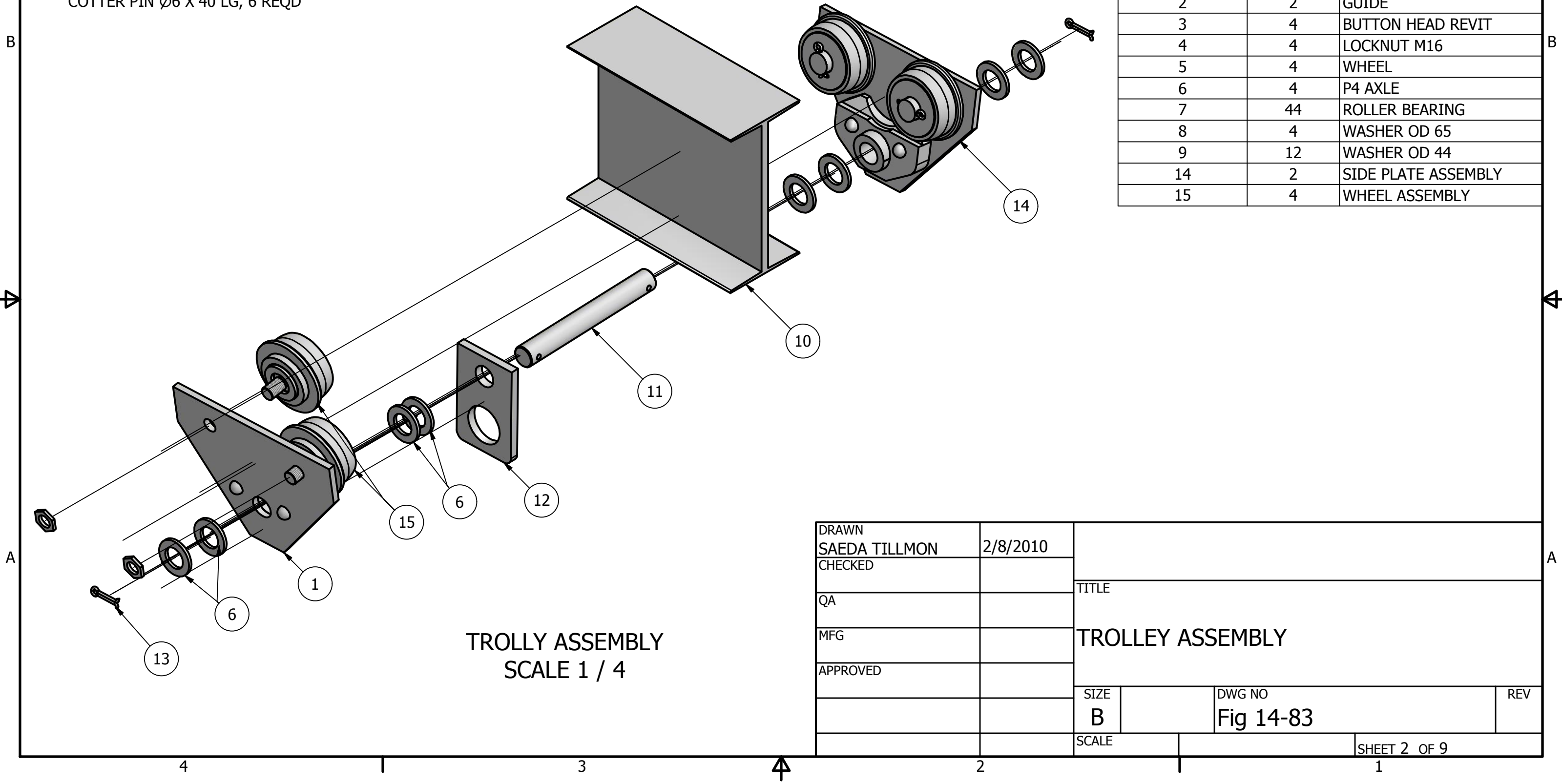

TROLLEY ASSEMBLY
 SCALE 1 / 4

DRAWN	SAEDA TILLMON	2/8/2010		
CHECKED			TITLE	
QA			TROLLEY ASSEMBLY	
MFG				
APPROVED				
		SIZE	DWG NO	REV
		B	Fig 14-83	
		SCALE	SHEET 2 OF 9	

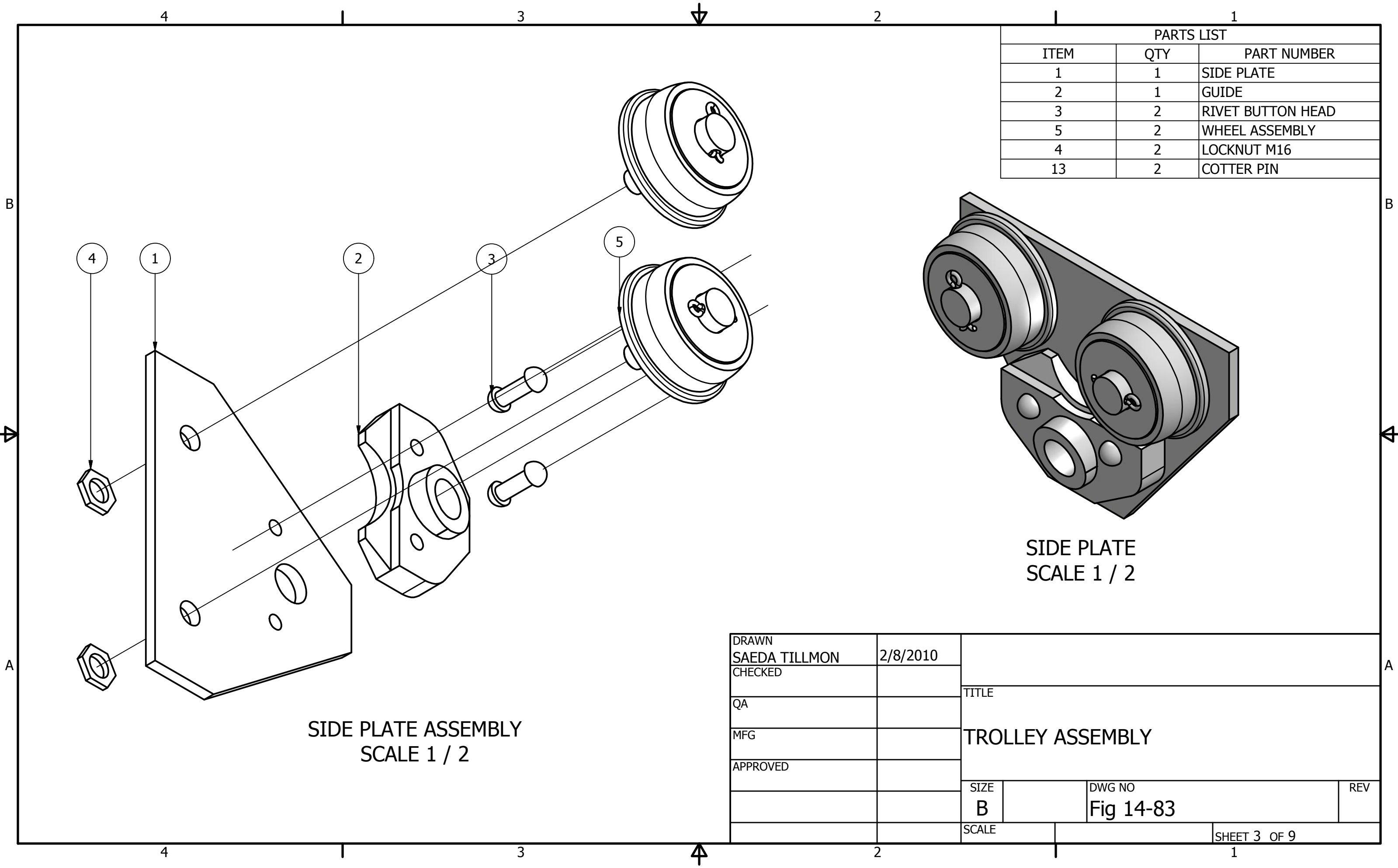

PARTS LIST		
ITEM	QTY	PART NUMBER
1	1	SIDE PLATE
2	1	GUIDE
3	2	RIVET BUTTON HEAD
5	2	WHEEL ASSEMBLY
4	2	LOCKNUT M16
13	2	COTTER PIN

SIDE PLATE ASSEMBLY
SCALE 1 / 2

SIDE PLATE
SCALE 1 / 2

DRAWN SAEDA TILLMON	2/8/2010	TITLE TROLLEY ASSEMBLY		
CHECKED				
QA				
MFG				
APPROVED		SIZE B	DWG NO Fig 14-83	REV
		SCALE	SHEET 3 OF 9	

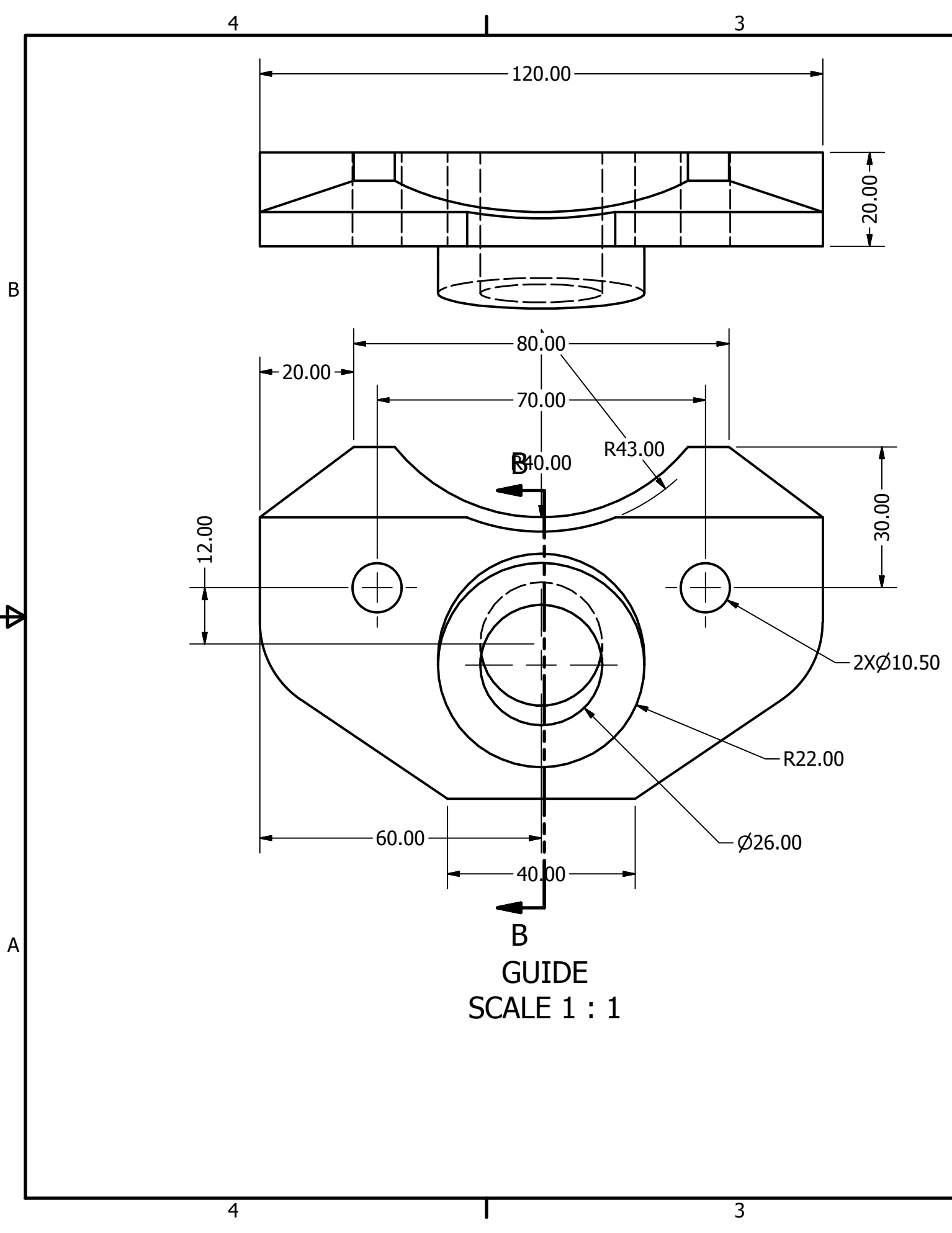

PARTS LIST			
ITEM	QTY	PART NUMBER	MATERIAL
2	2	GUIDE	CI

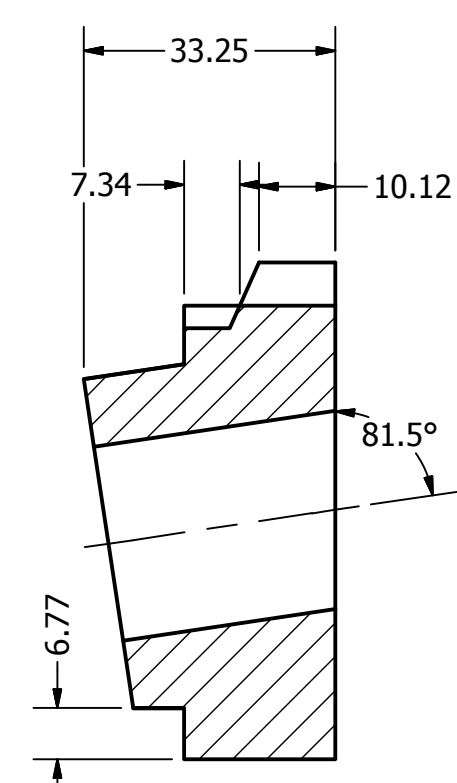

SECTION B-B
SCALE 1 : 1

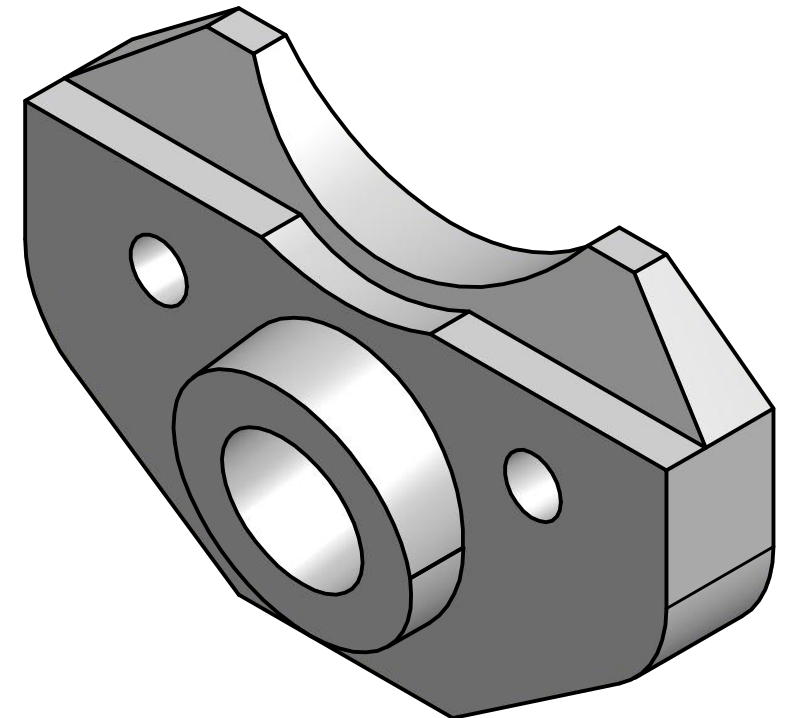

DRAWN	SAEDA TILLMON	2/8/2010		
CHECKED				
QA			TITLE	
MFG			TROLLEY ASSEMBLY	
APPROVED				
			SIZE	DWG NO
			B	Fig 14-83
			SCALE	REV

PARTS LIST		
ITEM	QTY	PART NUMBER
1	2	SIDE PLATE

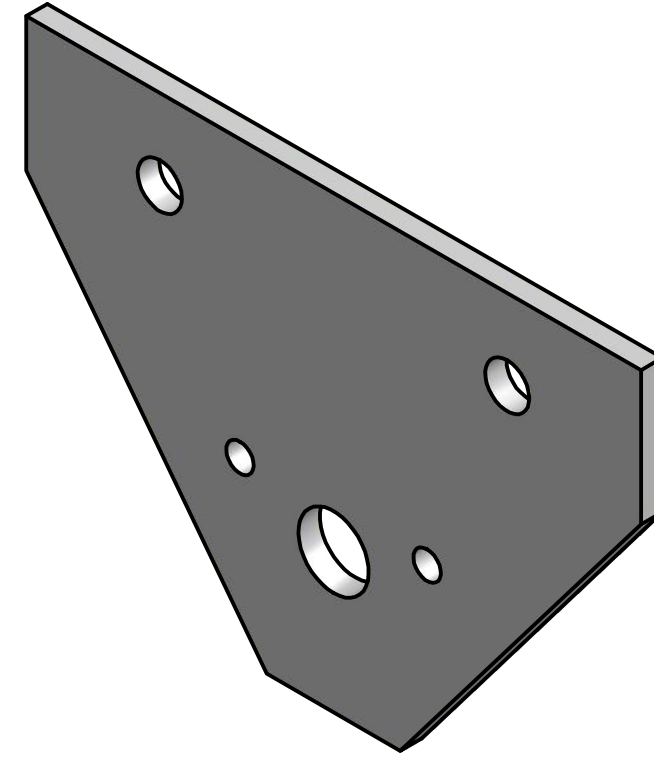
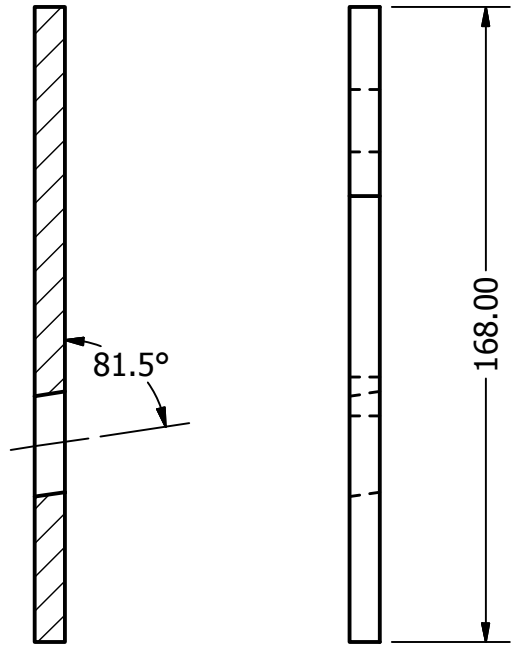
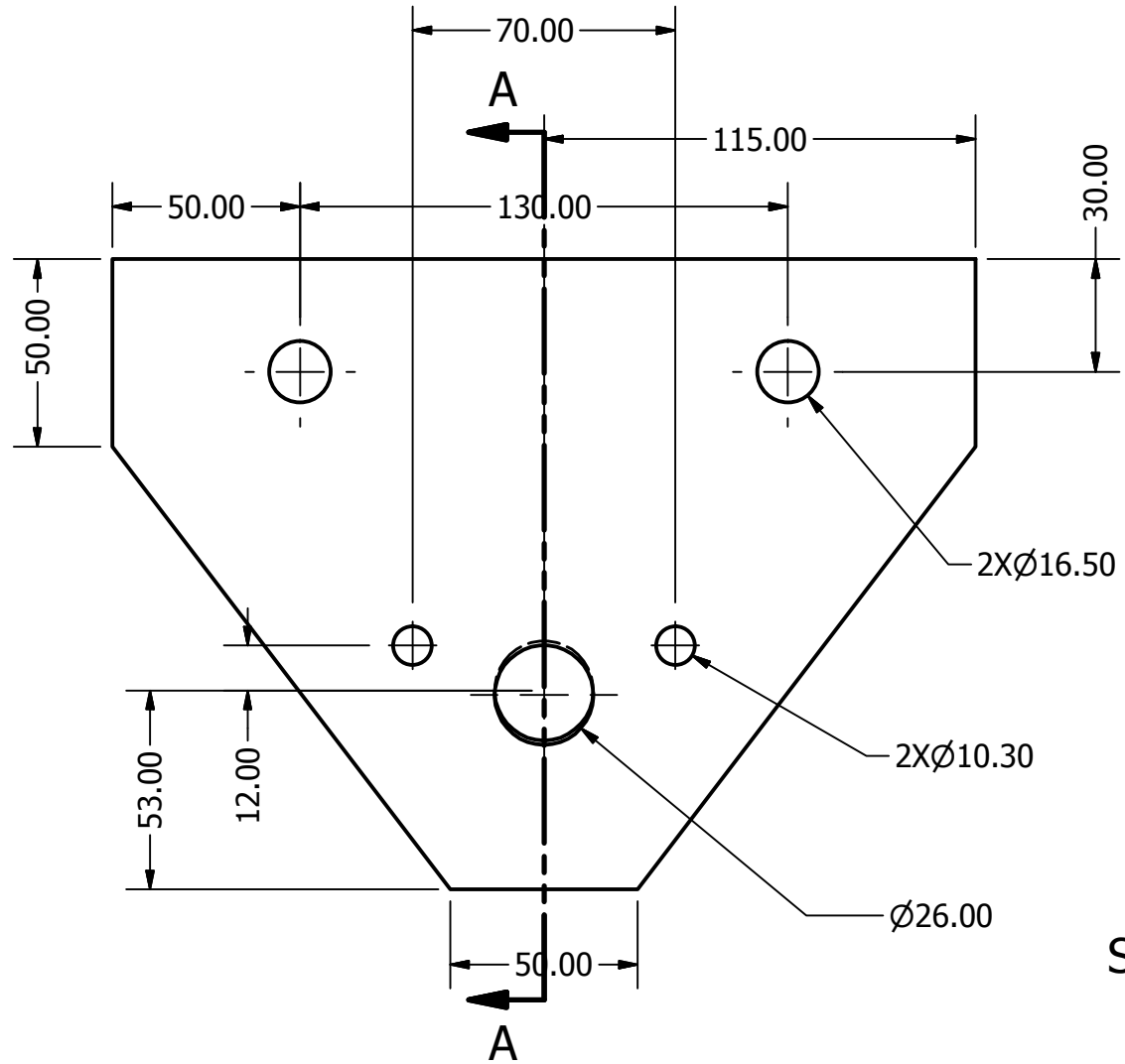
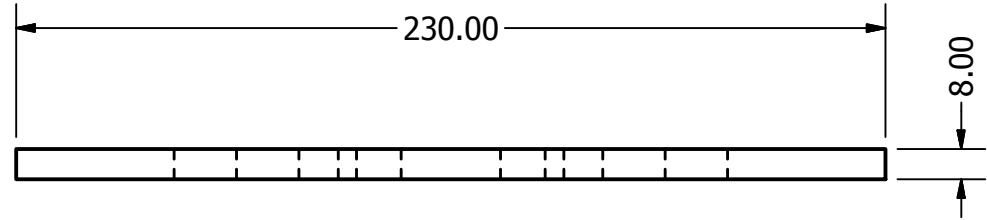

SIDE PLATE
SCALE 1 / 2

DRAWN	SAEDA TILLMON	2/8/2010	TITLE	
CHECKED			TROLLEY ASSEMBLY	
QA			SIZE	DWG NO
MFG			B	Fig 14-83
APPROVED			SCALE	REV

4

3

2

1

PARTS LIST		
ITEM	QTY	PART NUMBER
6	1	AXLE P4
7	11	ROLLER BEARING
5	1	WHEEL
8	1	65 OD WASHER
9	1	44 OD WASHER
13	1	COTTER PIN

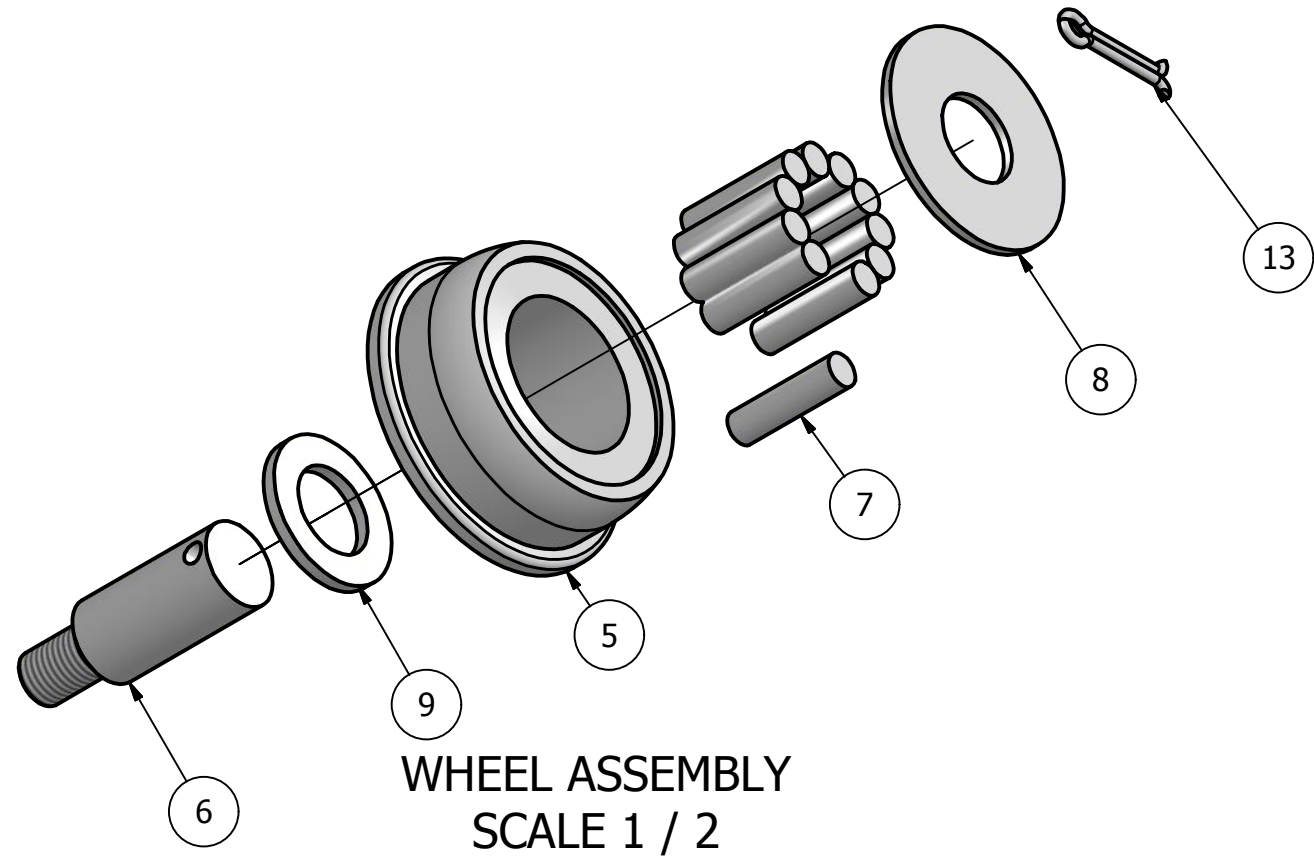

DRAWN	SAEDA TILLMON	2/8/2010		
CHECKED			TITLE	
QA			TROLLEY ASSEMBLY	
MFG				
APPROVED				
		SIZE	DWG NO	REV
		B	Fig 14-83	
		SCALE	SHEET 6 OF 9	

4

3

2

1

B

B

A

A

PARTS LIST		
ITEM	QTY	PART NUMBER
5	4	WHEEL

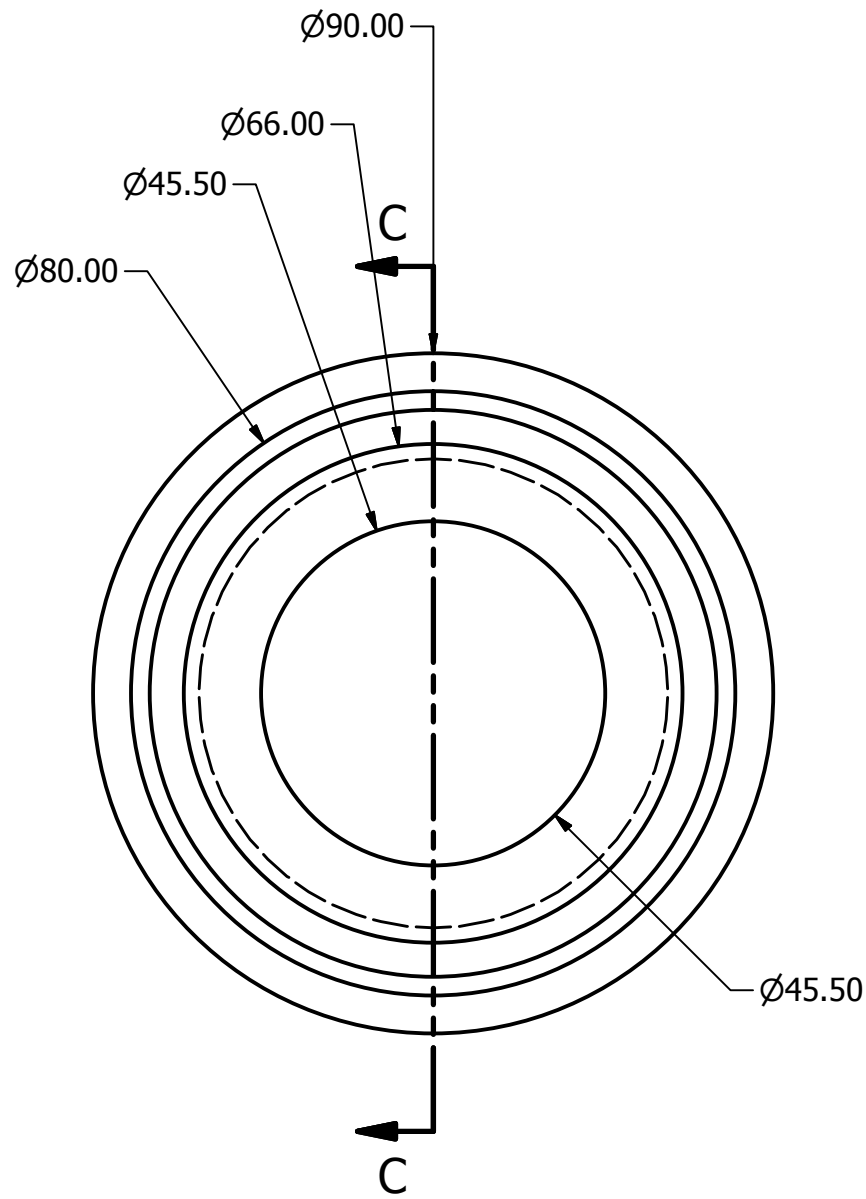

WHEEL
SCALE 1 : 1

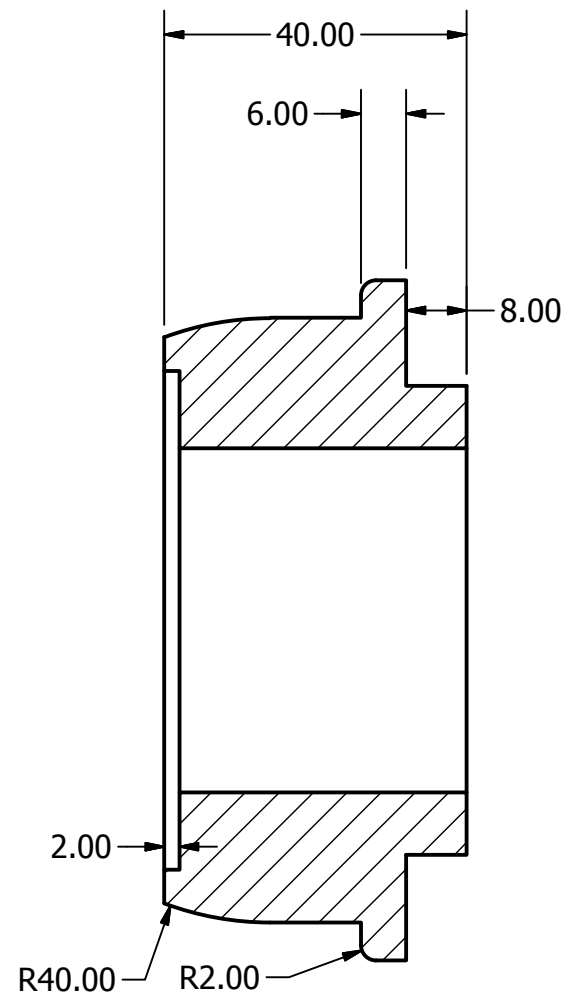

SECTION C-C
SCALE 1 : 1

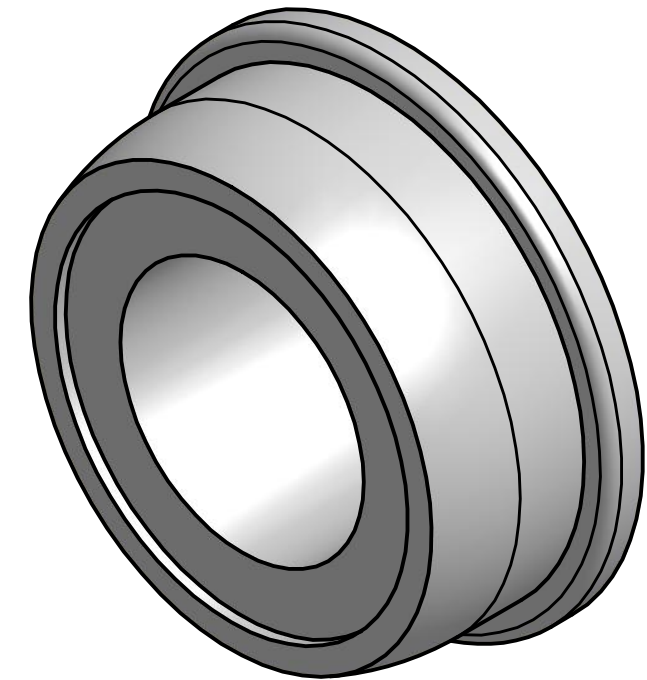

DRAWN	SAEDA TILLMON	2/8/2010		
CHECKED			TITLE	
QA			TROLLEY ASSEMBLY	
MFG				
APPROVED				
		SIZE	DWG NO	REV
		B	Fig 14-83	
		SCALE	SHEET 7 OF 9	

PARTS LIST		
ITEM	QTY	PART NUMBER
6	4	AXLE P4
7	44	ROLLER BEARING

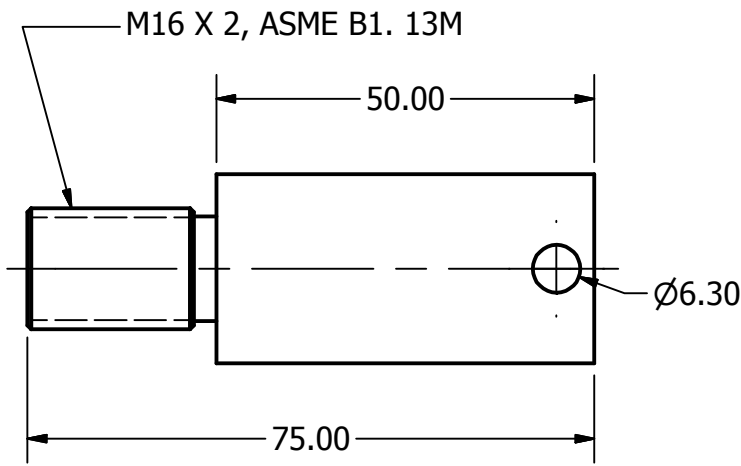
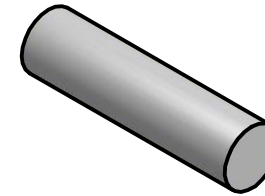
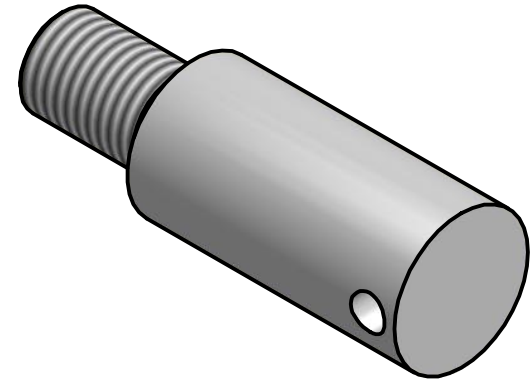

WHEEL AXLE
SCALE 1 : 1

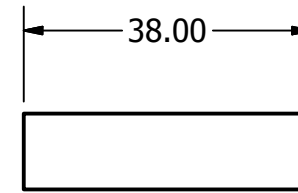
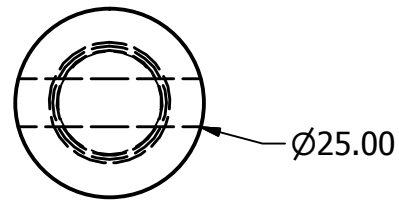

ROLLER BEARINGS
SCALE 1 : 1

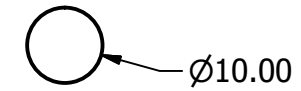

DRAWN	SAEDA TILLMON	2/8/2010		
CHECKED			TITLE	
QA			TROLLEY ASSEMBLY	
MFG				
APPROVED				
		SIZE	DWG NO	REV
		B	Fig 14-83	
		SCALE	SHEET 8 OF 9	

PARTS LIST		
ITEM	QTY	PART NUMBER
11	1	P3 AXLE
12	1	SMALL PLATE

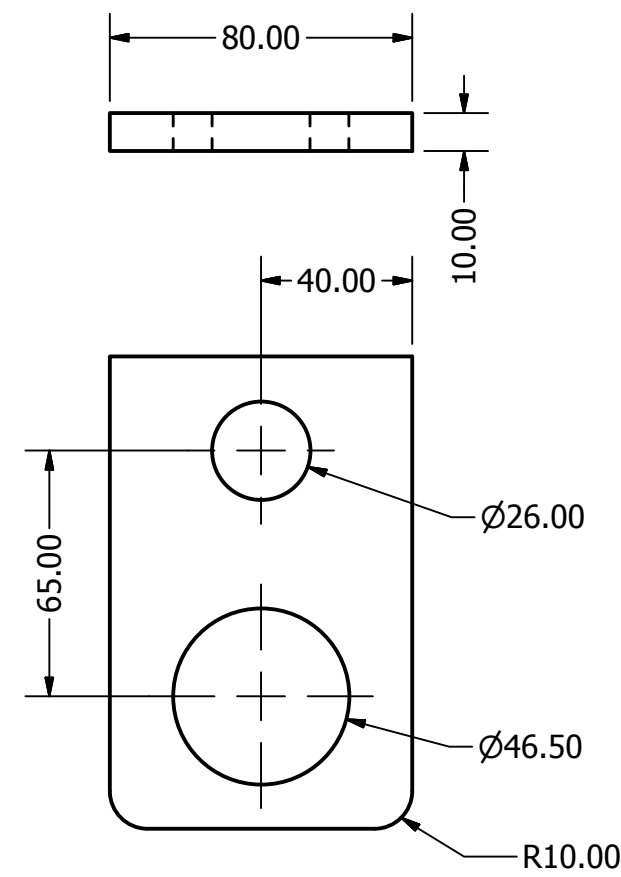

SMALL PLATE
SCALE 1 / 2

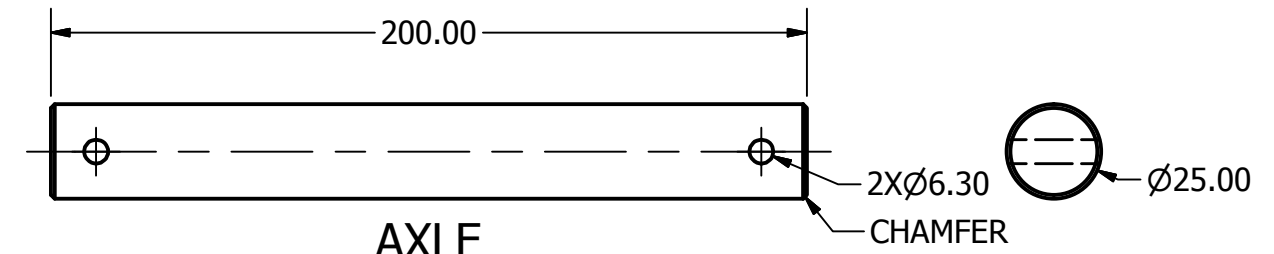
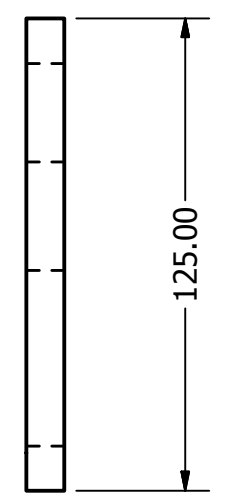
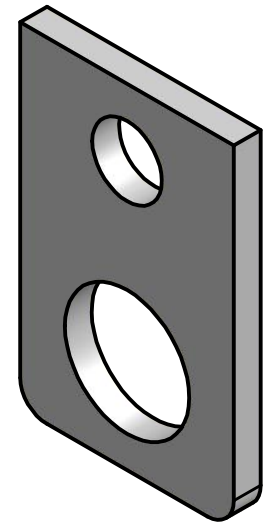

AXLE
SCALE 1 / 2

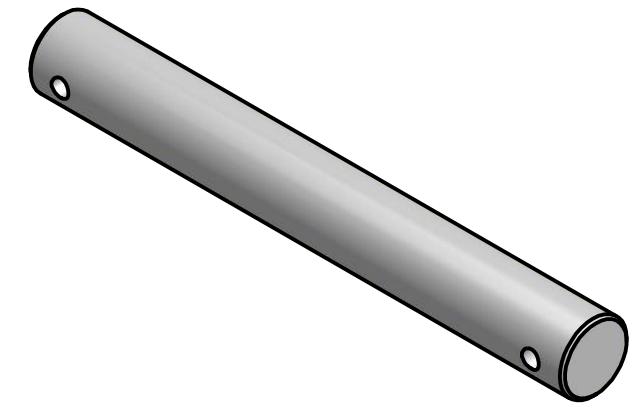

DRAWN	SAEDA TILLMON	2/8/2010	TITLE	
CHECKED			TROLLEY ASSEMBLY	
QA			SIZE	DWG NO
MFG			B	Fig 14-83
APPROVED			SCALE	REV
			SHEET 9 OF 9	