

PARTS LIST			
ITEM	QTY	PART NUMBER	MATERIAL
1	1	Part1	Ductile Iron
2	1	Part2	Ductile Iron
3	4	Part3	Ductile Iron

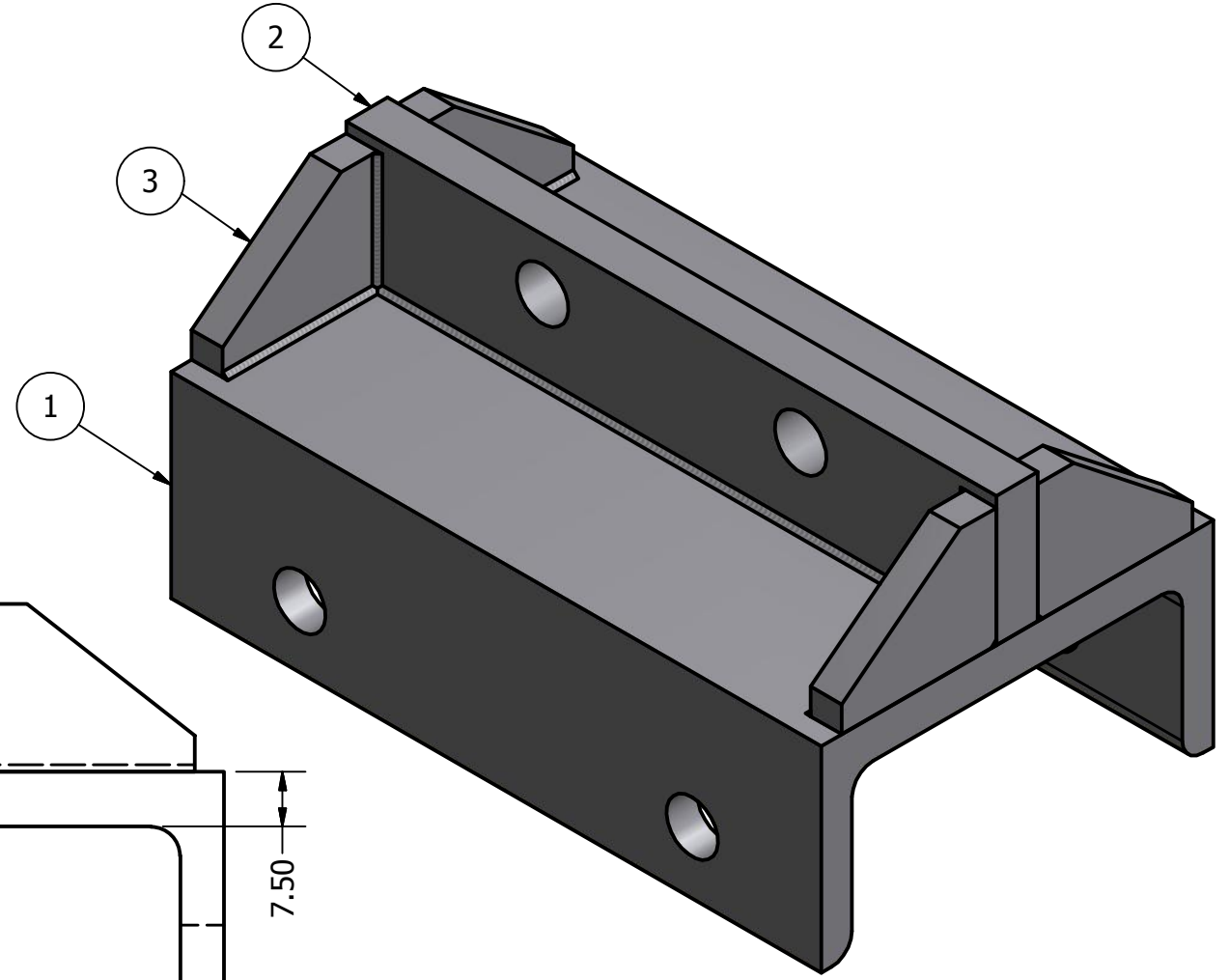

VIEW1  
SCALE 1 : 1

DRAWN swaters	4/15/2010	TITLE	
CHECKED		CASTER FRAME	
QA		SIZE B	DWG NO FIG 18-44
MFG		SCALE 1:1	REV
APPROVED		SHEET 1 OF 1	