

4

3

2

1

B

B

A

A

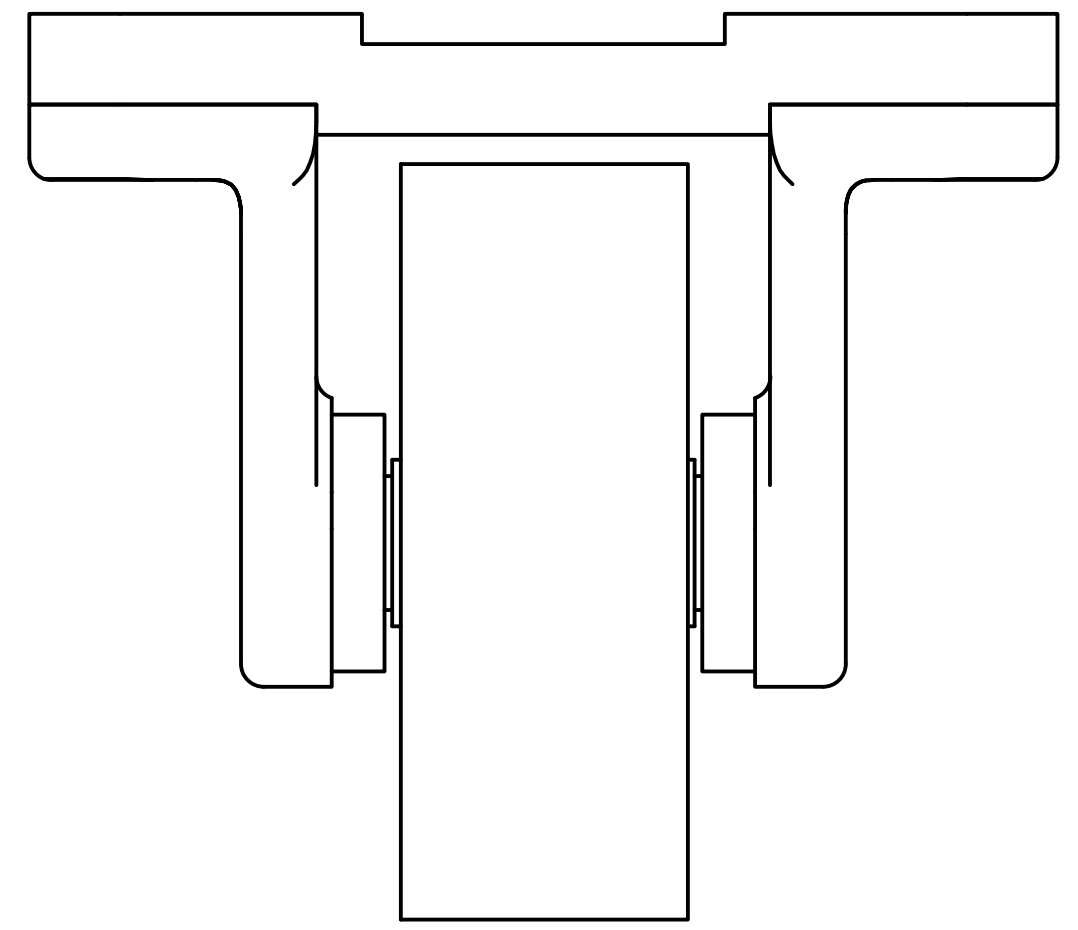

CASTER ASSEMBLY
SCALE 1 : 1

PARTS LIST			
ITEM	QTY	PART NUMBER	MATERIAL
1	1	TOP PLATE	MALLEABLE IRON
2	2	AXLE SUPPORT	MALLEABLE IRON
3	1	AXLE	SAE 1020
4	2	BUSHING	BRONZE
5	1	WHEEL	MALLEABLE IRON

DRAWN	swaters	1/26/2010		
CHECKED				
QA			TITLE	
MFG			CASTER ASSEMBLY	
APPROVED				
		SIZE	DWG NO	REV
		B	FIG 9-51	
		SCALE	1:1	SHEET 1 OF 7

TABLE	
Column 1	Column 2
FIT	BETWEEN PARTS
H8/f7	3 AND 4
H7/p6	2 AND 4
H8/f7	5 AND 3

FASTEN ASSEMBLY TO A 6mm STEEL PLATE BY
FOUR M 10 x 40mm LG HEX HD BOLT, NUT AND LOCK WASHER.
ROUNDS AND FILLETS R 3

PARTS LIST			
ITEM	QTY	PART NUMBER	DESCRIPTION
1	1	TOP PLATE	MALLEABLE IRON
2	2	AXLE SUPPORT	MALLEABLE IRON
3	1	AXLE	SAE 1020
4	2	BUSHING	BRONZE
5	1	WHEEL	MALLEABLE IRON

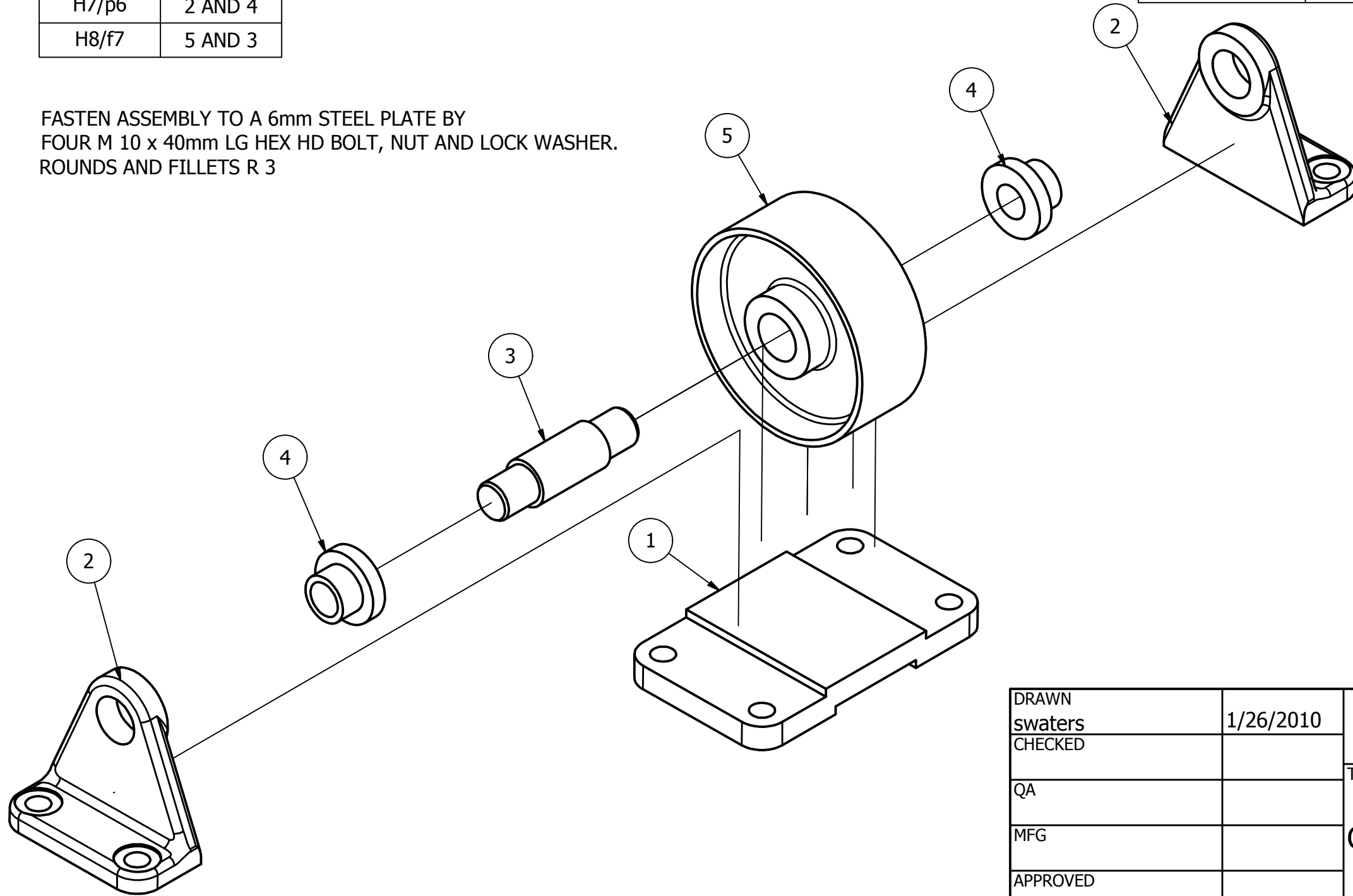

CASTER ASSEMBLY EXPLODED
SCALE 1 / 2

DRAWN swaters	1/26/2010	TITLE	
CHECKED		CASTER ASSEMBLY	
QA		SIZE B	DWG NO FIG 9-51
MFG		SCALE 1/2	REV
APPROVED		SHEET 2 OF 7	

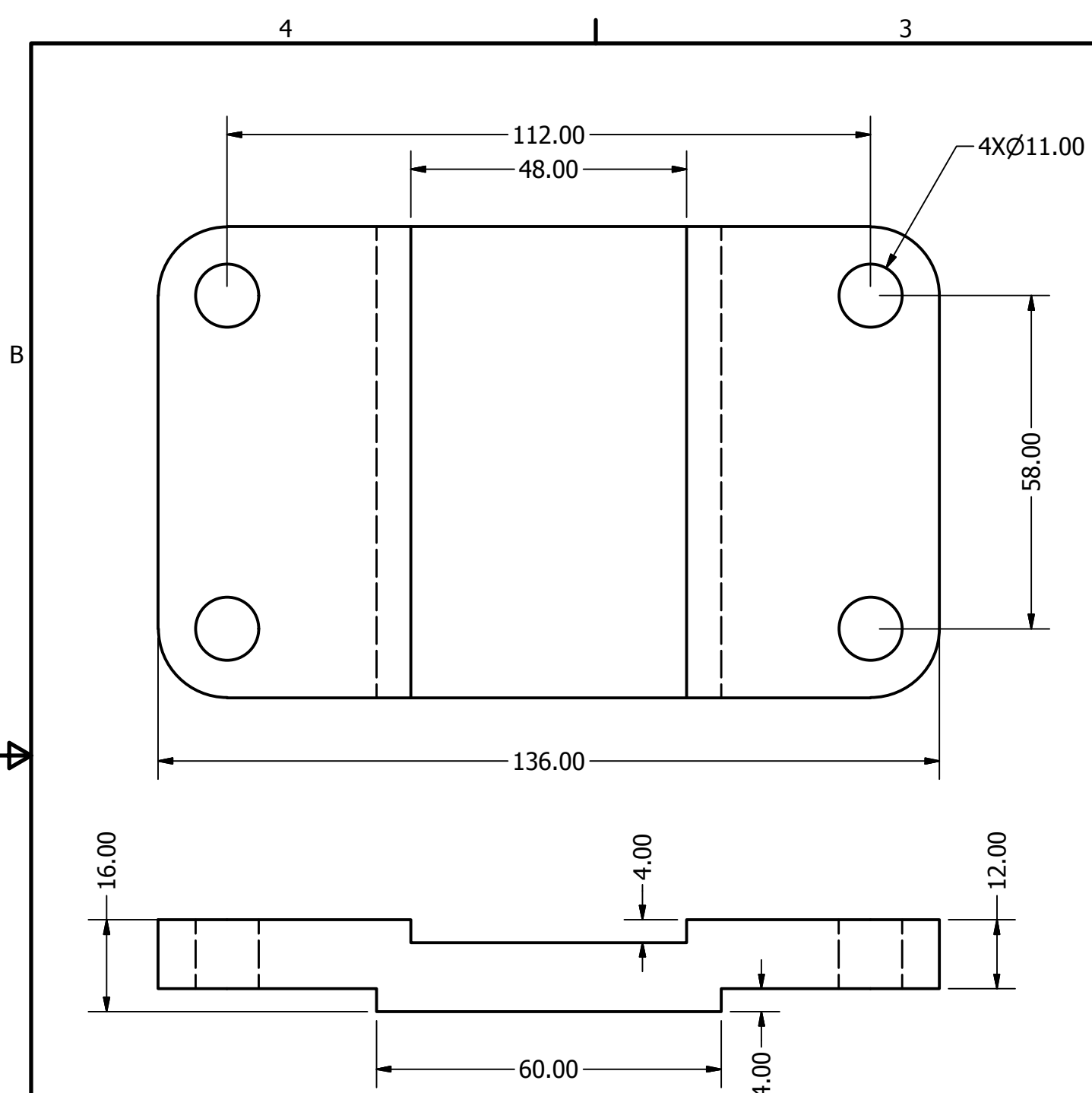

TOP PLATE
SCALE 1 : 1

PARTS LIST			
ITEM	QTY	PART NUMBER	MATERIAL
1	1	TOP PLATE	MALLEABLE IRON

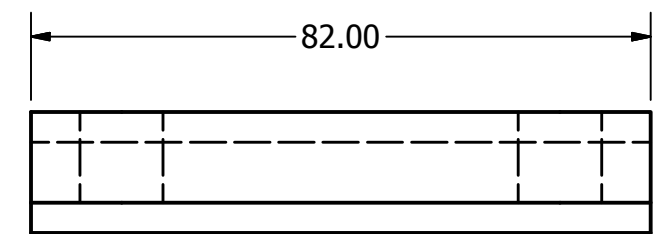
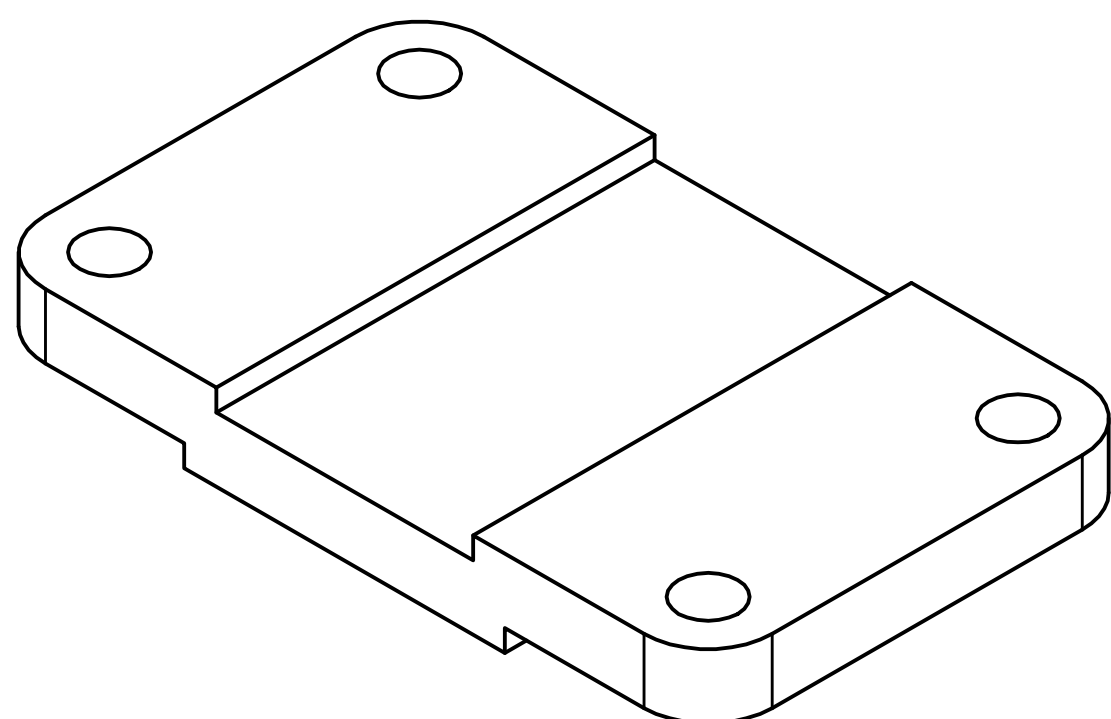

DRAWN swaters	1/26/2010	TITLE CASTER ASSEMBLY		
CHECKED				
QA				
MFG				
APPROVED		SIZE B	DWG NO FIG 9-51	REV
		SCALE 1:1	SHEET 3 OF 7	

PARTS LIST			
ITEM	QTY	PART NUMBER	MATERIAL
3	1	AXLE	SAE 1020

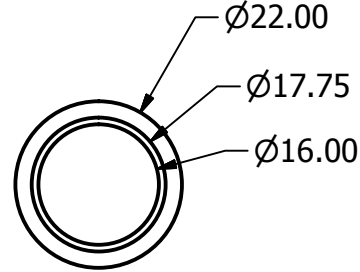
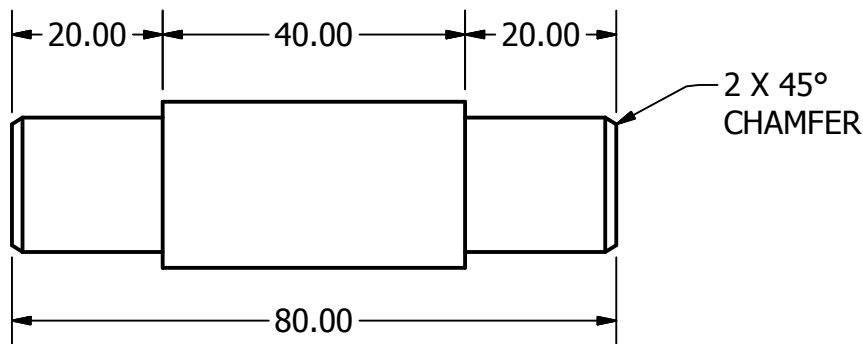
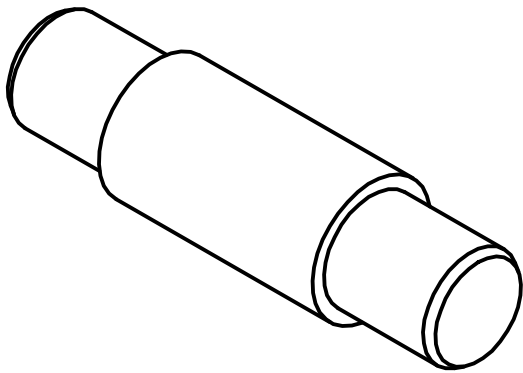

AXLE
SCALE 1 : 1

DRAWN	swaters	1/26/2010	TITLE	
CHECKED			CASTER ASSEMBLY	
QA			SIZE	DWG NO
MFG			B	FIG 9-51
APPROVED			SCALE	REV
			1:1	
			SHEET 4 OF 7	

PARTS LIST			
ITEM	QTY	PART NUMBER	MATERIAL
4	2	BUSHING	BRONZE

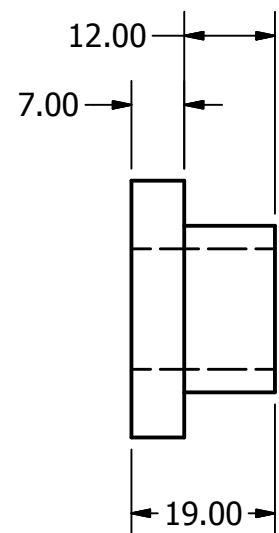
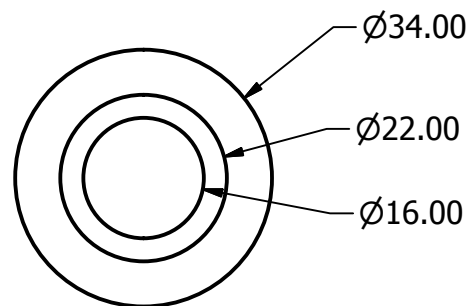
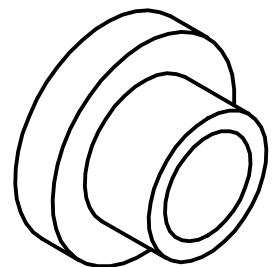

BUSHING
SCALE 1 : 1

DRAWN	swaters	1/26/2010		
CHECKED				
QA			TITLE	
MFG			CASTER ASSEMBLY	
APPROVED				
		SIZE	DWG NO	REV
		B	FIG 9-51	
		SCALE	1:1	SHEET 5 OF 7

PARTS LIST			
ITEM	QTY	PART NUMBER	MATERIAL
2	2	AXLE SUPPORT	MALLEABLE IRON

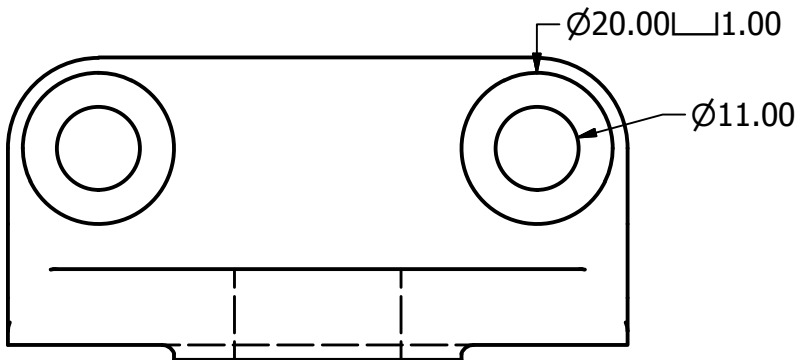

ROUNDS AND FILLETS R 3

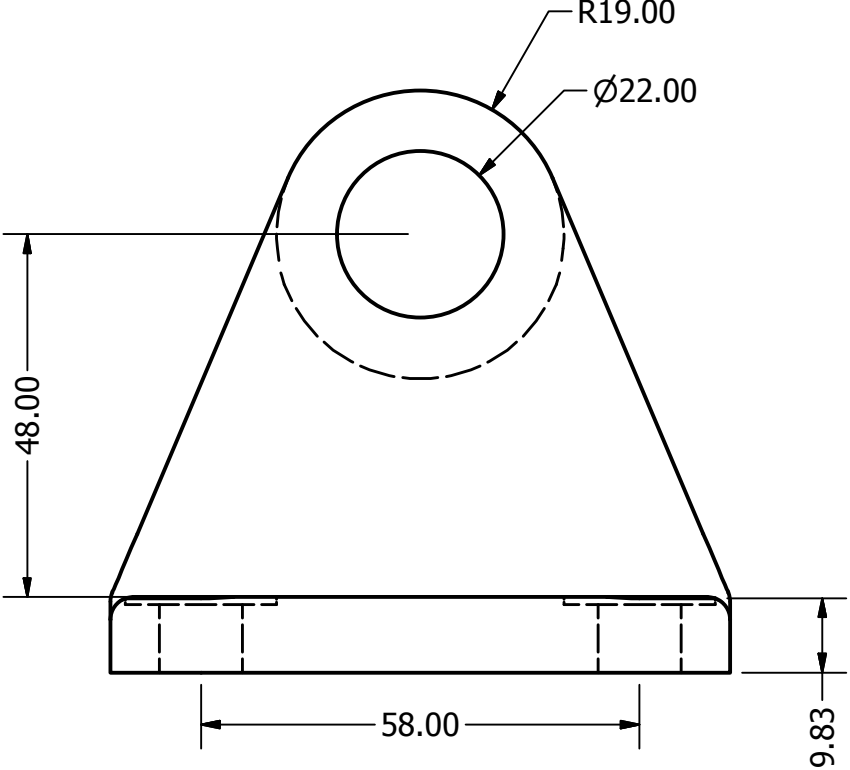
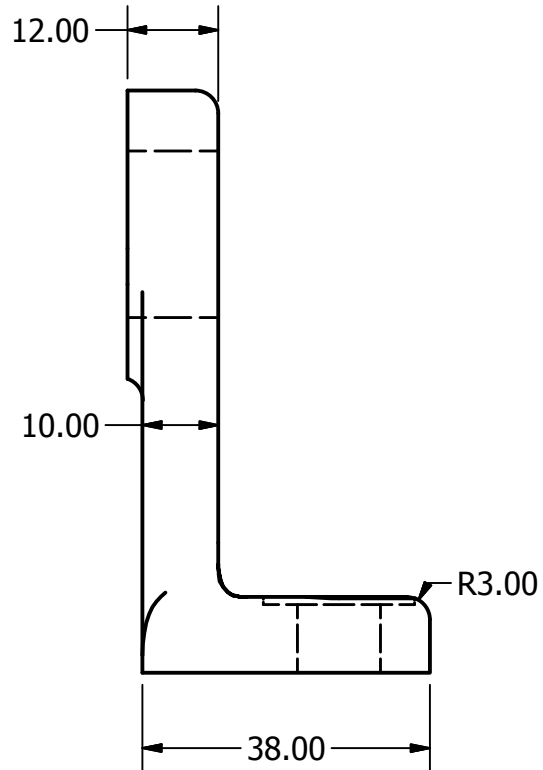
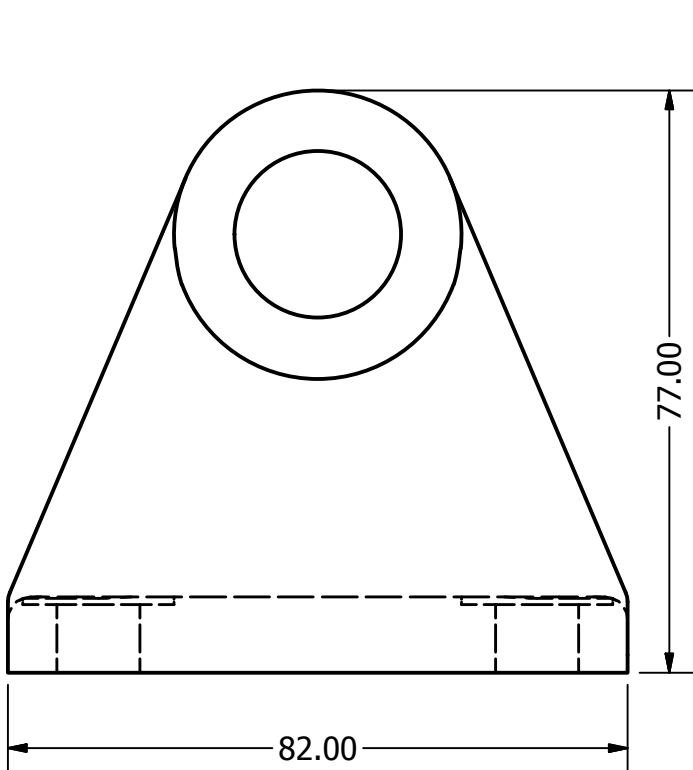

AXLE SUPPORT
SCALE 1 : 1

DRAWN swaters	1/26/2010	TITLE		
CHECKED		CASTER ASSEMBLY		
QA		SIZE	DWG NO	REV
MFG		B	FIG 9-51	
APPROVED		SCALE	1:1	SHEET 6 OF 7

PARTS LIST			
ITEM	QTY	PART NUMBER	MATERIAL
5	1	WHEEL	MALLEABLE IRON

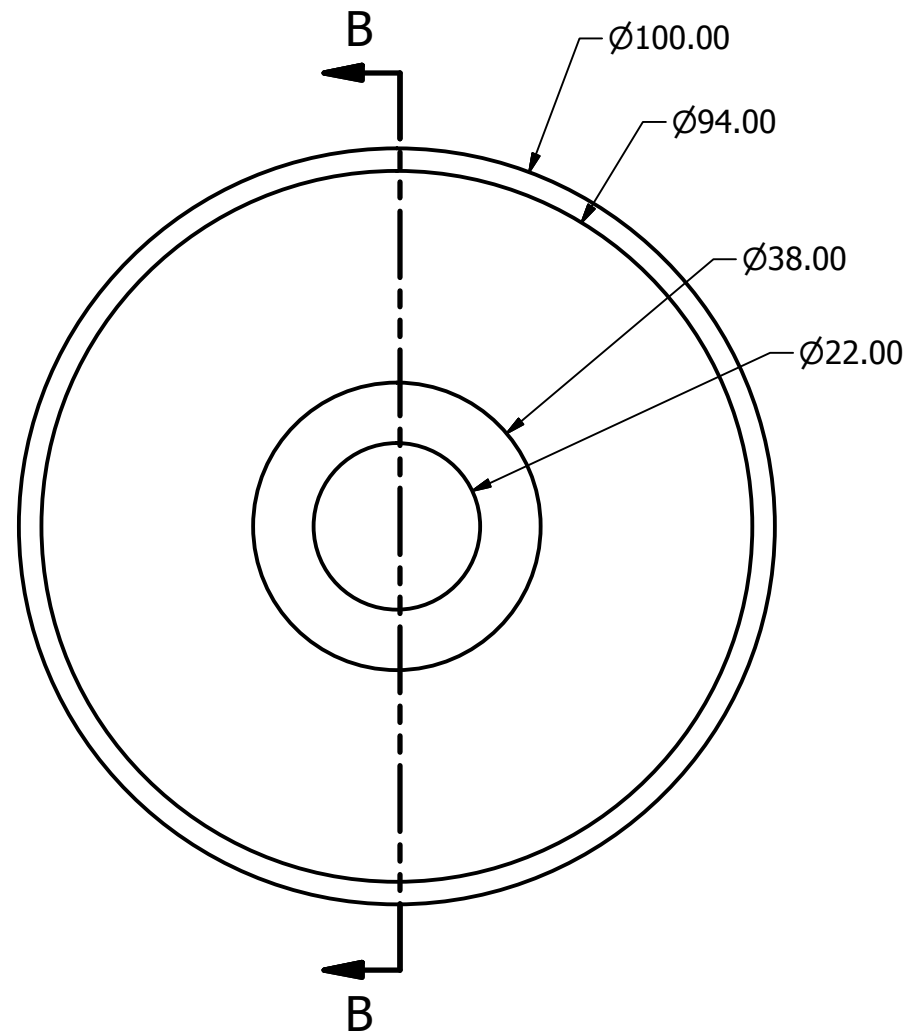

WHEEL
SCALE 1 : 1

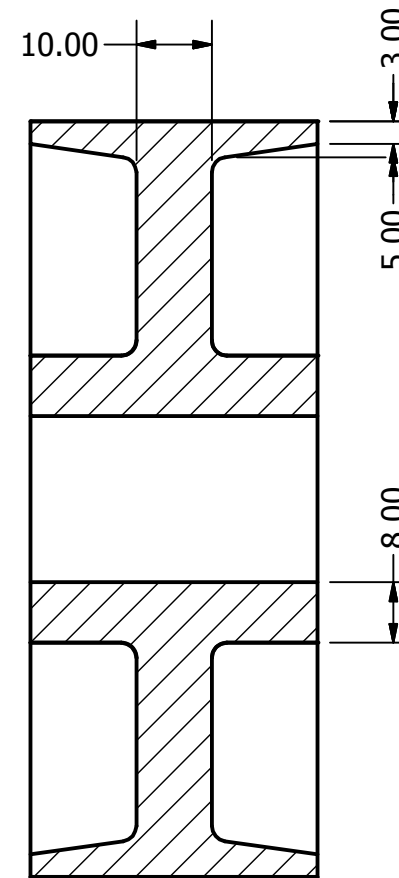
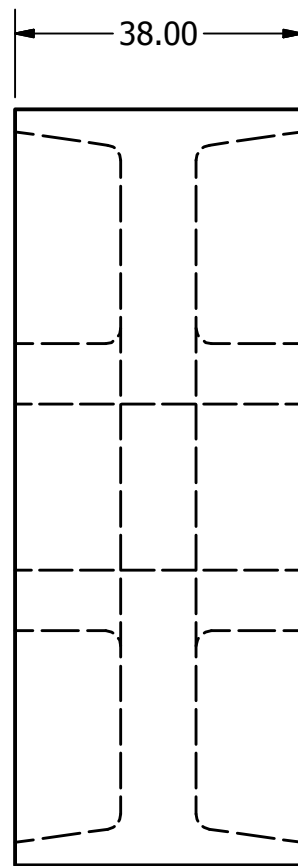

SECTION B-B
SCALE 1 : 1

DRAWN swaters	1/26/2010	TITLE CASTER ASSEMBLY			
CHECKED					
QA		SIZE B			
MFG					
APPROVED		DWG NO FIG 9-51		REV	
		SCALE 1:1	SHEET 7 OF 7		