

DRAWN		DDGT 120		
PATRICK MURPHY	2/19/2009	TITLE		
CHECKED		FIG 14-83 TROLLEY		
QA		SIZE	DWG NO	REV
MFG		B	ASSEMBLED TROLLEY-1	
APPROVED		SCALE	SHEET 1 OF 8	

PARTS LIST			
ITEM	QTY	PART NUMBER	SHEET
1	2	ASSEMBLY SIDE	3
2	1	PT3 AXLE	6
3	1	PT4 HANGER	7
4	1	S200 X 34 BEAM	
5	2	COTTER PIN Ø6 X 40 LG	
6	12	ADJUSTING WASHER 26 ID X 440 D X 4 THK	

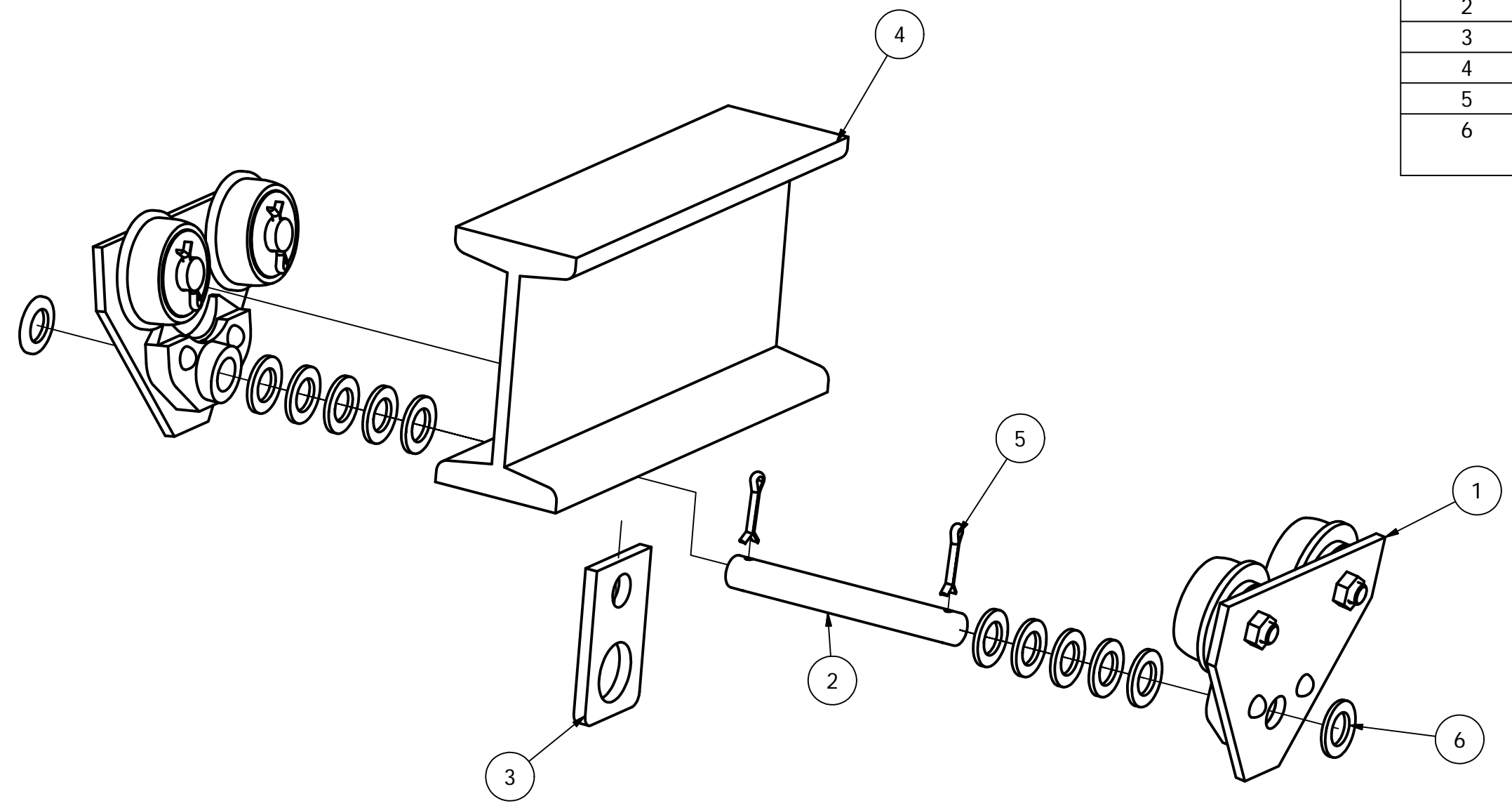

DRAWN PATRICK MURPHY	2/19/2009	DDGT 120	
CHECKED		TITLE	
QA		FIG 14-83 TROLLEY	
MFG		SIZE B	DWG NO ASSEMBLED TROLLEY-1
APPROVED		SCALE	REV
			SHEET 2 OF 8

4

3

2

1

PARTS LIST			
ITEM	QTY	PART NUMBER	SHEET
1	2	ASSEMBLY WHEEL	4
2	1	PT1 SIDE PLATE	5
3	1	PT2 GUIDE	6
4	2	LOCKNUT M16 X 2 PREVAILING TORQUE INSERT TYPE	-
5	2	RIVET, BUTTON HEAD Ø10 X 60 LG	-

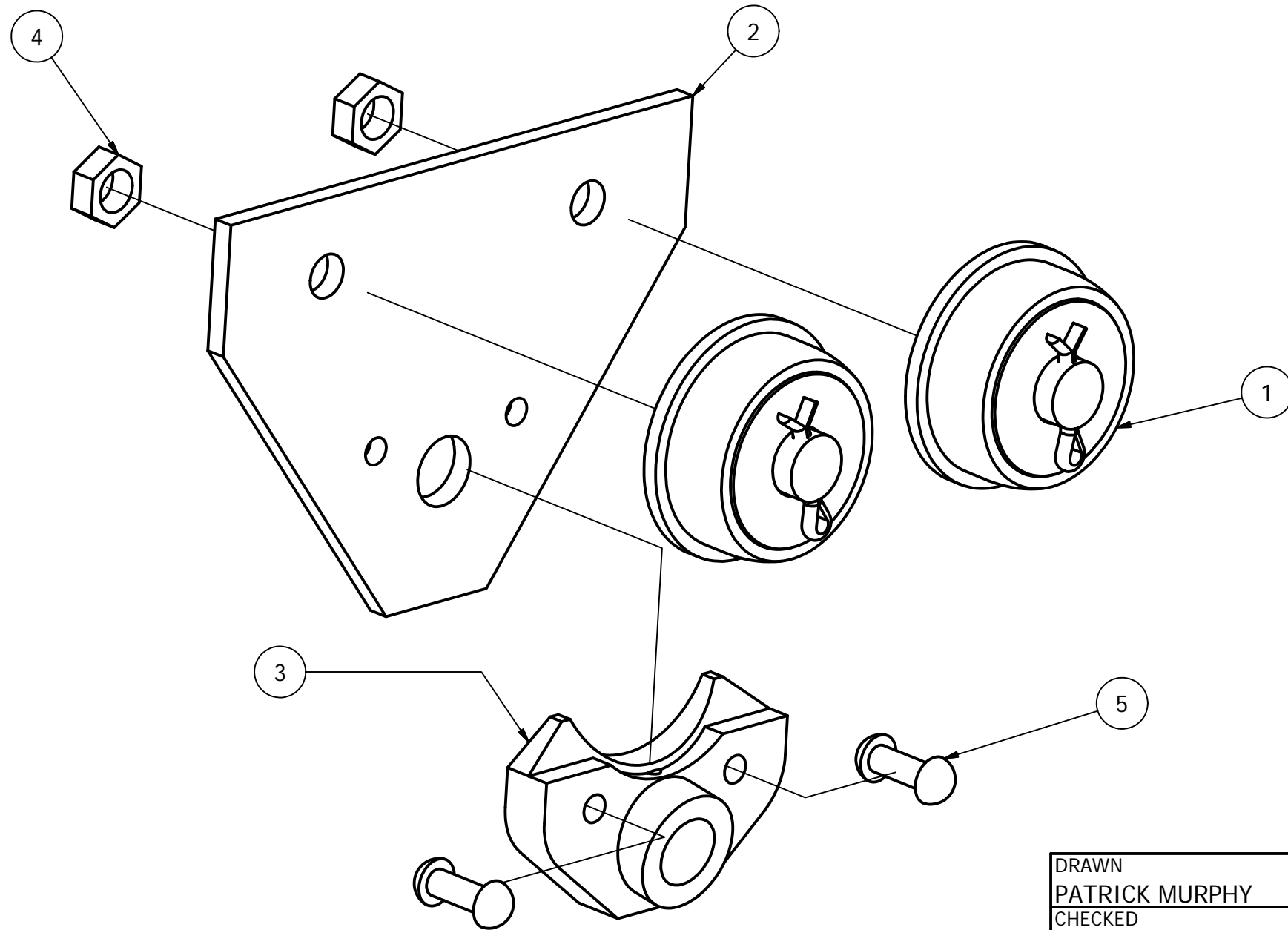

EXPLODED SIDE  
SCALE 1 / 2

DRAWN PATRICK MURPHY	2/19/2009	DDGT 120	
CHECKED		TITLE	
QA		FIG 14-83 TROLLEY	
MFG		SIZE B	DWG NO ASSEMBLED TROLLEY-1
APPROVED		SCALE	REV
			SHEET 3 OF 8

4

3

2

1

4

3

2

1

PARTS LIST			
ITEM	QTY	PART NUMBER	SHEET
1	11	PT5 ROLLER BEARING	7
2	1	PT6 WHEEL	8
3	1	PT7 AXLE	8
4	1	WASHER 26 ID X 65 OD X 3 THK	
5	1	COTTER PIN Ø6 X 40 LG	

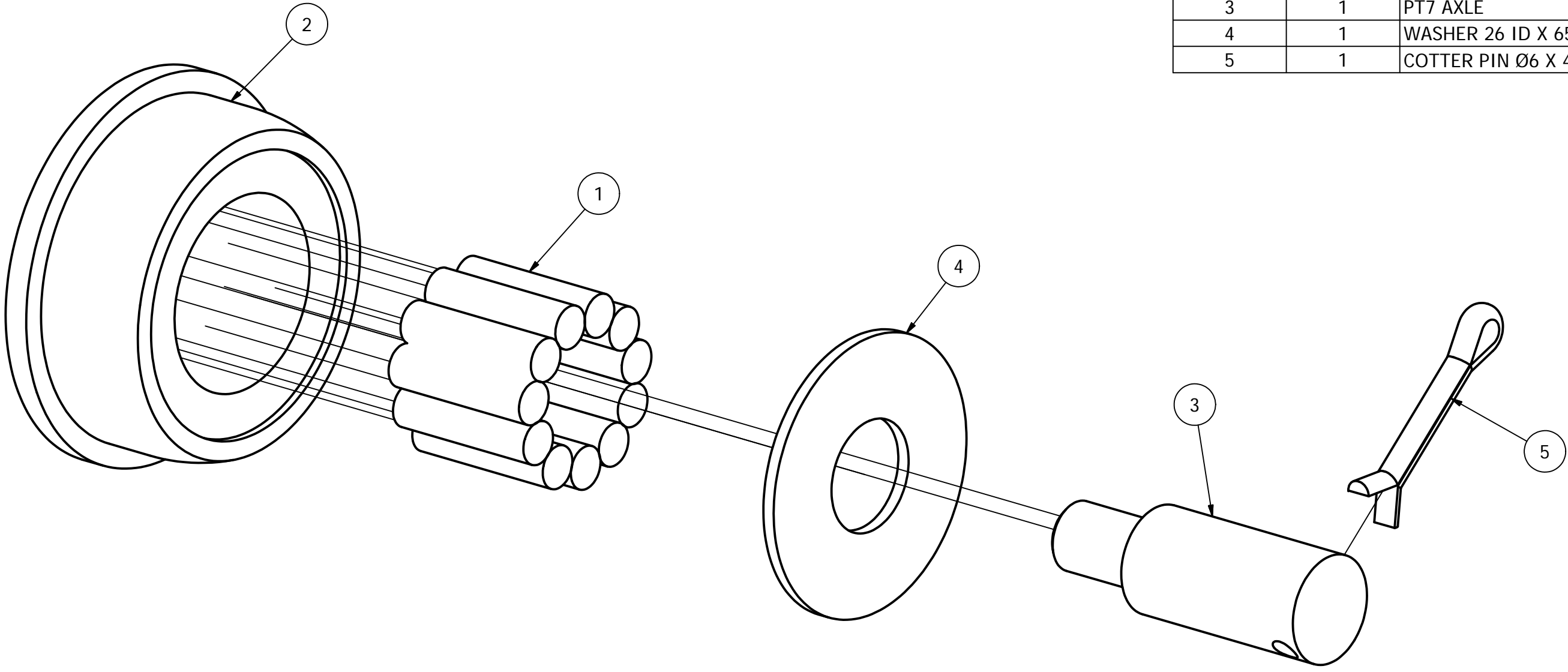

EXPLODED WHEEL  
SCALE 1 : 1

DRAWN	PATRICK MURPHY	2/19/2009	DDGT 120	
CHECKED			TITLE	
QA			FIG 14-83 TROLLEY	
MFG			SIZE	DWG NO
APPROVED			B	ASSEMBLED TROLLEY-1
			SCALE	REV
				SHEET 4 OF 8

4

3

2

1

PARTS LIST			
ITEM	QTY	PART NUMBER	MATERIAL
1	1	PT1 SIDE PLATE	MST

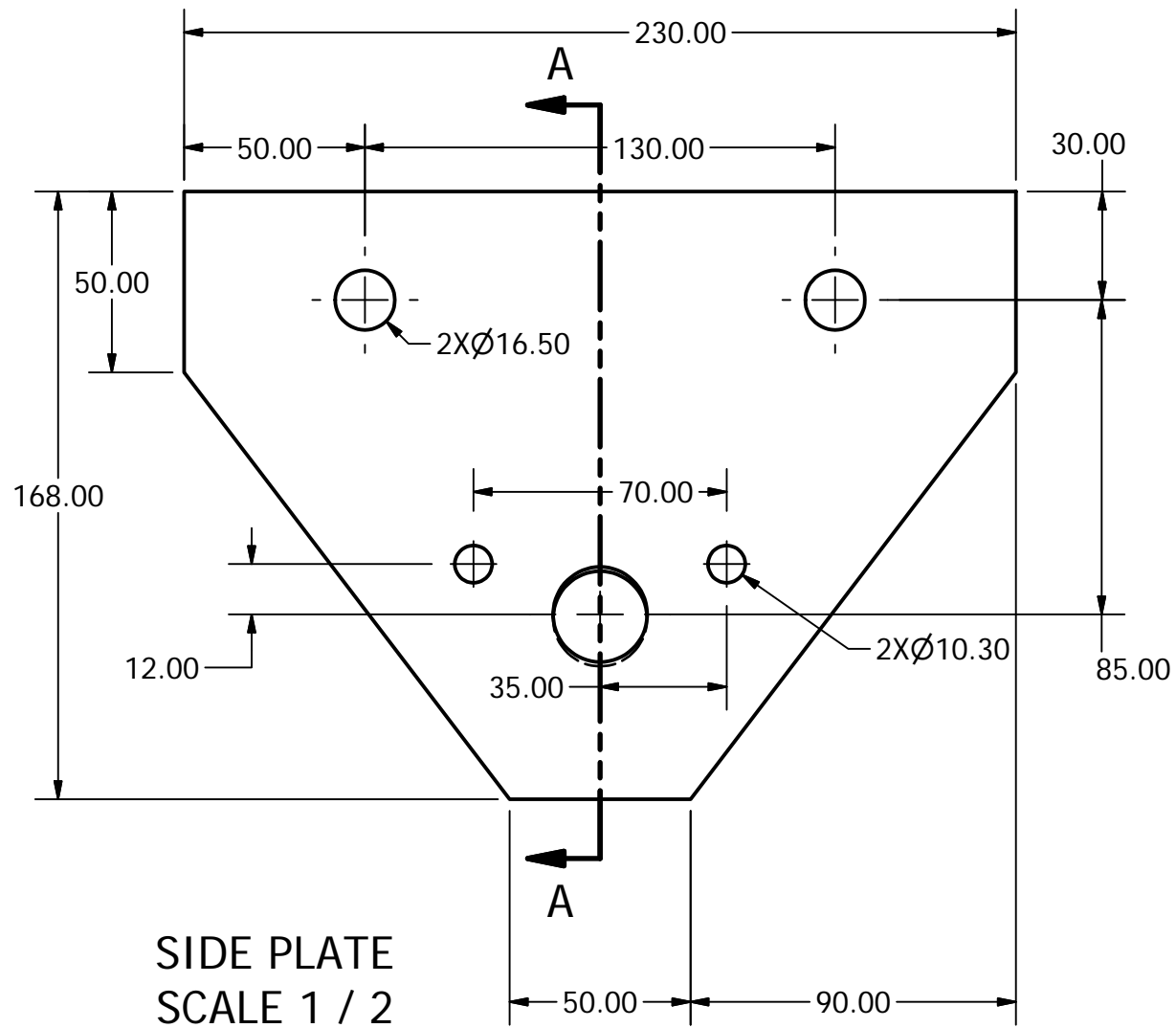

SIDE PLATE  
SCALE 1 / 2

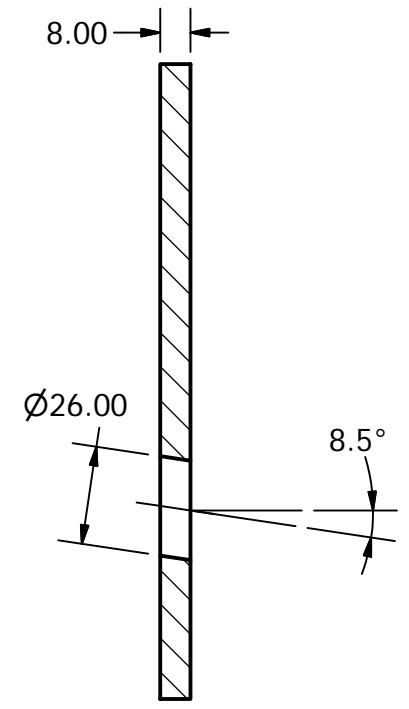

SECTION A-A  
SCALE 1 / 2

DRAWN PATRICK MURPHY	2/19/2009	DDGT 120		
CHECKED		TITLE		
QA		FIG 14-83 TROLLEY		
MFG		SIZE B	DWG NO	REV
APPROVED		ASSEMBLED TROLLEY-1		
		SCALE	SHEET 5 OF 8	

PARTS LIST			
ITEM	QTY	PART NUMBER	MATERIAL
1	1	PT2 GUIDE	C1
2	1	PT3 AXLE	CRS

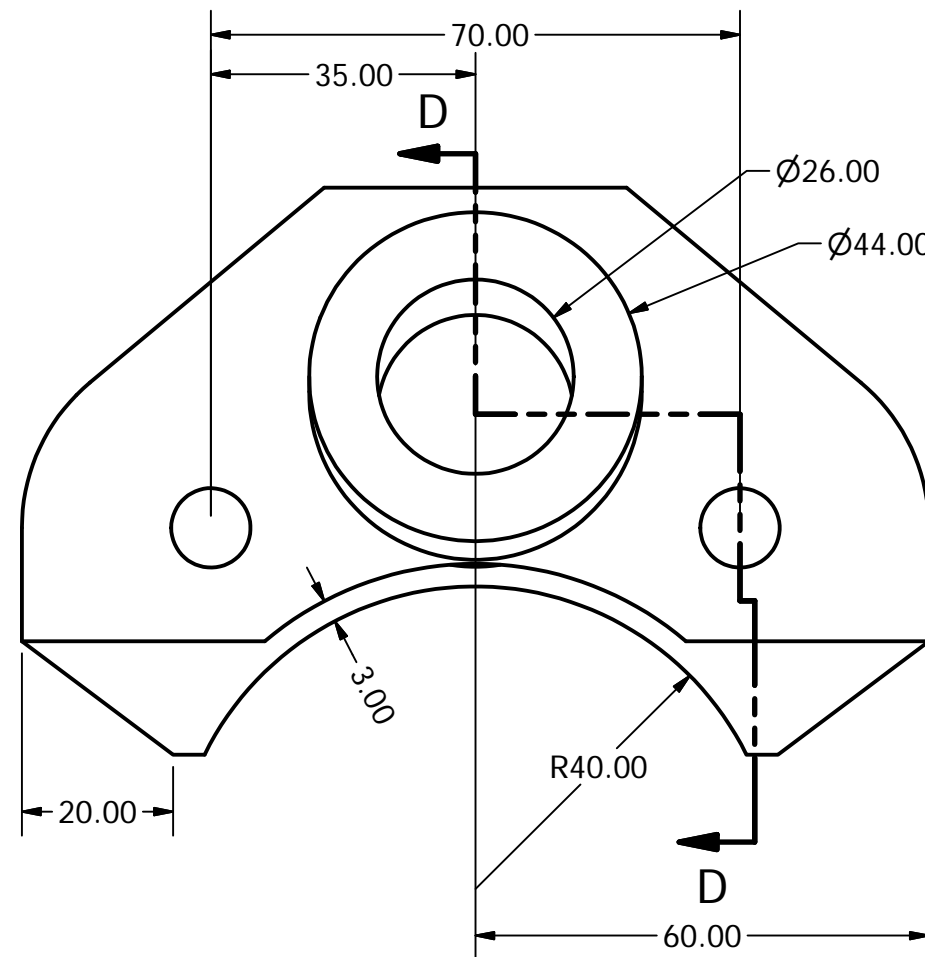
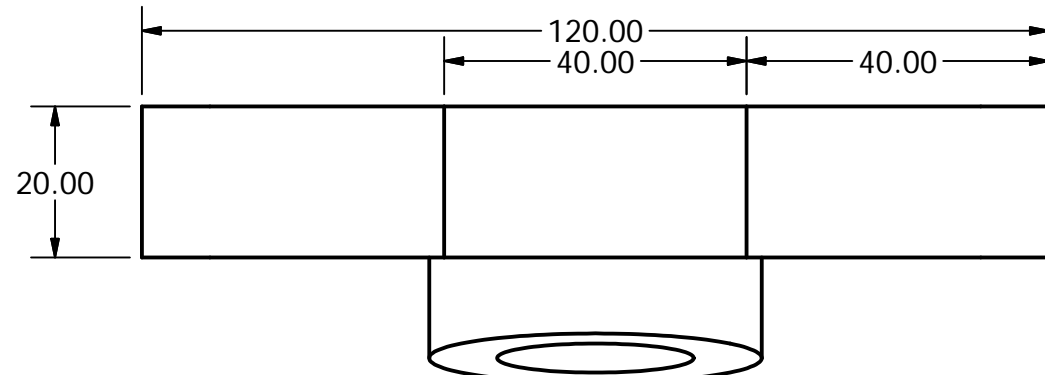

PART 2 - GUIDE  
SCALE 1 : 1

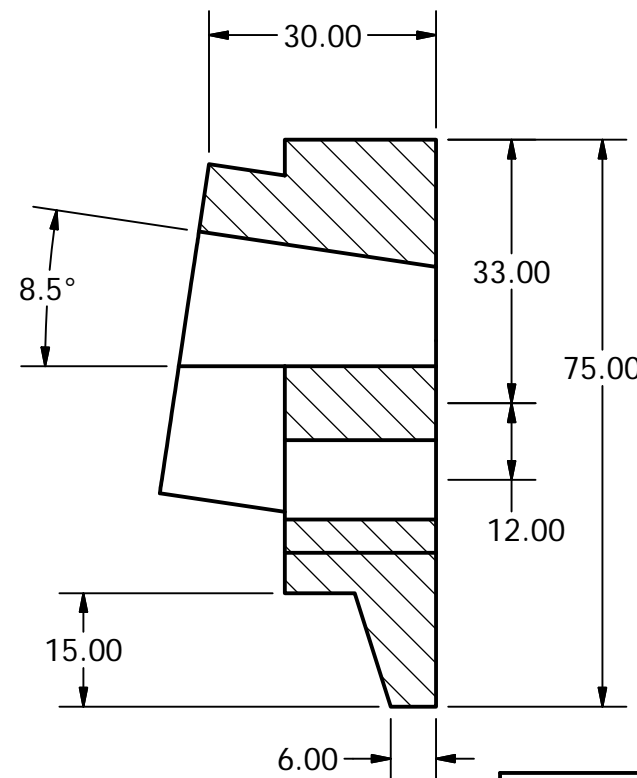

SECTION D-D  
SCALE 1 : 1

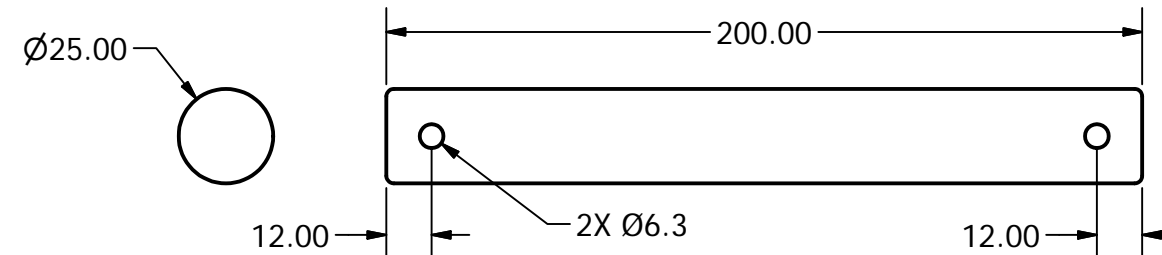

PT3 AXLE  
SCALE 1 / 2

DRAWN PATRICK MURPHY	2/19/2009	DDGT 120	
CHECKED		TITLE	
QA		FIG 14-83 TROLLEY	
MFG		SIZE B	DWG NO ASSEMBLED TROLLEY-1
APPROVED		SCALE	REV
			SHEET 6 OF 8

PARTS LIST			
ITEM	QTY	PART NUMBER	MATERIAL
1	1	PT4 HANGER	MST
2	1	PT5 ROLLER BEARING	CRS

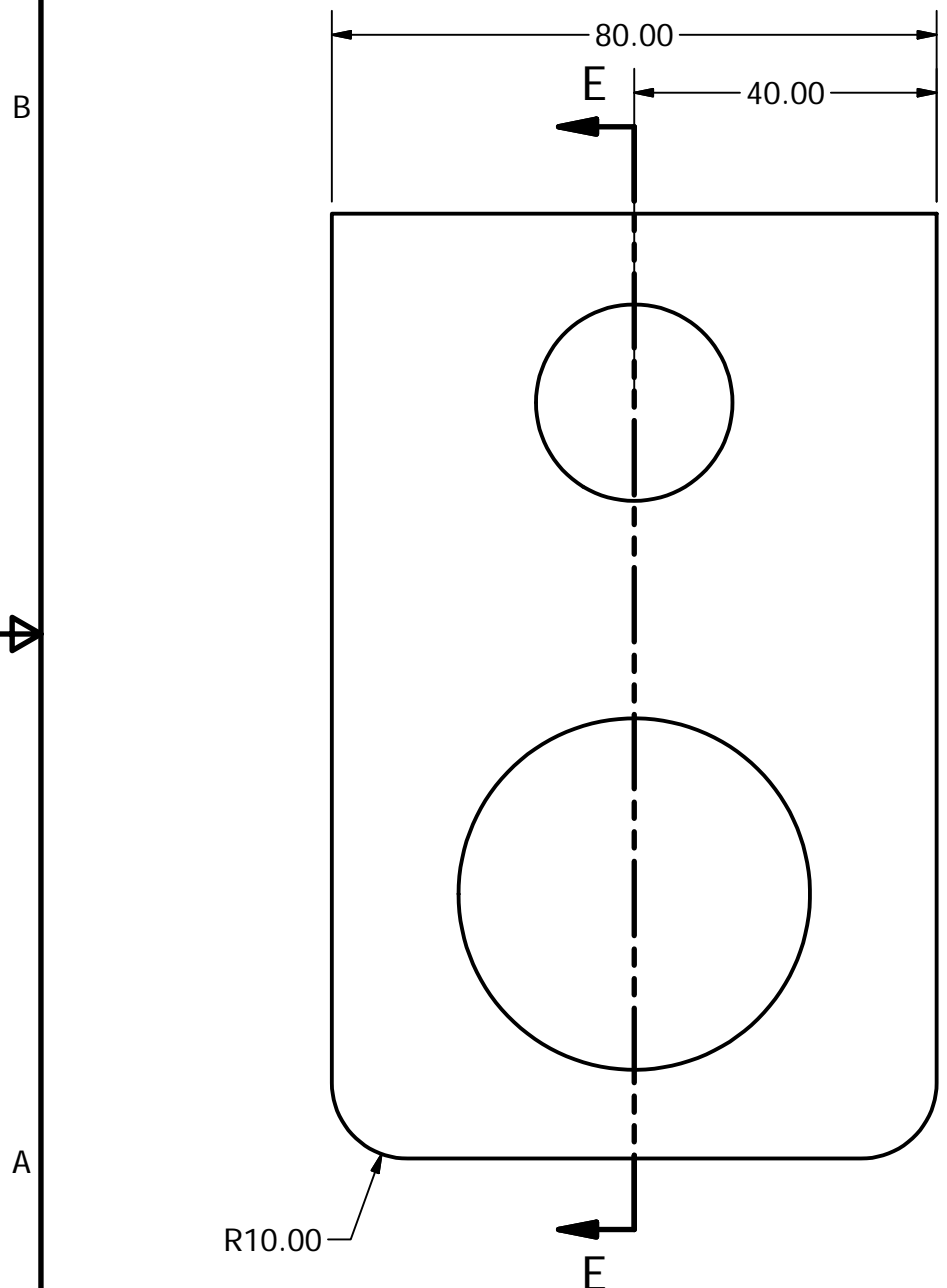

PT4 HANGER  
SCALE 1 : 1

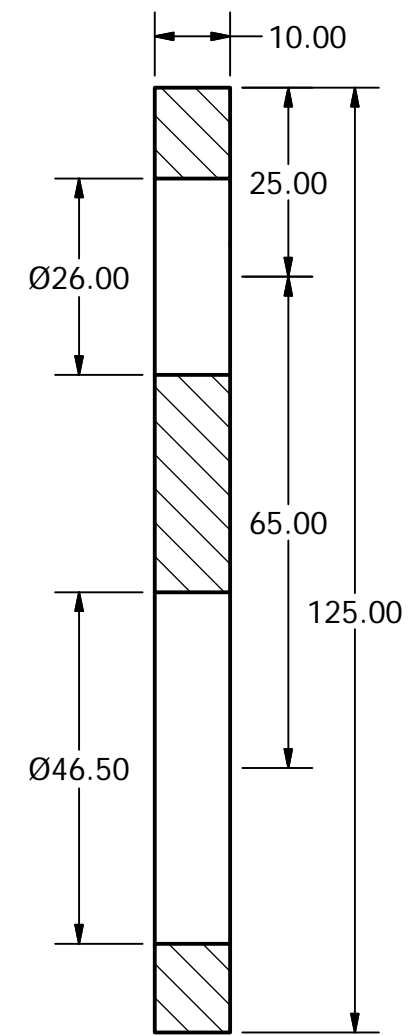

SECTION E-E  
SCALE 1 : 1

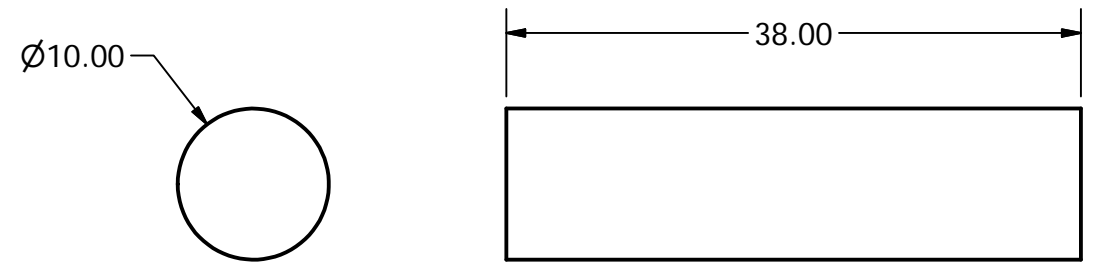

PT5 ROLLER BEARING  
SCALE 2 : 1

DRAWN PATRICK MURPHY	2/19/2009	DDGT 120		
CHECKED		TITLE		
QA		FIG 14-83 TROLLEY		
MFG				
APPROVED				
		SIZE B	DWG NO ASSEMBLED TROLLEY-1	REV
		SCALE	SHEET 7 OF 8	

PARTS LIST			
ITEM	QTY	PART NUMBER	MATERIAL
1	1	PT6 WHEEL	C1
2	1	PT7 AXLE	CRS

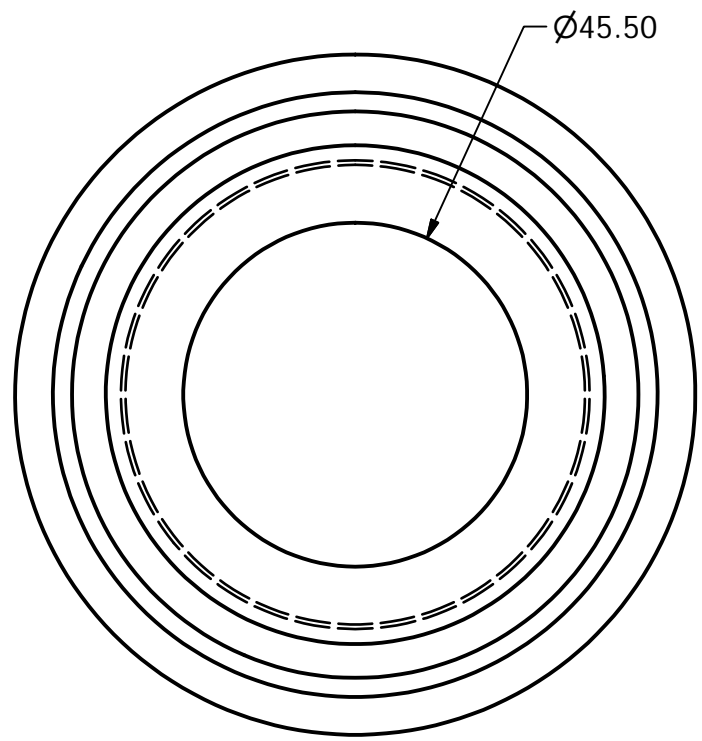

PT6 WHEEL  
SCALE 1 : 1

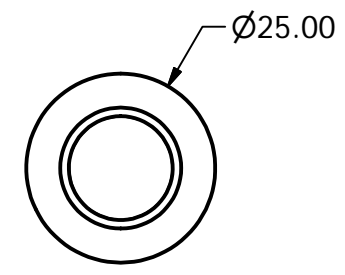
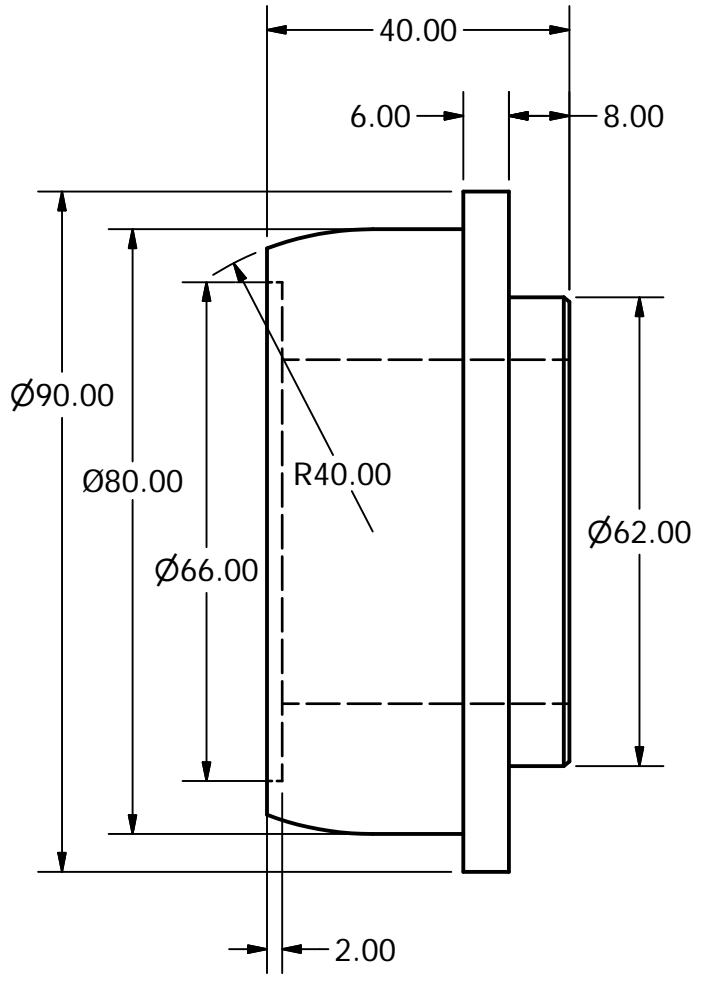

PT7 AXLE  
SCALE 1 : 1

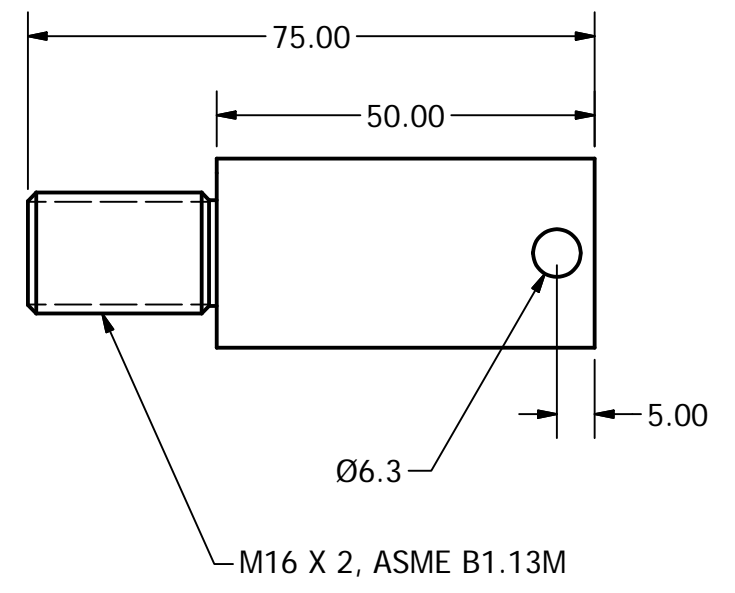

DRAWN	PATRICK MURPHY	2/19/2009	DDGT 120	
CHECKED			TITLE	
QA			FIG 14-83 TROLLEY	
MFG			SIZE	DWG NO
APPROVED			B	ASSEMBLED TROLLEY-1
			SCALE	REV
				SHEET 8 OF 8