

FIT	BETWEEN PARTS
H8/f7	4 AND 5
H7/p6	3 AND 5
H8/f7	2 AND 4

PARTS LIST			
ITEM	QTY	PART NUMBER	MATERIAL
1	1	TOP PLATE	MALLEABLE IRON
2	1	WHEEL	MALLEABLE IRON
3	2	AXLE SUPPORT	MALLEABLE IRON
4	1	AXLE	SAE 1020
5	2	BUSHING	BRONZE

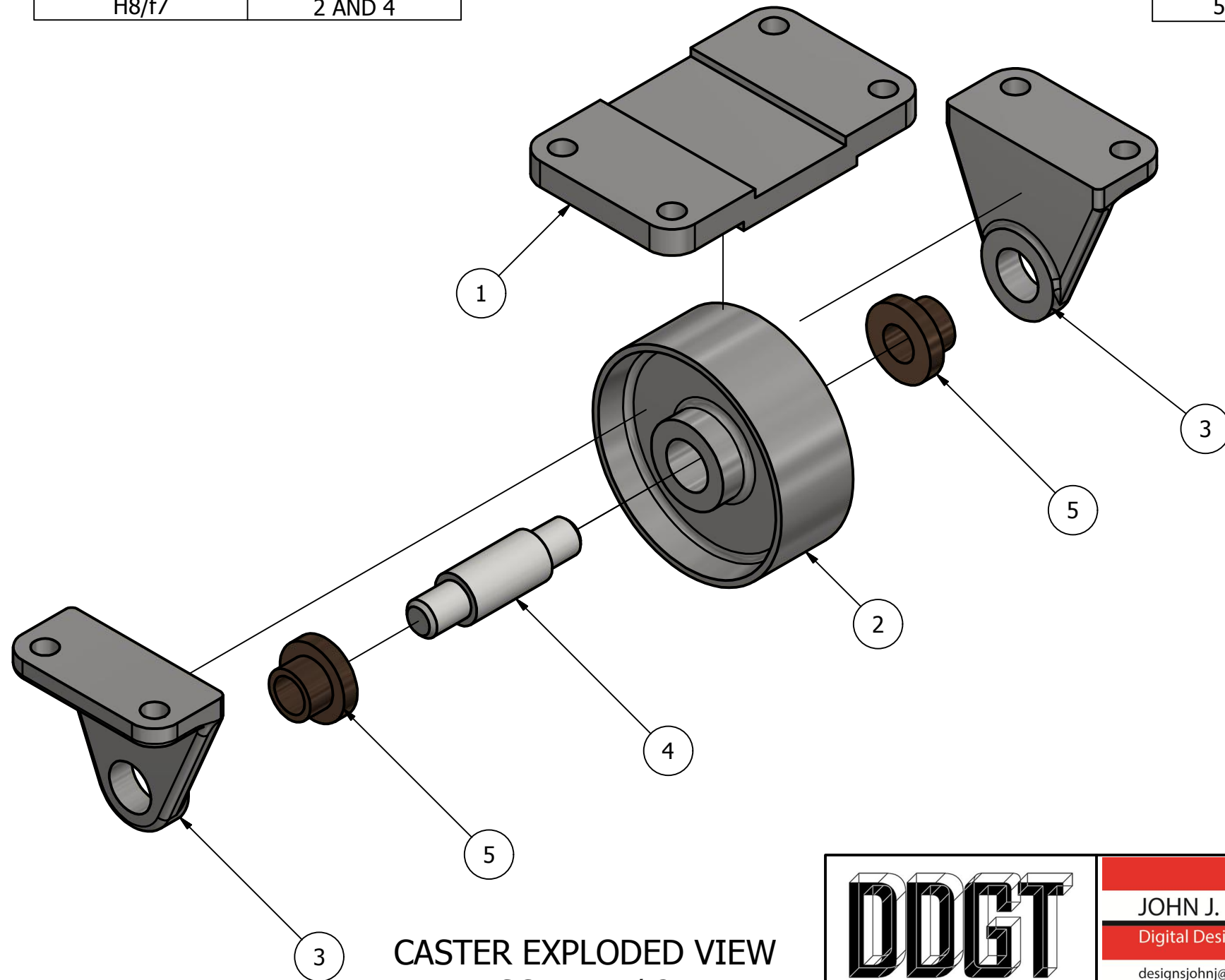

METRIC

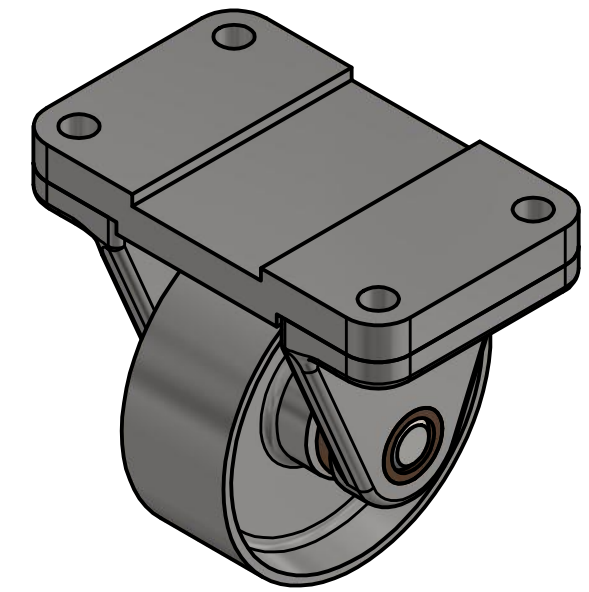

CASTER ASSEMBLY
SCALE 1 / 2

CASTER EXPLODED VIEW
SCALE 1 / 2

DDGT
DIGITAL DESIGN
GRAPHICS
TECHNOLOGY
WWW.DDGT.NET

JOHN J. BOLLA
Digital Designer
designsjohnj@gmail.com
ddgt.net/StudentPages/jbolla
Specializing in CAD Design
and Visualization

TOLERANCES UNLESS SPECIFIED
MILLIMETERS:
WHOLE NUMBER = ± .5
X = ± .25
XX = ± .12
ANGLES ± 1 DEGREE
SURFACES 32 ✓

COURSE:	DDGT 120
INVENTOR DRAWING NAME:	CASTER
FIG #:	9-51
DRAFTER:	J. BOLLA
DATE:	11/9/2015
SCALE:	AS NOTED
PAGE #:	1 OF 2

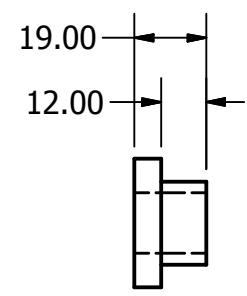
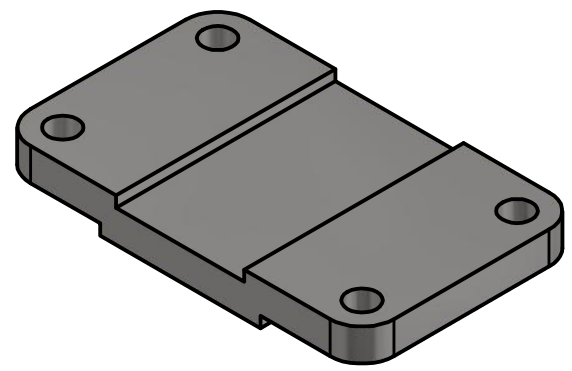
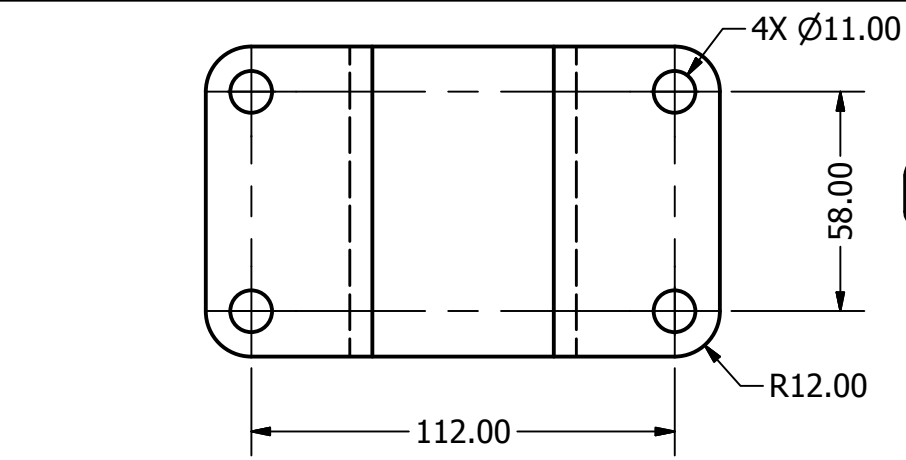

BUSHING
SCALE 1 / 2

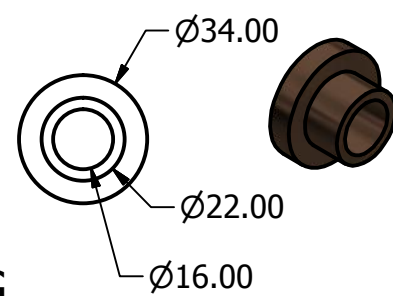

PARTS LIST		
ITEM	QTY	PART NUMBER
1	1	TOP PLATE
4	1	AXLE
2	1	WHEEL
3	2	AXLE SUPPORT
5	2	BUSHING

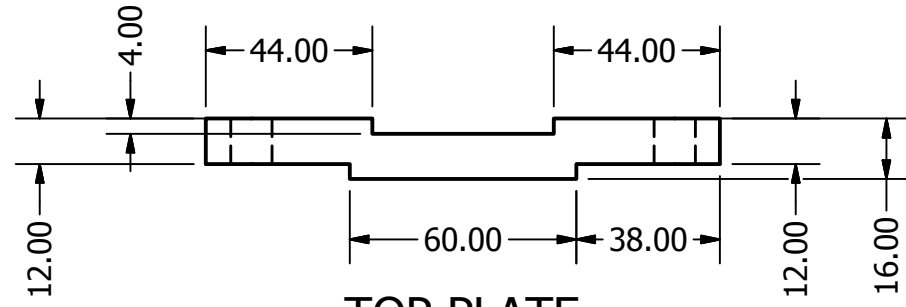

TOP PLATE
SCALE 1 / 2

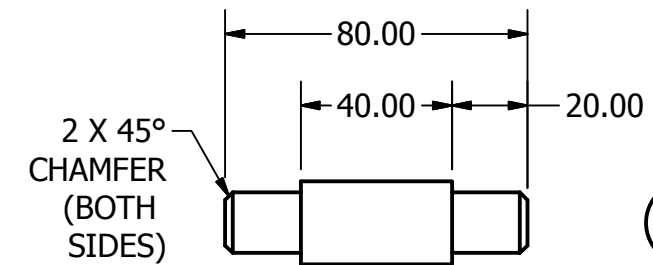

AXLE
SCALE 1 / 2

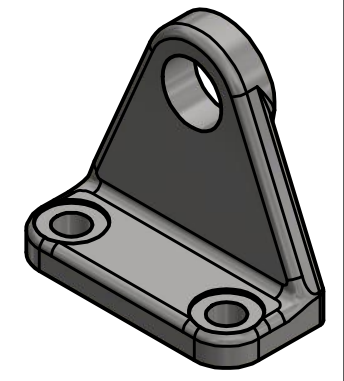
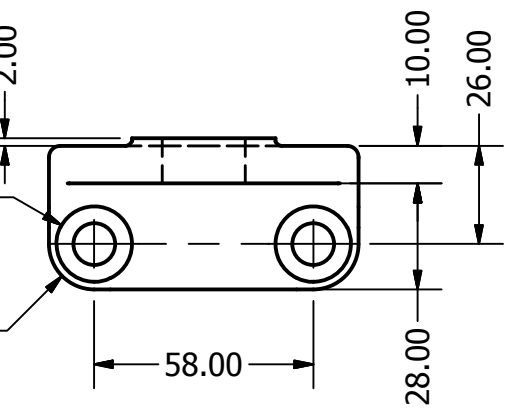
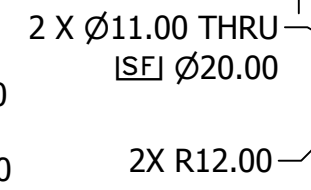
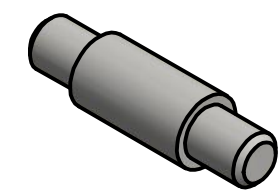
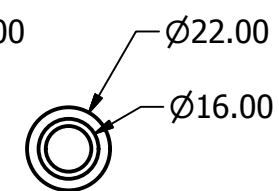

AXLE SUPPORT
SCALE 1 / 2

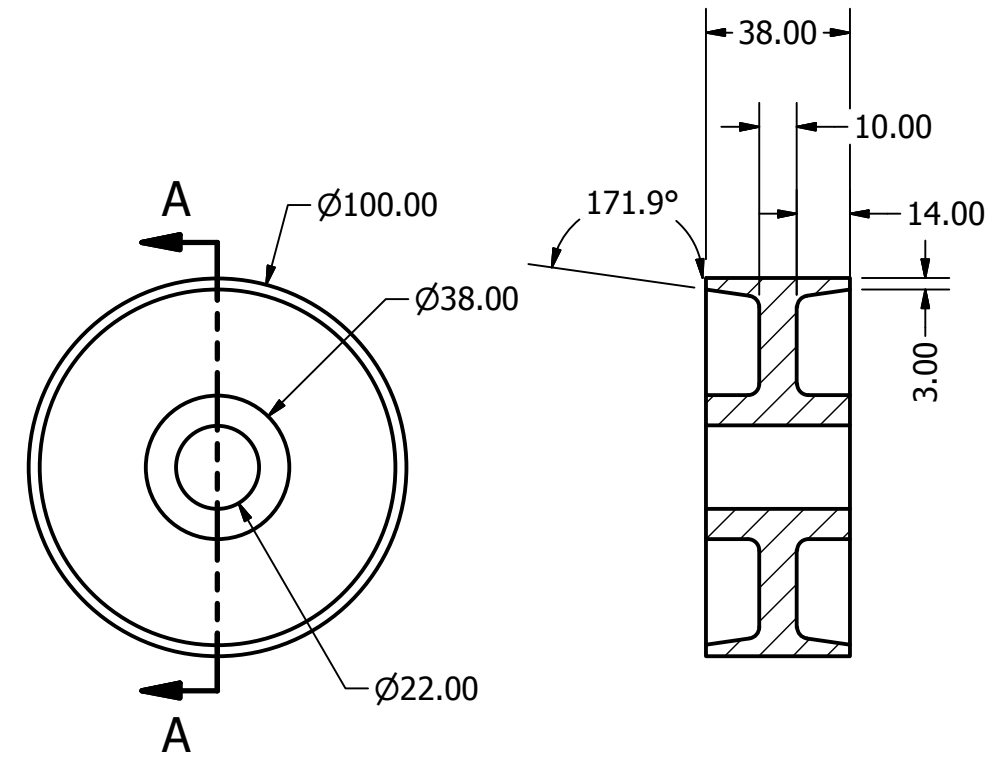

WHEEL
SCALE 1 / 2

SECTION A-A
SCALE 1 / 2

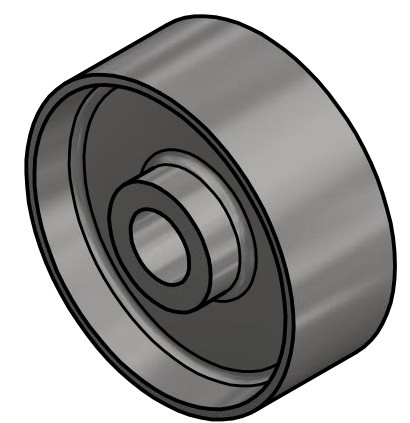

METRIC

ROUNDS AND FILLETS R3

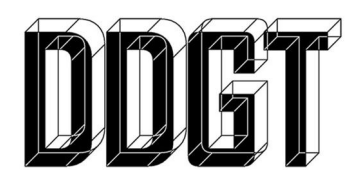
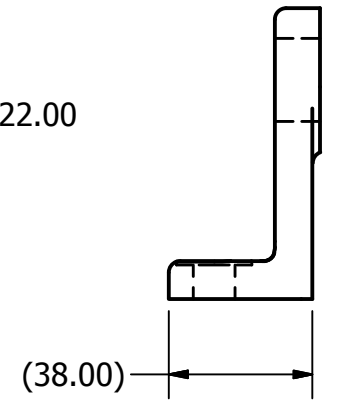
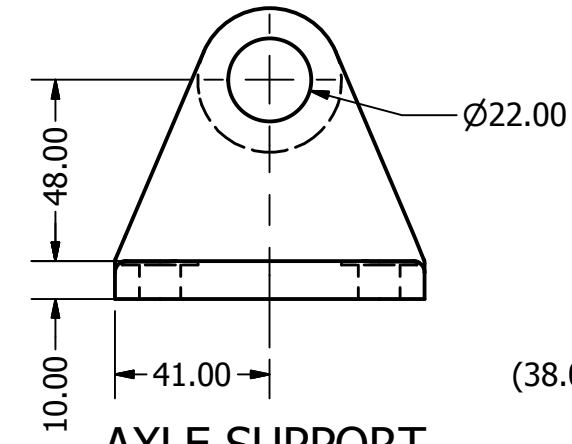

DIGITAL DESIGN
GRAPHICS
TECHNOLOGY

WWW.DDGT.NET

JOHN J. BOLLA
Digital Designer

designsjohnj@gmail.com
ddgt.net/StudentPages/jbolla

Specializing in CAD Design
and Visualization

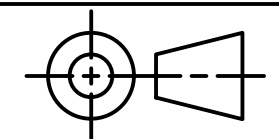

TOLERANCES UNLESS SPECIFIED
MILLIMETERS:
WHOLE NUMBER = ± .5
X = ± .25
XX = ± .12

ANGLES ± 1 DEGREE

SURFACES 32 ✓

COURSE: DDGT 120

INVENTOR DRAWING NAME:

CASTER

FIG #: 9-51

DRAFTER: J. BOLLA

DATE: 11/9/2015

SCALE: AS NOTED

PAGE #: 2 OF 2