

PARTS LIST				
ITEM	QTY	PART NUMBER	MATERIAL	DESCRIPTION
1	2	SIDE PLATE RIVETED SUB ASSEMBLY		
1.1	1	SIDE PLATE	MILD STEEL	
1.2	1	GUIDE	COLD STEEL	
1.3	2	RIVET	STAINLESS STEEL	BUTTON HEAD, Ø10 X 60 LARGE
2	1	AXLE	COLD ROLL STEEL	
3	1	HOOK	STAINLESS STEEL	10 THICK
4	6	COTTER PIN	STAINLESS STEEL	Ø6 X 40 LG
5	12	ADJUSTING WASHER	STEEL	26 INNERØ X 44 OUTERØ X 4 THICK
6	4	WHEEL AXLE	COLD ROLL STEEL	
7	4	WHEEL	COLD STEEL	
8	4	WASHER	STAINLESS STEEL	26 INNERØ X 65 OUTERØ X 3 THICK
9	44	ROLLER BEARING	COLD ROLL STEEL	
10	4	LOCKNUT	STAINLESS STEEL	M16 X 2, PREVAILING TORQUE INSERT-TYPE

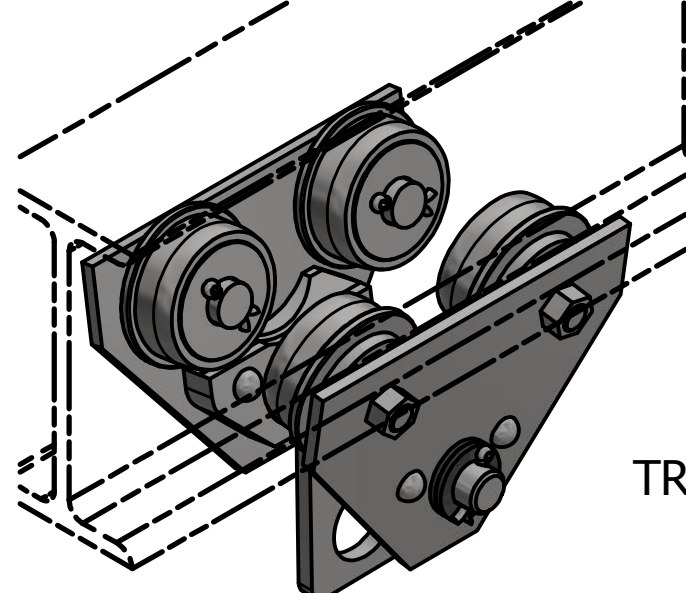

TROLLEY EXPLODED ASSEMBLY  
SCALE 1 / 4

TROLLEY ASSEMBLY  
SCALE 1 / 4

**LEGEND:**

- ∅ DIAMETER
- R RADIUS
- ° DEGREES

METRIC

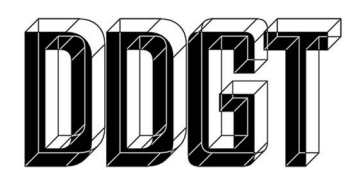

DIGITAL DESIGN  
GRAPHICS  
TECHNOLOGY

WWW.DDGT.NET

**JOHN J. BOLLA**  
Digital Designer

designsjohnj@gmail.com  
ddgt.net/StudentPages/jbolla

Specializing in CAD Design  
and Visualization

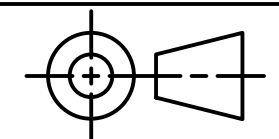

TOLERANCES UNLESS SPECIFIED  
MILLIMETERS:  
WHOLE NUMBER = ± .5  
X = ± .25  
XX = ± .12

ANGLES ± 1 DEGREE

SURFACES 32 ✓

COURSE: DDGT 120

INVENTOR DRAWING NAME:

TROLLEY

FIG #: 14-83

DRAFTER: J. BOLLA

DATE: 12/3/2015

SCALE: AS NOTED

PAGE #: 1 OF 4

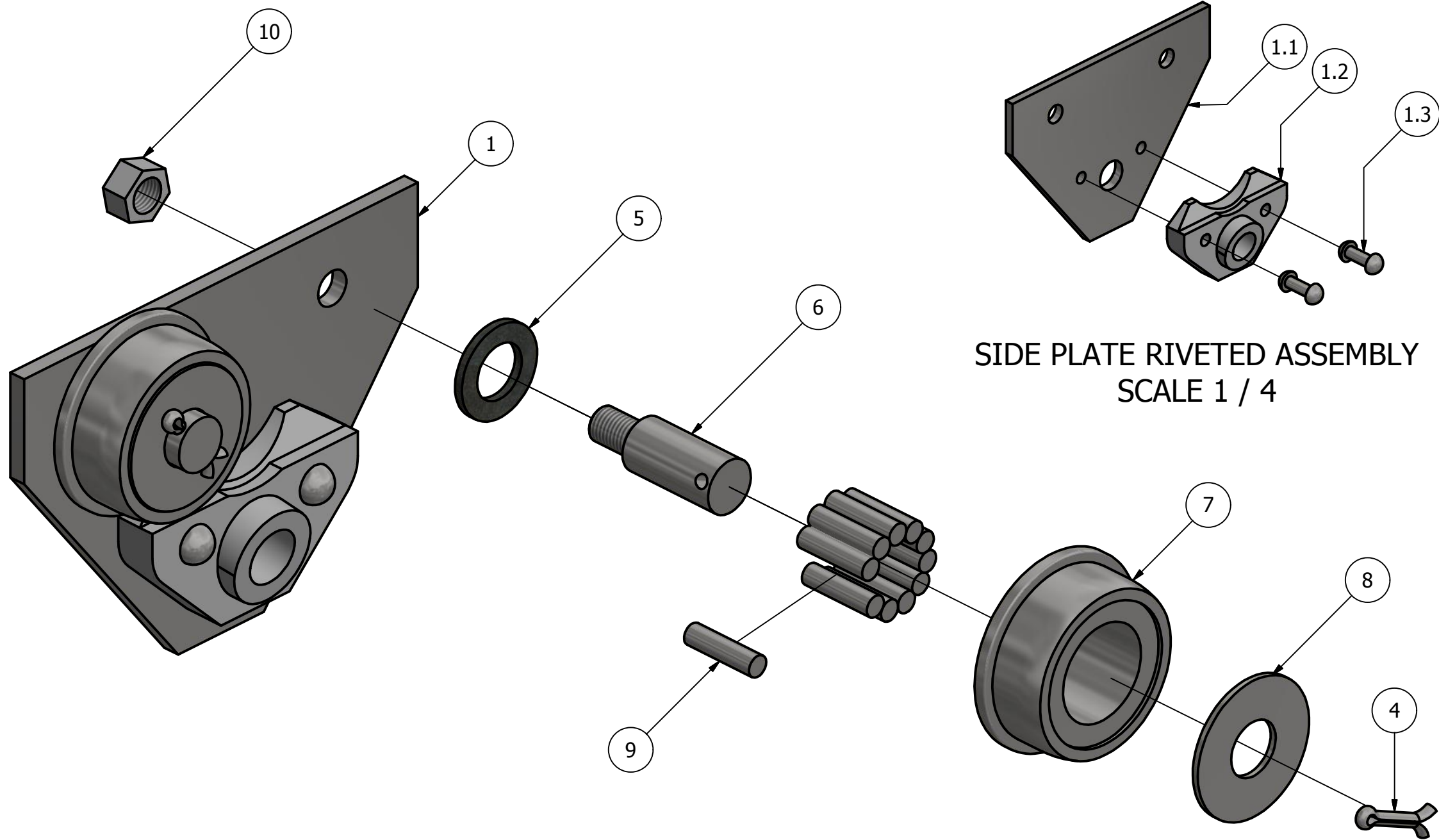

SIDE PLATE RIVETED ASSEMBLY  
SCALE 1 / 4

SIDE PLATE WITH WHEELS EXPLODED ASSEMBLY  
SCALE 1 / 2

PARTS LIST		
ITEM	QTY	PART NUMBER
1	2	SIDE PLATE RIVETED SUB ASSEMBLY
1.1	1	SIDE PLATE
1.2	1	GUIDE
1.3	2	RIVET
4	6	COTTER PIN
5	12	ADJUSTING WASHER
6	4	WHEEL AXLE
7	4	WHEEL
8	4	WASHER
9	44	ROLLER BEARING
10	4	LOCKNUT



DIGITAL DESIGN  
GRAPHICS  
TECHNOLOGY

WWW.DDGT.NET

JOHN J. BOLLA  
Digital Designer

designsjohnj@gmail.com  
ddgt.net/StudentPages/jbolla

Specializing in CAD Design  
and Visualization

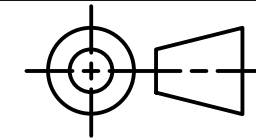

TOLERANCES UNLESS SPECIFIED  
MILLIMETERS:  
WHOLE NUMBER = ± .5  
X = ± .25  
XX = ± .12

ANGLES ± 1 DEGREE

SURFACES 32 ✓

COURSE: DDGT 120

INVENTOR DRAWING NAME:

TROLLEY

FIG #: 14-83

DRAFTER: J. BOLLA

DATE: 12/3/2015

SCALE: AS NOTED

PAGE #: 2 OF 4

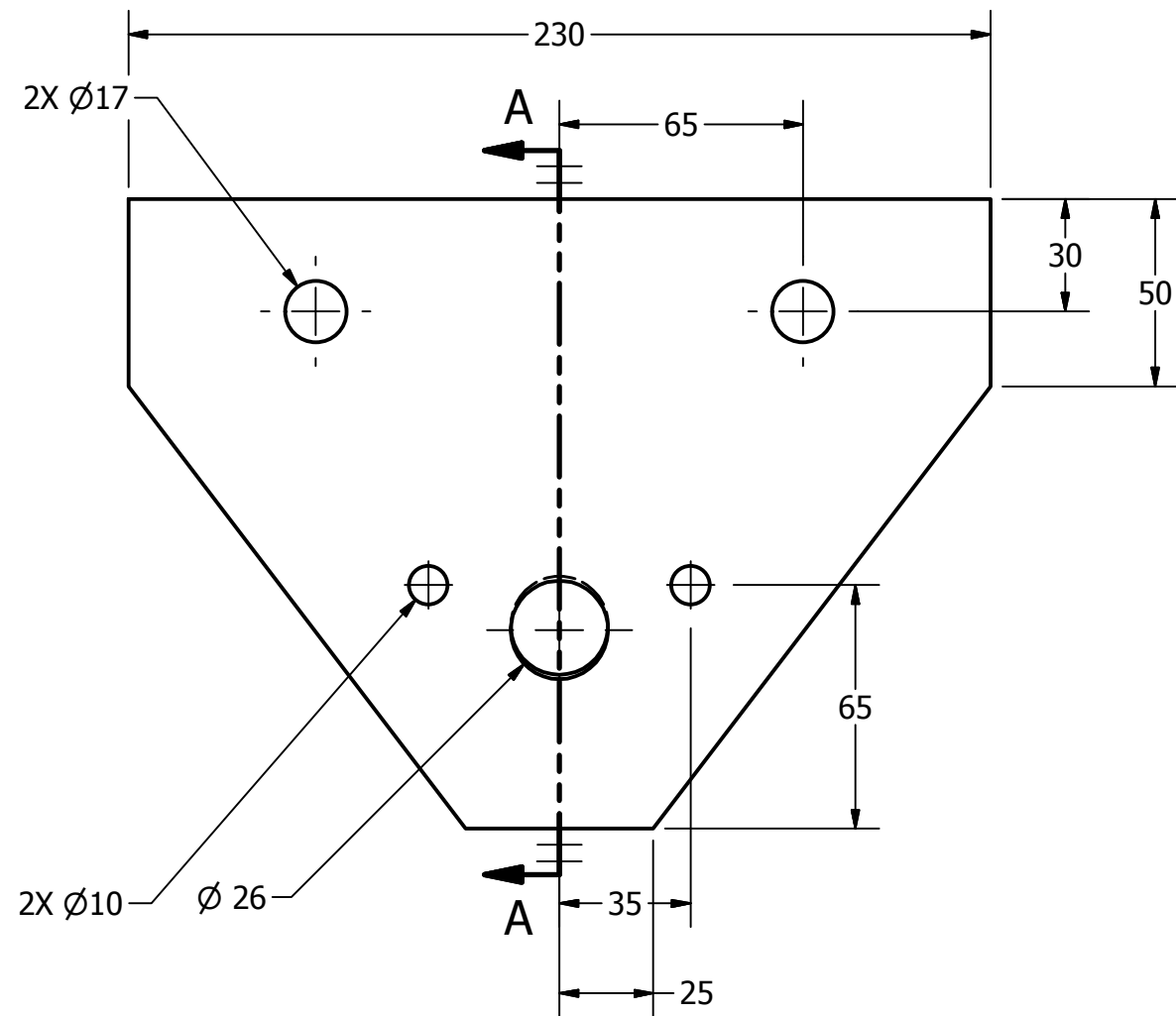

SIDE PLATE  
SCALE 1 / 2

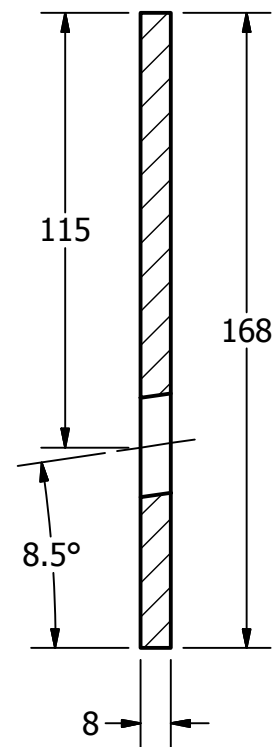

SECTION A-A  
SCALE 1 / 2

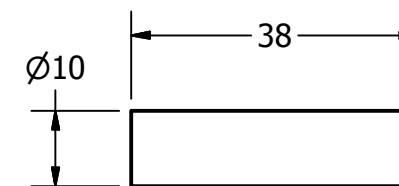
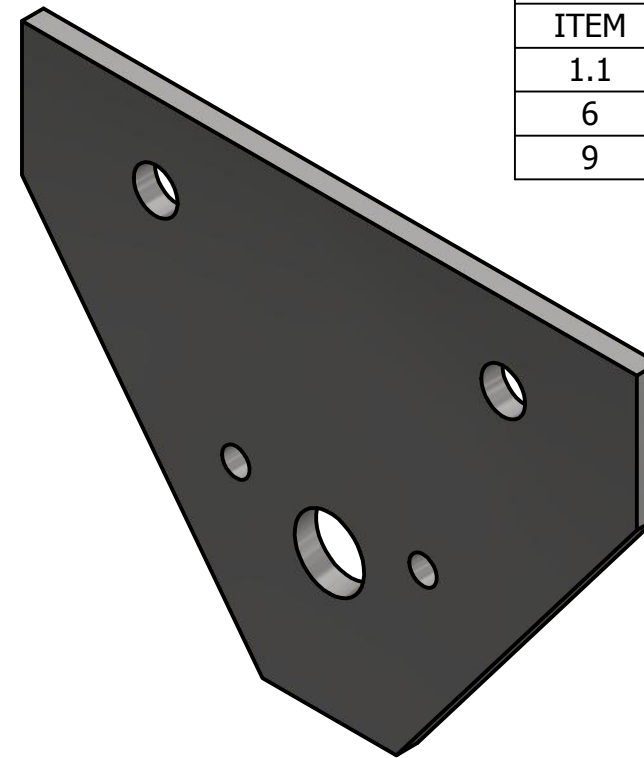

ROLLER BEARING  
SCALE 1 : 1



PARTS LIST		
ITEM	QTY	PART NUMBER
1.1	2	SIDE PLATE
6	4	WHEEL AXLE
9	44	ROLLER BEARING

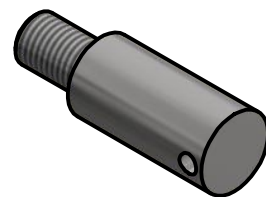
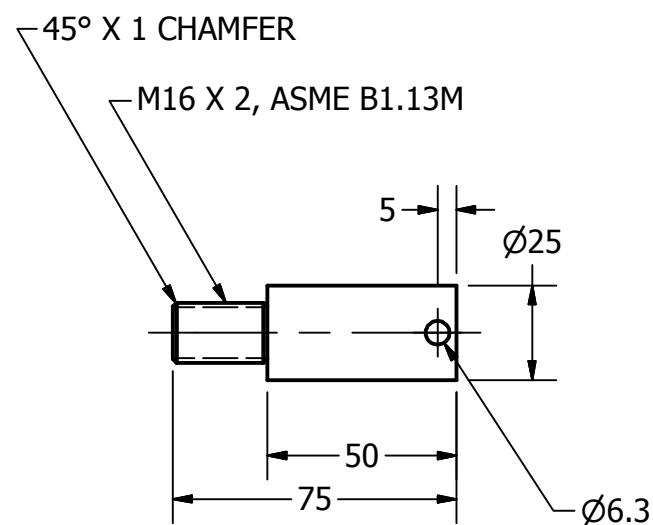

WHEEL AXLE  
SCALE 1 / 2



DIGITAL DESIGN  
GRAPHICS  
TECHNOLOGY

WWW.DDGT.NET

JOHN J. BOLLA  
Digital Designer

designsjohnj@gmail.com  
ddgt.net/StudentPages/jbolla

Specializing in CAD Design  
and Visualization

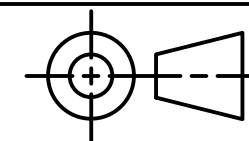

TOLERANCES UNLESS SPECIFIED  
MILLIMETERS:  
WHOLE NUMBER = ± .5  
X = ± .25  
XX = ± .12

ANGLES ± 1 DEGREE

SURFACES 32 ✓

COURSE: DDGT 120

INVENTOR DRAWING NAME:

TROLLEY

FIG #: 14-83

DRAFTER: J. BOLLA

DATE: 12/3/2015

SCALE: AS NOTED

PAGE #: 3 OF 4

PARTS LIST		
ITEM	QTY	PART NUMBER
1.2	2	GUIDE
2	1	AXLE
3	1	HOOK
7	4	WHEEL

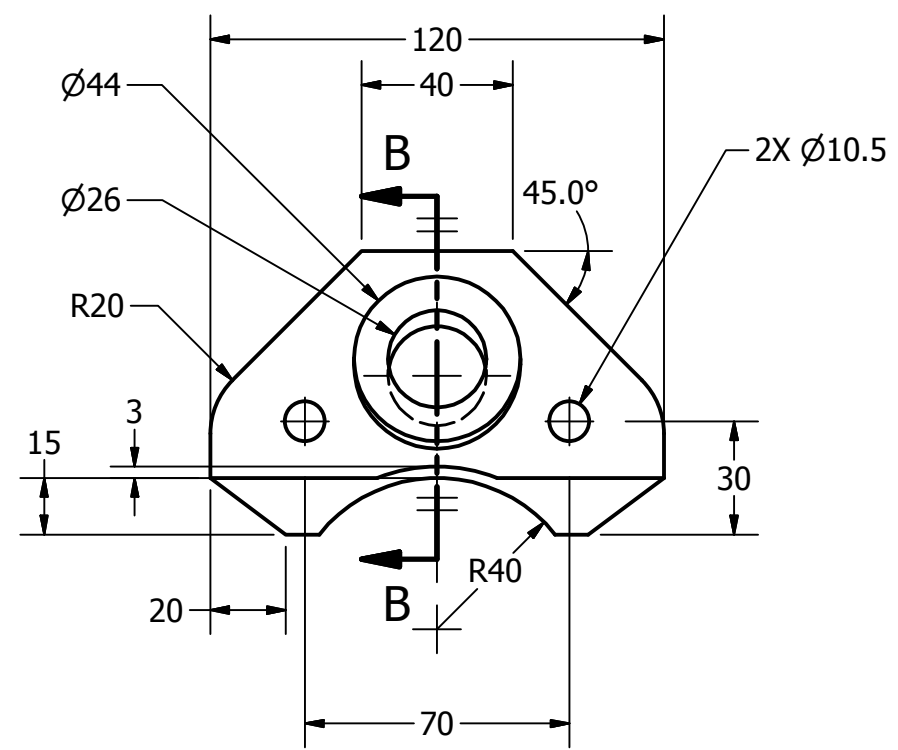

GUIDE  
SCALE 1 / 2

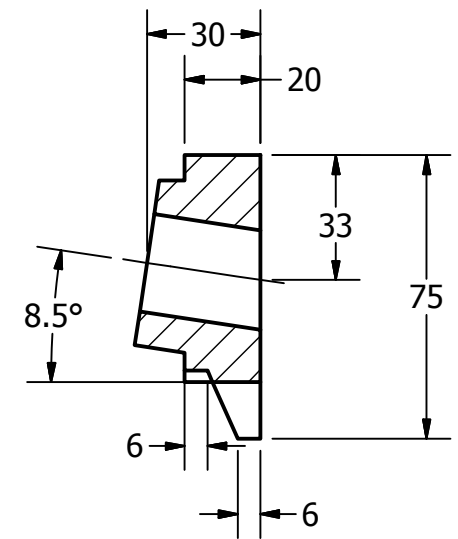

SECTION B-B  
SCALE 1 / 2

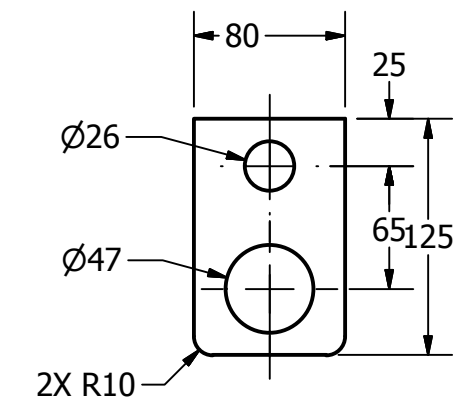
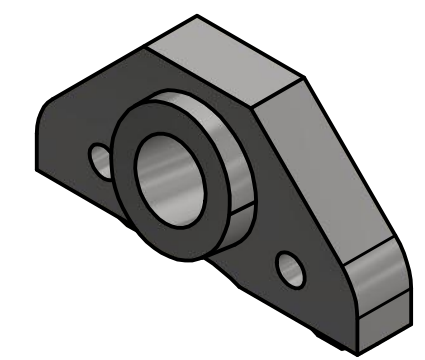

HOOK  
SCALE 1 / 4

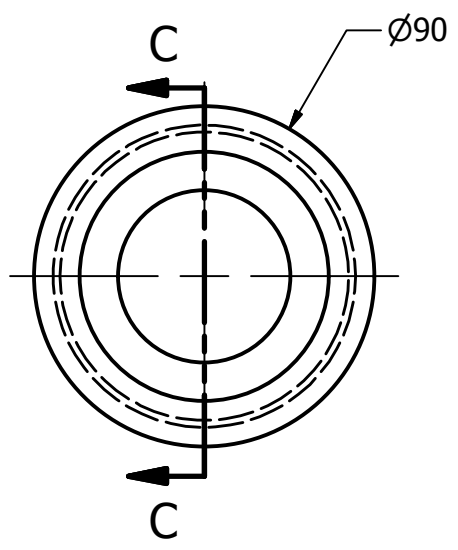
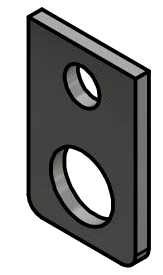

WHEEL  
SCALE 1 / 2

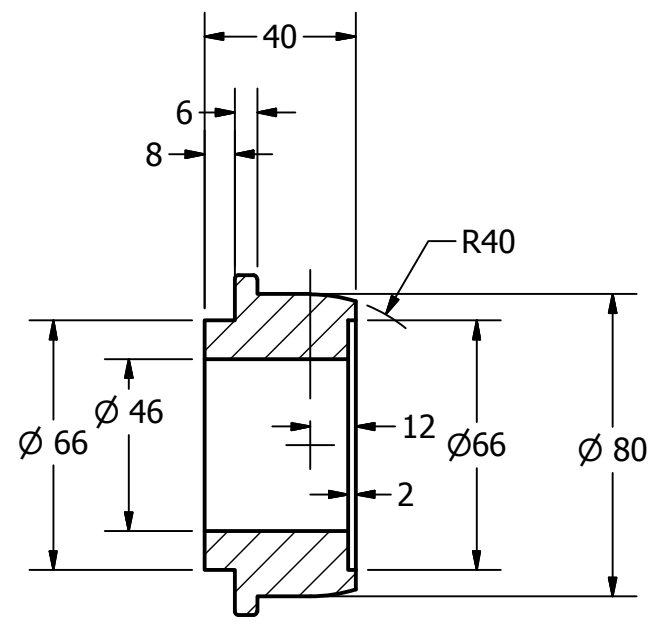

SECTION C-C  
SCALE 1 / 2

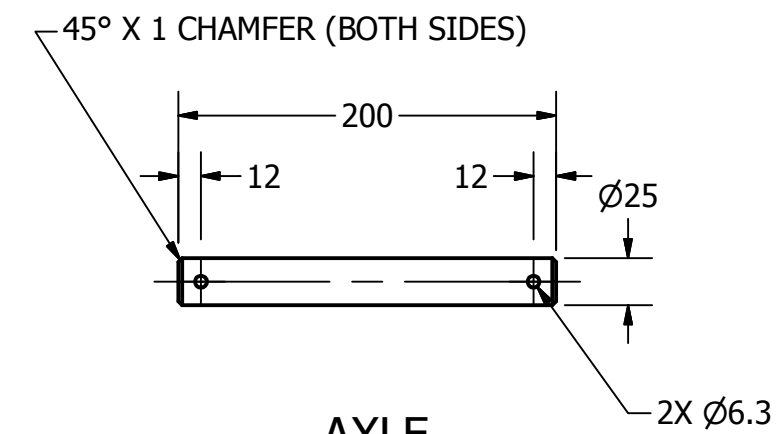
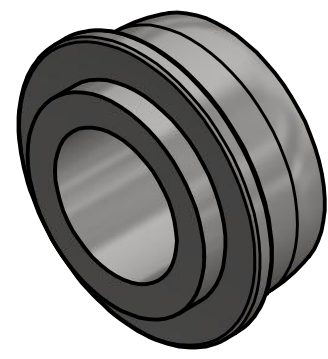

AXLE  
SCALE 1 / 4

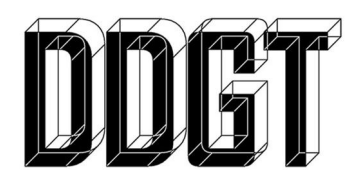
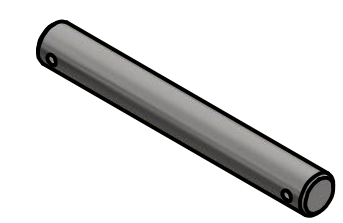

DIGITAL DESIGN  
GRAPHICS  
TECHNOLOGY

WWW.DDGT.NET

JOHN J. BOLLA  
Digital Designer

designsjohnj@gmail.com  
ddgt.net/StudentPages/jbolla

Specializing in CAD Design  
and Visualization

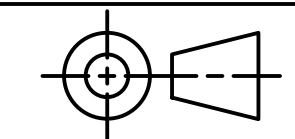

TOLERANCES UNLESS SPECIFIED  
MILLIMETERS:  
WHOLE NUMBER = ± .5  
X = ± .25  
XX = ± .12

ANGLES ± 1 DEGREE

SURFACES 32 ✓

COURSE: DDGT 120

INVENTOR DRAWING NAME:

TROLLEY

FIG #: 14-83

DRAFTER: J. BOLLA

DATE: 12/3/2015

SCALE: AS NOTED

PAGE #: 4 OF 4