

SECTION A-A
SCALE 1 / 2

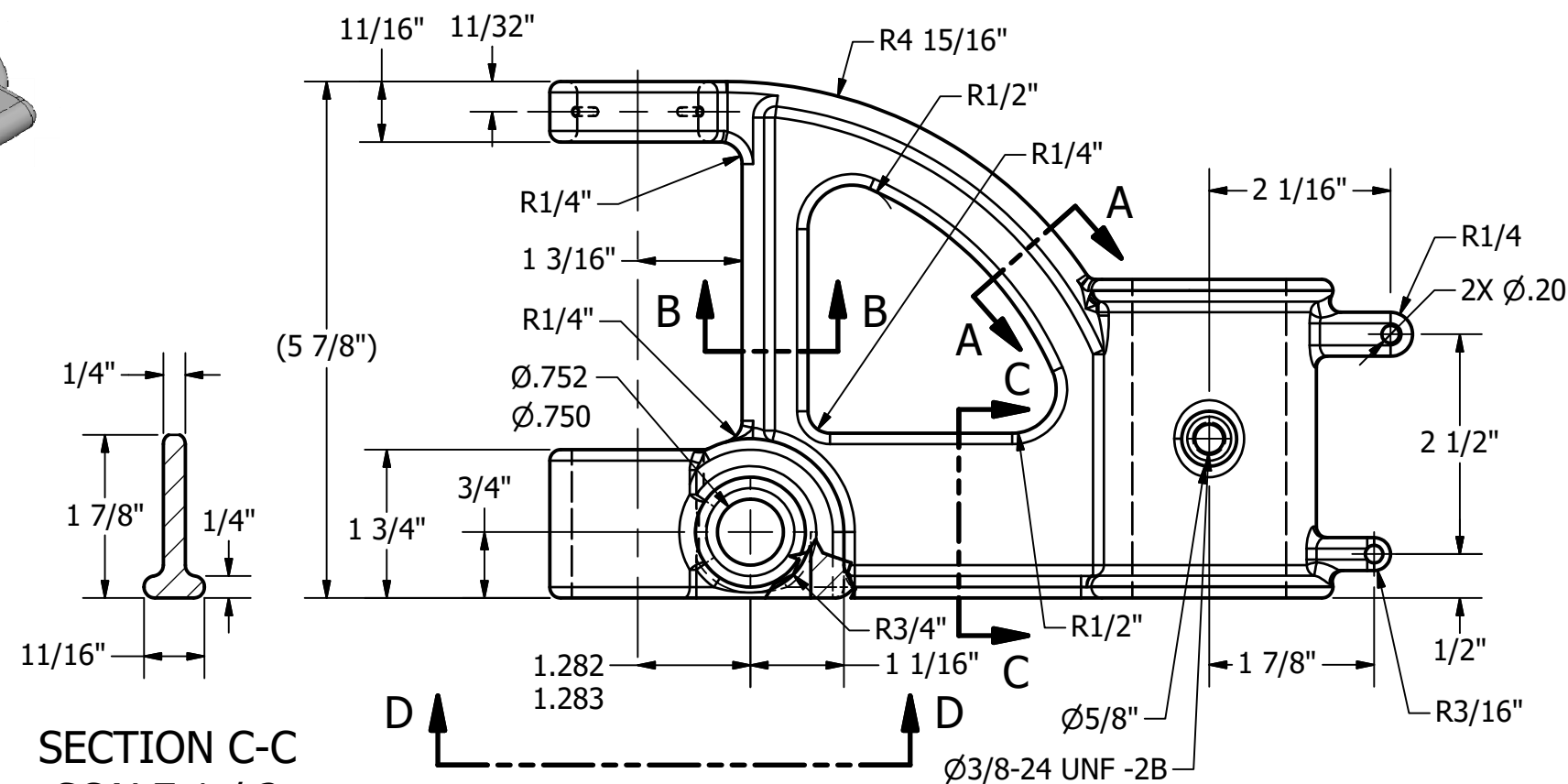

DRILL PRESS BRACKET
SCALE 1/2

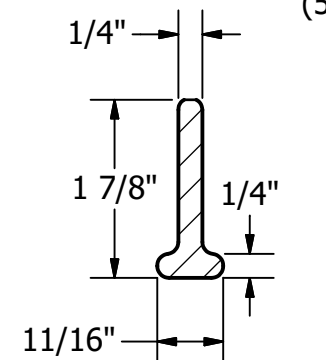

SECTION C-C
SCALE 1 / 2

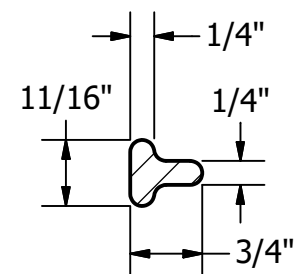

SECTION B-B
SCALE 1 / 2

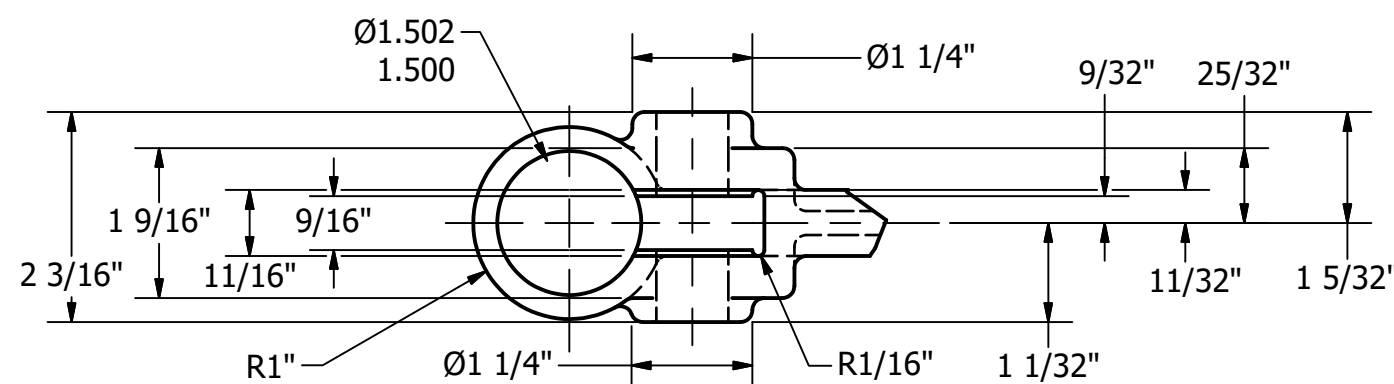

VIEW D-D
SCALE 1 / 2

PARTS LIST			
ITEM	QTY	PART NUMBER	DESCRIPTION
1	1	DRILL PRESS BRACKET	STEEL, CARBON



DIGITAL DESIGN
GRAPHICS
TECHNOLOGY

WWW.DDGT.NET

GENERAL NOTES:
ROUNDS AND FILLETS
R1/8 UNLESS
OTHERWISE SPECIFIED

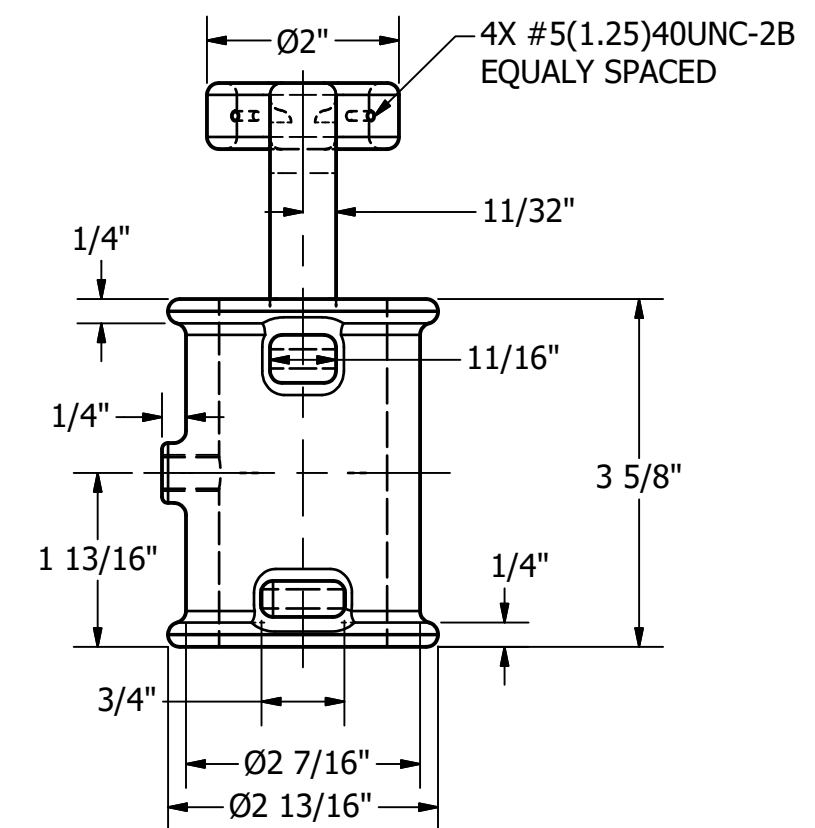

LEGEND:

- Ø DIAMETER
- R RADIUS
- ° DEGRES
- ∇ DEPTH

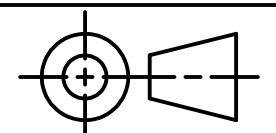

TOLERANCES UNLESS SPECIFIED:
DECIMAL INCHES:
X = ±.020
XX = ±.010
XXX = ±.005
FRACTIONAL ±1/64"
ANGLES ±1 DEGREE
SURFACES 32/

COURSE: DDGT120

INVENTOR DRAWING NAME:
DRILL PRESS BRACKET

FIG #: 14-35

DRAFTER: F. MORALES

DATE: 11/28/2017

SCALE: AS NOTED

PAGE #: 1 OF 1