

EXPLODED ENGINE MODEL ASSEMBLY
SCALE 1 / 4

METRIC

PARTS LIST			
ITEM	QTY	PART NUMBER	MATERIAL
1	1	ENGINE BLOCK	ALUMINIUM 6061
2	3	CONNECTING ROD	
2.1	1	CONNECTING ROD TOP	STEEL
2.2	1	CONNECTING ROD BOTTOM	STEEL
2.3	2	ANSI B18.2.3.1M - M5 x 0.8 x 25	MILD STEEL
3	3	PISTON PIN	STEEL
4	3	PISTON	STEEL
5	1	CRANK SHAFT	STEEL

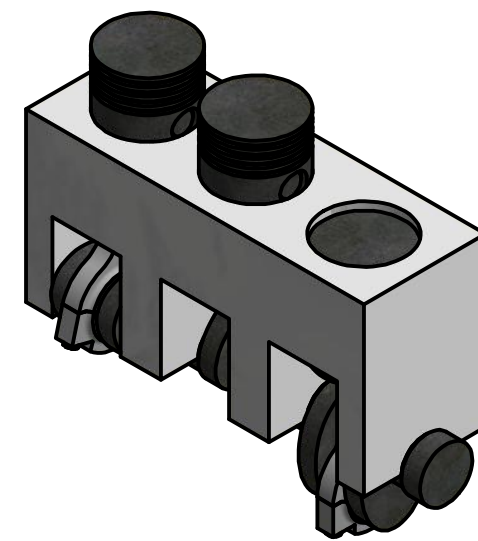

ENGINE MODEL ASSEMBLY
SCALE 1 / 4

GENERAL NOTES: FILLETS TO BE R3
ALL CHAMFERS 2 X 45 DEGREES

LEGEND:

- ∅ DIAMETER
- R RADIUS
- ° DEGREE
- ∇ DEPTH

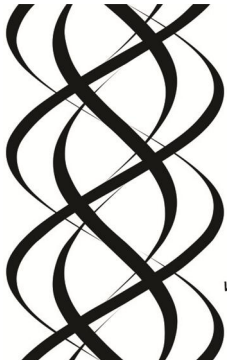
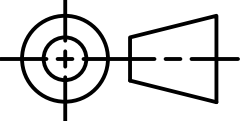
 DIGITAL DESIGN GRAPHICS TECHNOLOGY WWW.DDGT.NET	 Alexandar Kuykendall Draftsman and Graphic Designer (707) 980-5920 alexjkuykendall@gmail.com www.ddgt.net/StudentPages/akuykendall	 TOLERANCES UNLESS SPECIFIED MILLIMETERS: WHOLE NUMBERS = ±.5 X = ±.25 XX = ±.12 ANGLES ± 1 DEGREE SURFACES $\sqrt{32}$	COURSE: DDGT 240
			INVENTOR DRAWING NAME: ENGINE MODEL
			FIG #: 1048
			DRAFTER: A. KUYKENDALL
			DATE: 11/15/2016
			SCALE: AS NOTED
			PAGE #: 1 OF 4

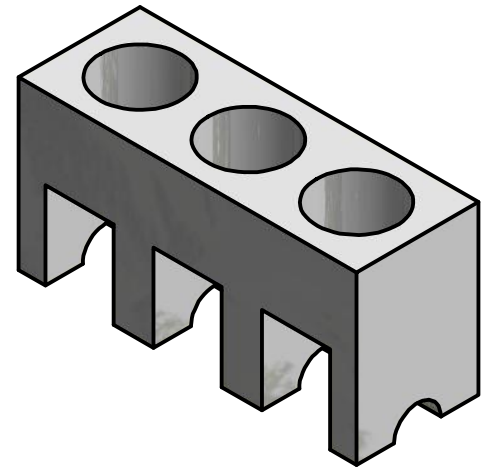

ENGINE BLOCK
SCALE 1 / 4

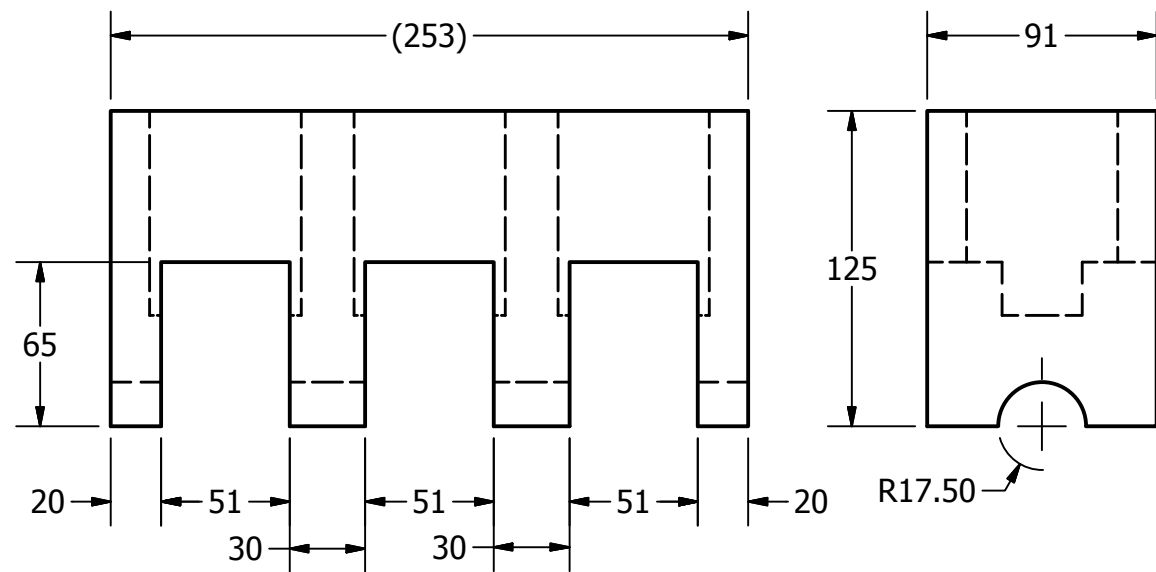
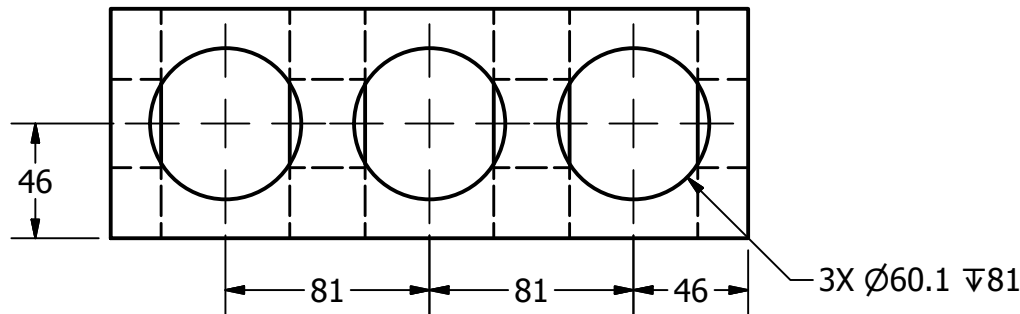

ENGINE BLOCK
SCALE 1/3



PISTON
SCALE 1 / 2

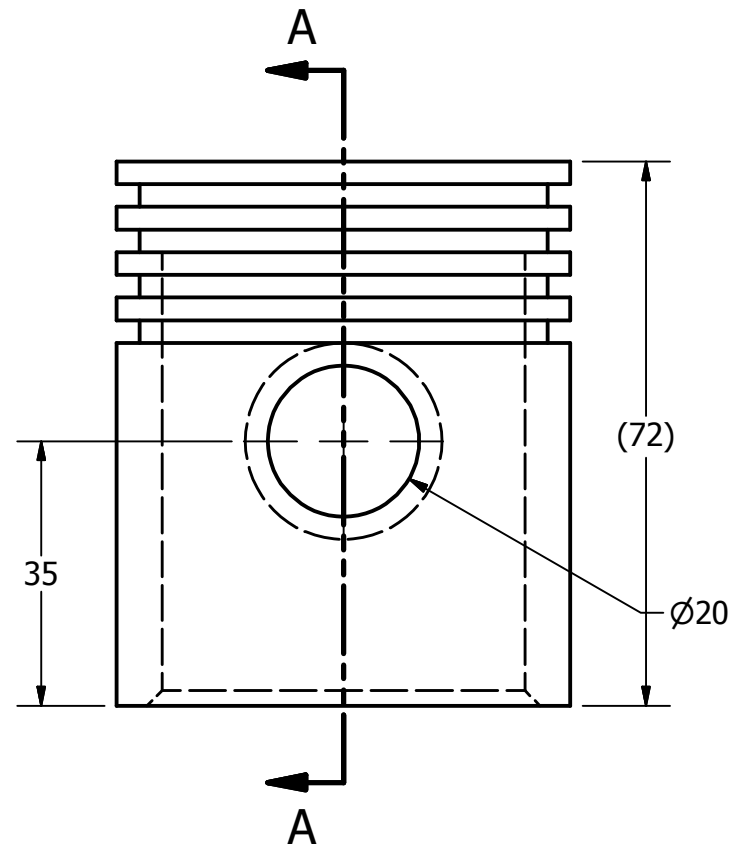

PISTON
SCALE 1 : 1

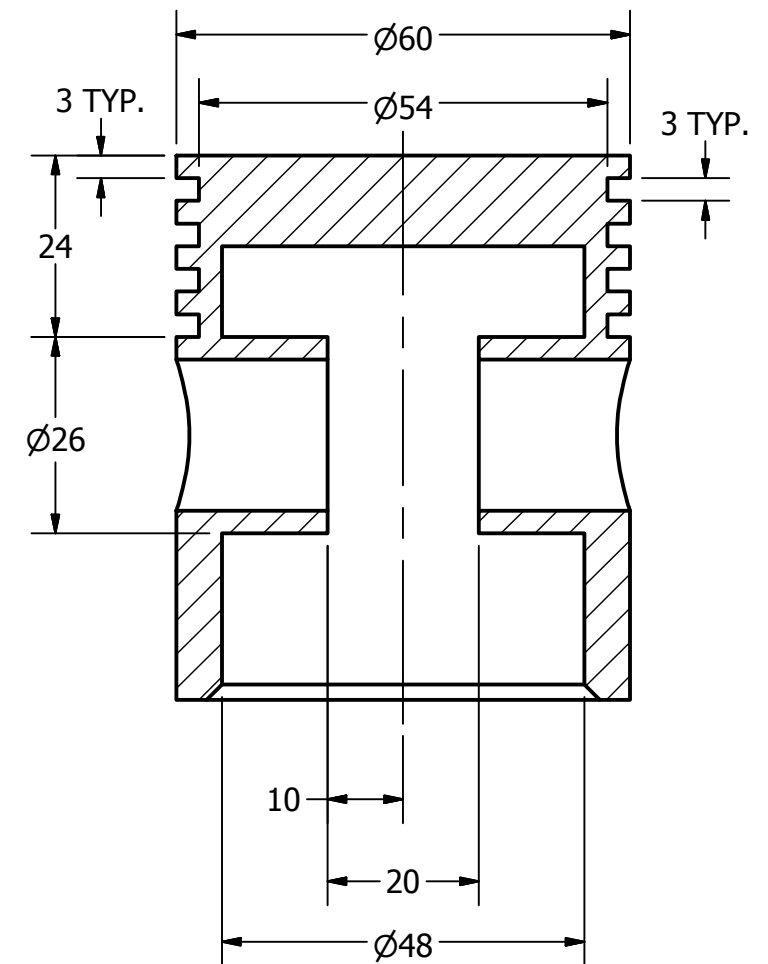

SECTION A-A
SCALE 1 : 1

LEGEND:

- Ø DIAMETER
- R RADIUS
- ° DEGREE
- ∇ DEPTH

PARTS LIST		
ITEM	QTY	PART NUMBER
1	1	ENGINE BLOCK
4	3	PISTON



DIGITAL DESIGN
GRAPHICS
TECHNOLOGY

WWW.DDGT.NET

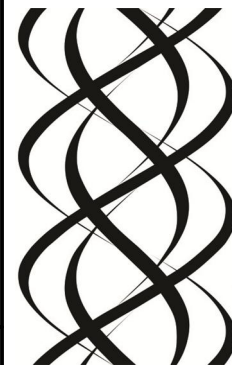

Alexzander Kuykendall

Draftsman and Graphic Designer

(707) 980-5920

alexjkuykendall@gmail.com

www.ddgt.net/StudentPages/akuykendall

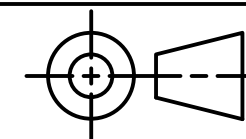

TOLERANCES UNLESS SPECIFIED
MILIMETERS:
WHOLE NUMBERS = ±.5
X = ±.25
XX = ±.12
ANGLES ± 1 DEGREE

SURFACES 32/√

COURSE: DDGT 240

INVENTOR DRAWING NAME:

ENGINE MODEL

FIG #: 1048

DRAFTER: A. KUYKENDALL

DATE: 11/15/2016

SCALE: AS NOTED

PAGE #: 2 OF 4

PARTS LIST		
ITEM	QTY	PART NUMBER
2.1	3	CONNECTING ROD TOP
2.2	3	CONNECTING ROD BOTTOM
3	3	PISTON PIN

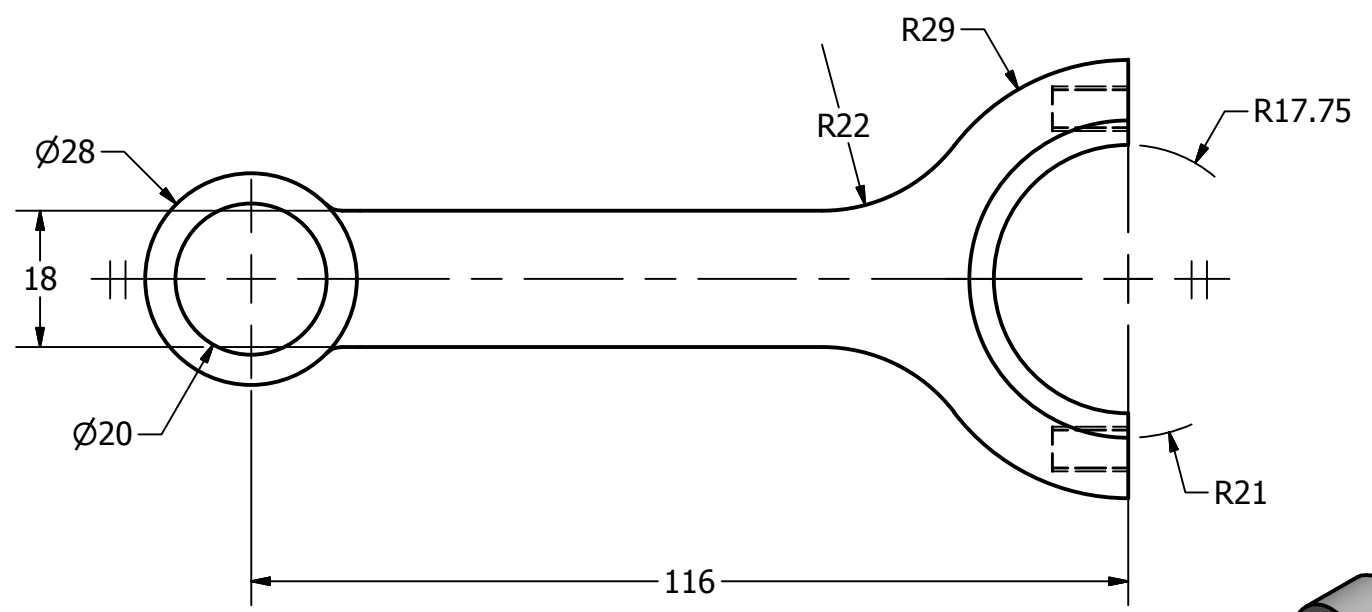
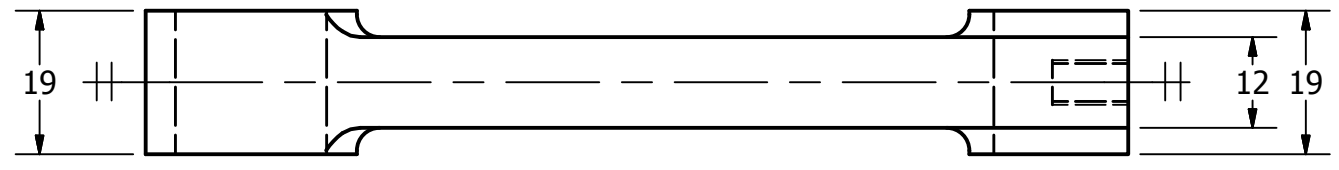

CONNECTING ROD TOP
SCALE 1 : 1

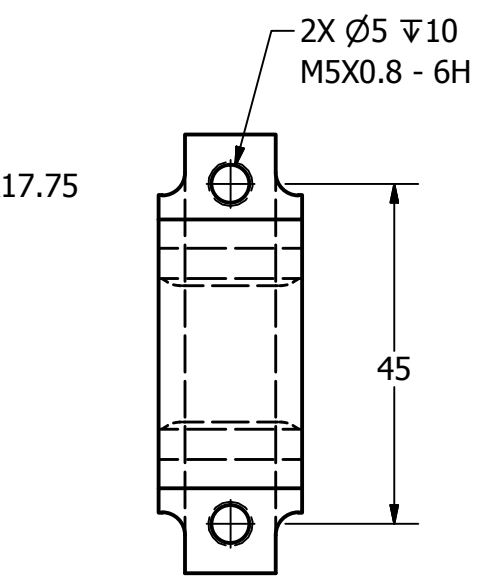

CONNECTING ROD TOP
SCALE 1 / 2

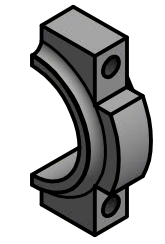
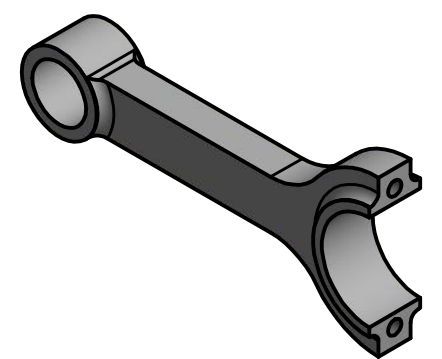

CONNECTING ROD BOTTOM
SCALE 1 / 2

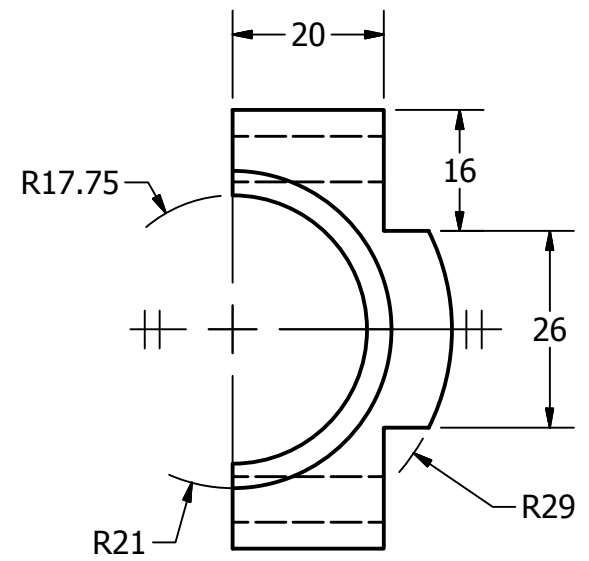

CONNECTING ROD BOTTOM
SCALE 1 : 1

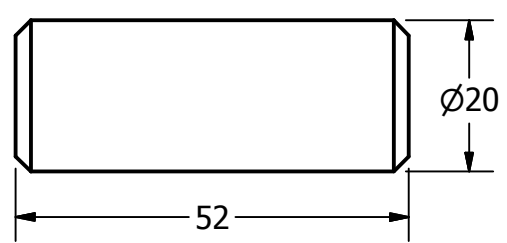
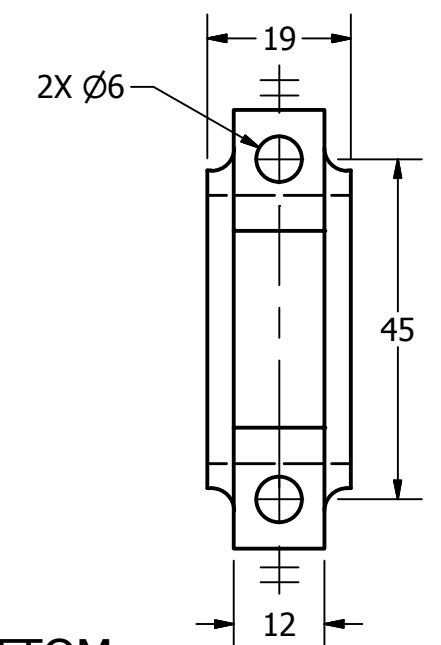

PISTON PIN
SCALE 1 : 1



PISTON PIN
SCALE 1 / 2

LEGEND:

- ∅ DIAMETER
- R RADIUS
- ° DEGREE
- ∇ DEPTH

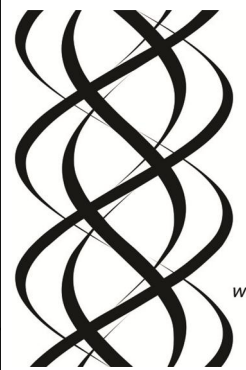
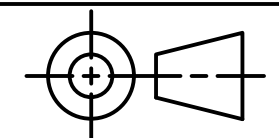
 DIGITAL DESIGN GRAPHICS TECHNOLOGY WWW.DDGT.NET	 Alexandar Kuykendall Draftsman and Graphic Designer (707) 980-5920 alexjkuykendall@gmail.com www.ddgt.net/StudentPages/akuykendall	 TOLERANCES UNLESS SPECIFIED MILLIMETERS: WHOLE NUMBERS = ±.5 X = ±.25 XX = ±.12 ANGLES ± 1 DEGREE SURFACES $\sqrt{32}$	COURSE: DDGT 240
			INVENTOR DRAWING NAME: ENGINE MODEL
		FIG #: 1048	DRAFTER: A. KUYKENDALL
		DATE: 11/15/2016	SCALE: AS NOTED
		PAGE #: 3 OF 4	

PARTS LIST		
ITEM	QTY	PART NUMBER
5	1	CRANK SHAFT



CRANK SHAFT
SCALE 1 / 2

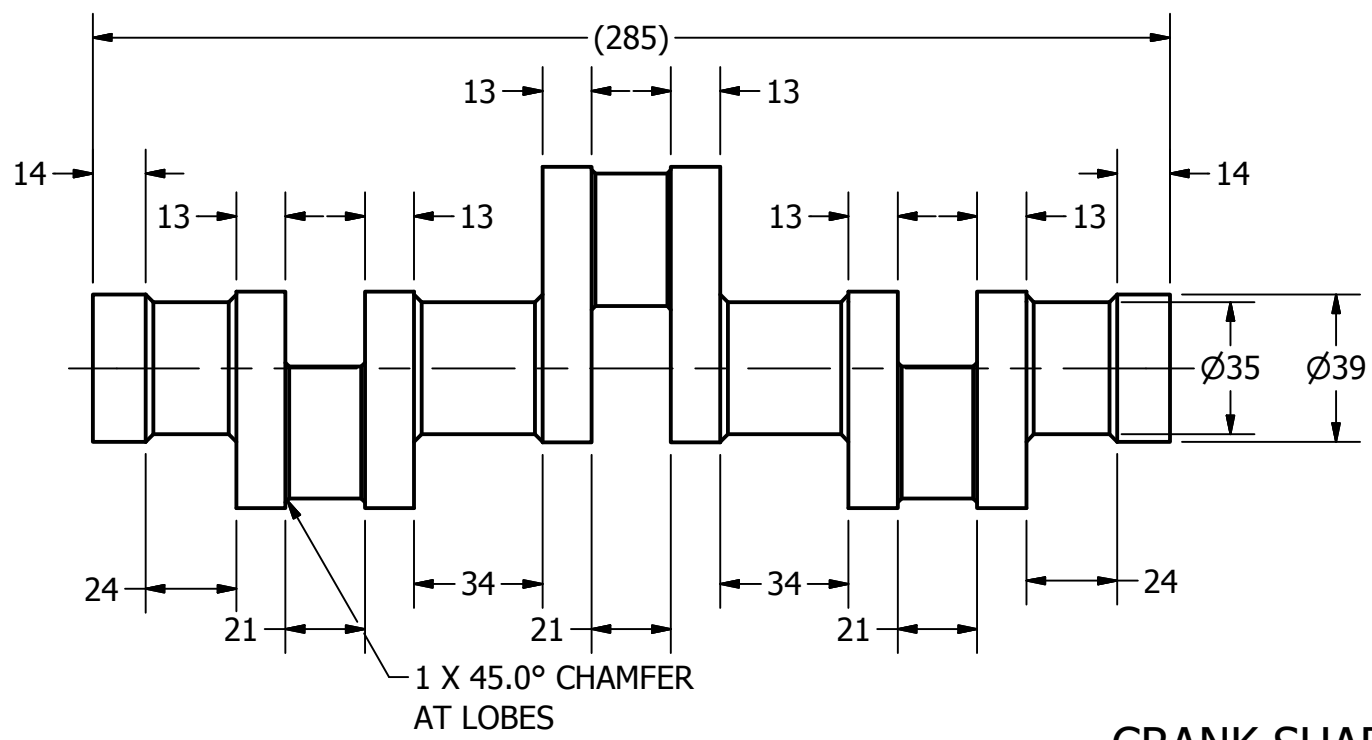

CRANK SHAFT
SCALE 1 / 2

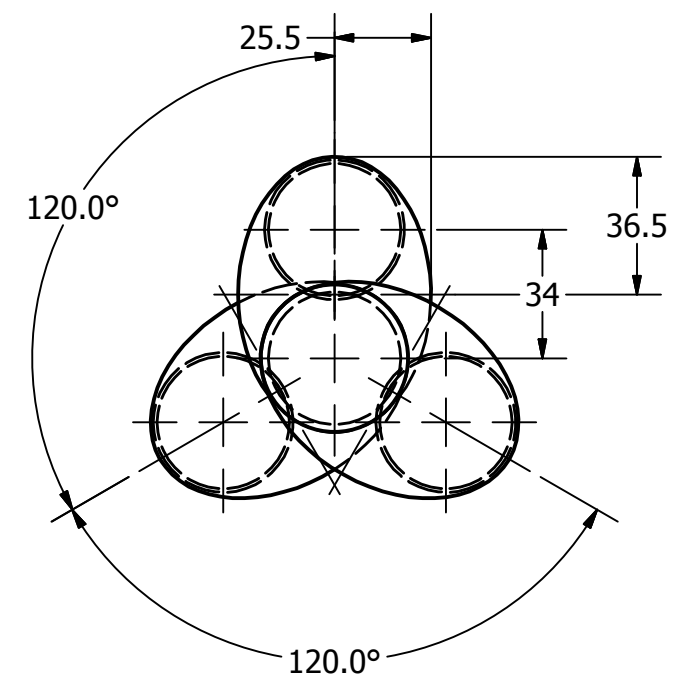

DDGT
DIGITAL DESIGN
GRAPHICS
TECHNOLOGY
WWW.DDGT.NET

 **Alexzander Kuykendall**
Draftsman and Graphic Designer
(707) 980-5920
alexjkuykendall@gmail.com
www.ddgt.net/StudentPages/akuykendall

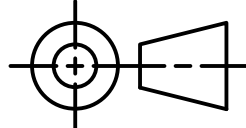
TOLERANCES UNLESS SPECIFIED
MILIMETERS:
WHOLE NUMBERS = $\pm .5$
X = $\pm .25$
XX = $\pm .12$
ANGLES ± 1 DEGREE
SURFACES $\sqrt{32}$

COURSE: DDGT 240
INVENTOR DRAWING NAME:
ENGINE MODEL
FIG #: 1048
DRAFTER: **A. KUYKENDALL**
DATE: 11/15/2016
SCALE: **AS NOTED**
PAGE #: 4 OF 4