

4

3

2

1

PARTS LIST

ITEM	QTY	PART NUMBER	DESCRIPTION	MATERIAL
1	2	PT 1 SIDEPLATE		MST
2	2	PT 2 GUIDE		CI
3	1	PT 3 AXLE		CRS
4	1	PT 4 HOOK		DNL
5	44	PT 5 ROLLER BEARING		CRS
6	4	PT 6 WHEEL		CI
7	4	PT 7 AXLE		CRS
8	12	PT 8 ADJUSTING WASHER	26 ID X 44 OD X 4 THK	STL
9	4	PT 9 RIVET	BUTTON HEAD, 10 DIA X 60 LG	DNL
10	4	PT 10 WASHER	26 ID X 65 OD X 3 THK	DNL
11	4	PT 11 LOCKNUT	M16 X 2	DNL
12	6	PT 12 COTTER PIN	6 DIA X 40 LG	DNL
13	1	PT 13 I-BEAM	S200 X 34	N/A
14	2	SIDEPLATE ASSEMBLY		
15	4	WHEEL ASSEMBLY		

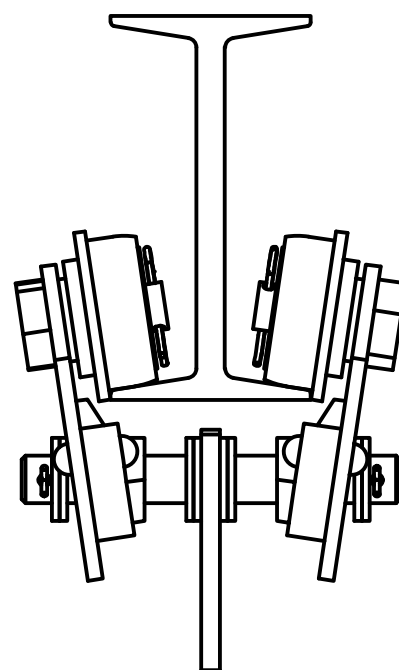
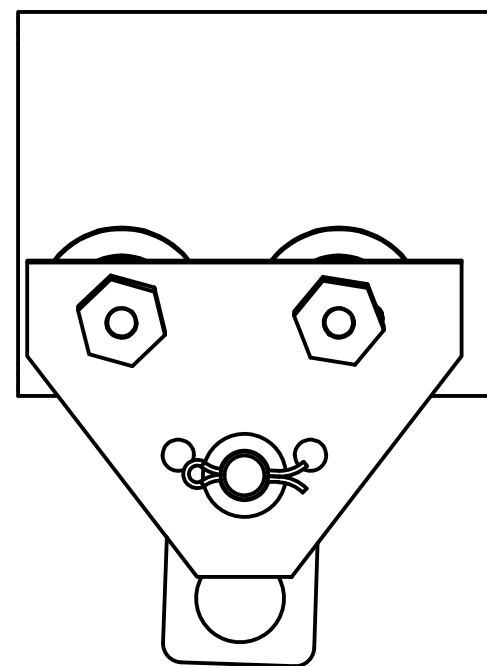
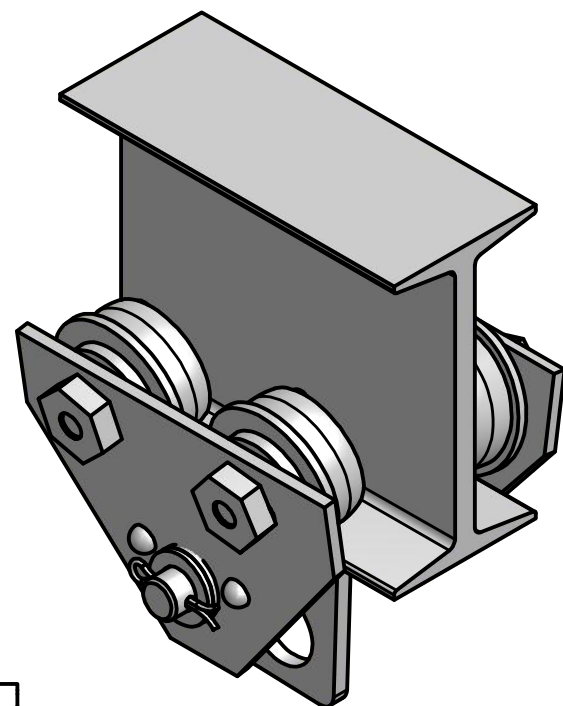

TROLLEY ASSEMBLY
SCALE 1 / 4

DRAWN	ASHLEY JORGENSEN	2/8/2010		
CHECKED				
QA			TITLE	
MFG			TROLLEY ASSEMBLY	
APPROVED				
			SIZE	DWG NO
			B	FIG. 14-83
			SCALE	REV
			SHEET 1 OF 10	

TROLLEY SHOULD BE MOUNTED ON AN S200X34 I-BEAM.

ADJUSTING WASHER 26 ID X 44 OD X 4 THK, 12 REQD, MATL - STL.

RIVET, BUTTON HEAD, Ø10 X 60 LG, 4 REQD.

WASHER 26 ID X 65 OD X 3 THK, 4 REQD.

LOCKNUT M16 X 2, 4 REQD. PREVAILING TORQUE INSERT-TYPE.

COTTER PIN Ø6 X 40 LG, 6 REQD.

PARTS LIST		
PART #	QTY	PART NAME
1	2	SIDEPLATE
2	2	GUIDE
3	1	AXLE
4	1	HOOK
5	44	ROLLER BEARING
6	4	WHEEL
7	4	AXLE
8	12	ADJUSTING WASHER
9	4	RIVET
10	4	WASHER
11	4	LOCKNUT
12	6	COTTER PIN
13	1	I-BEAM
14	2	SIDEPLATE ASSEMBLY
15	4	WHEEL ASSEMBLY

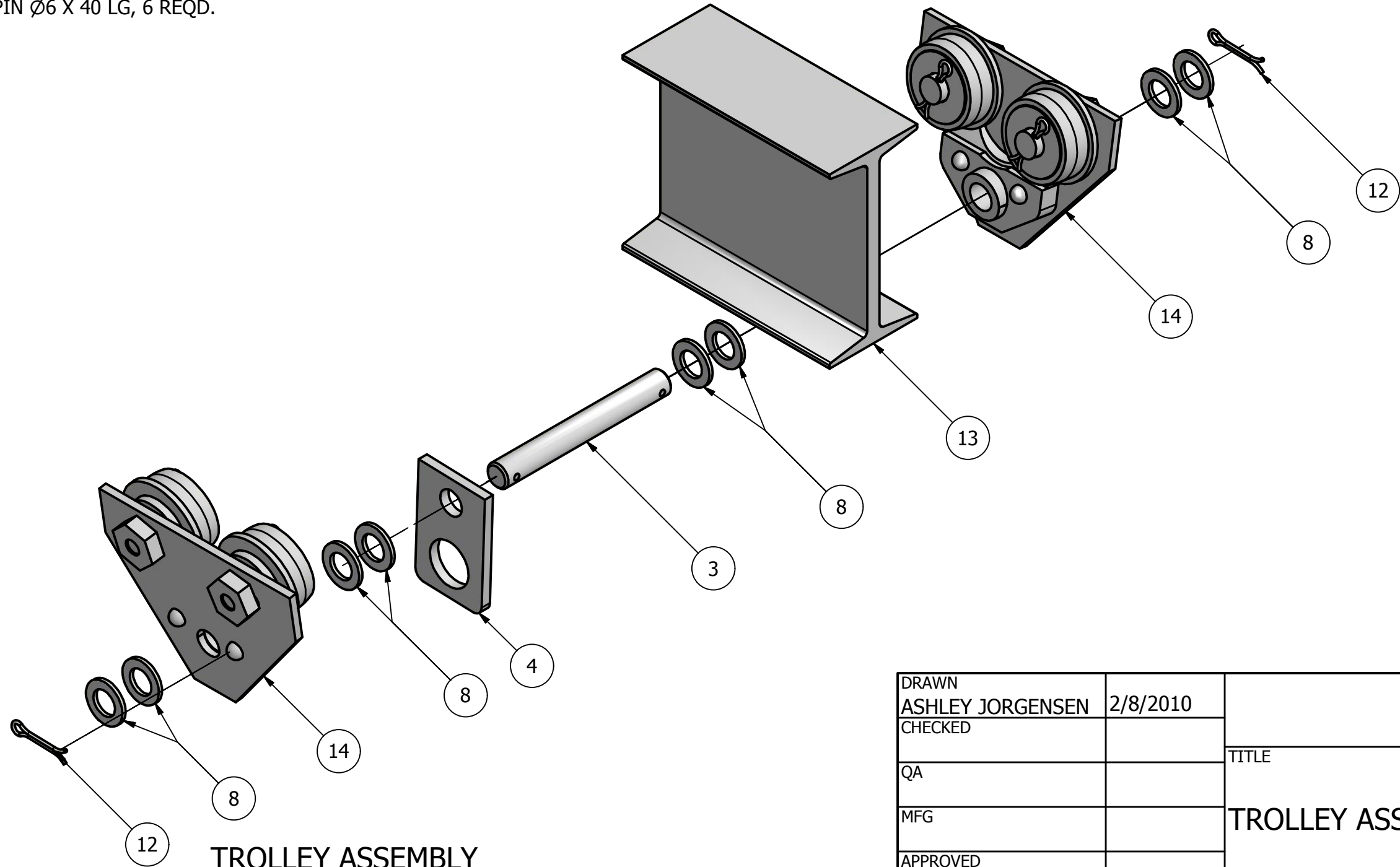

TROLLEY ASSEMBLY
SCALE 1 / 4

DRAWN	ASHLEY JORGENSEN	2/8/2010		
CHECKED				
QA			TITLE	
MFG			TROLLEY ASSEMBLY	
APPROVED				
		SIZE	DWG NO	REV
		B	FIG. 14-83	
		SCALE	SHEET 2 OF 10	

PARTS LIST		
ITEM	QTY	PART NUMBER
1	1	PT 1 SIDE PLATE
2	1	PT 2 GUIDE
9	2	PT 9 RIVET
11	2	PT 11 LOCKNUT
15	2	WHEEL ASSEMBLY

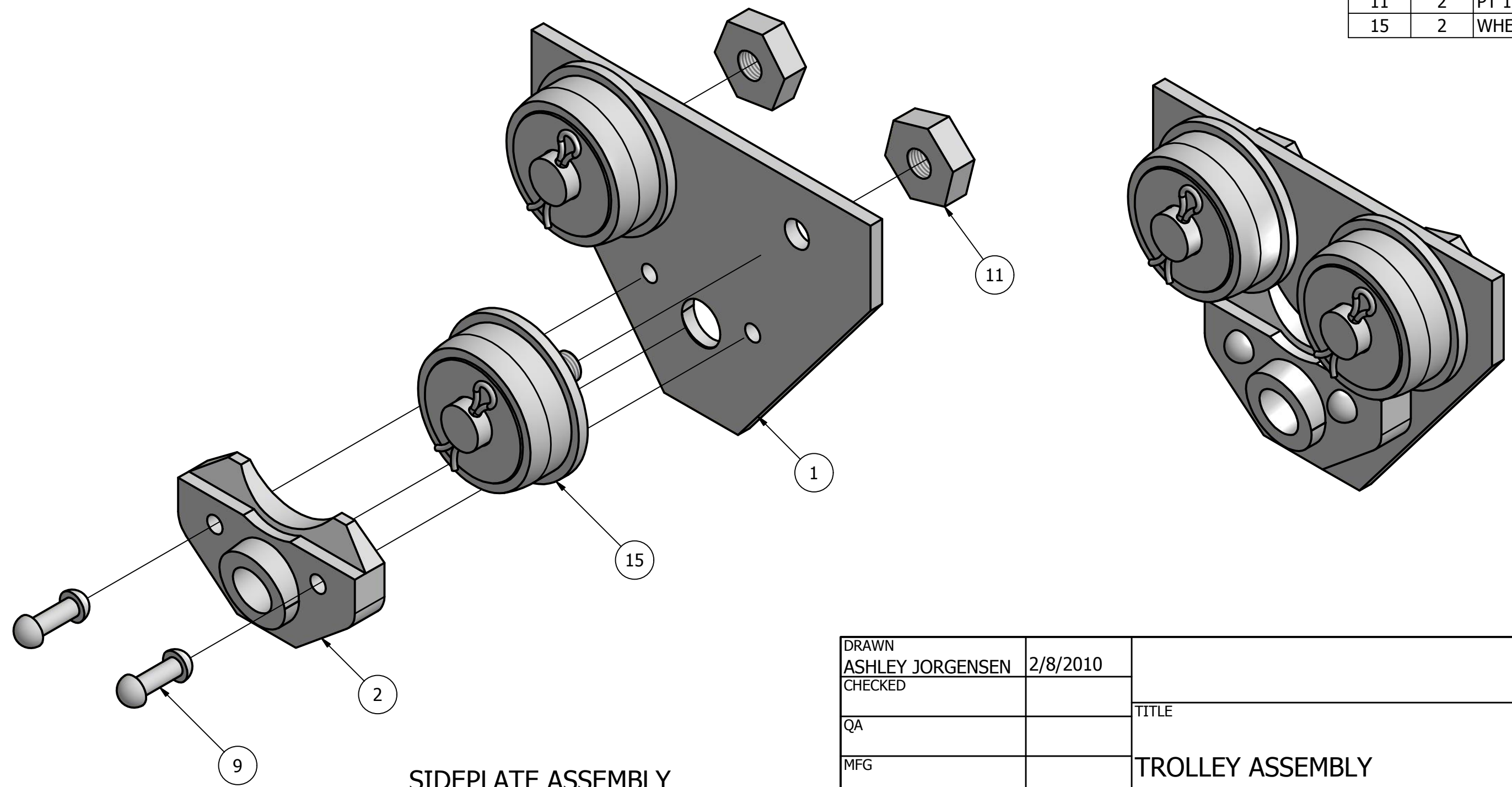

SIDEPLATE ASSEMBLY
SCALE 1 / 2

DRAWN	ASHLEY JORGENSEN	2/8/2010		
CHECKED			TITLE	
QA			TROLLEY ASSEMBLY	
MFG				
APPROVED				
			SIZE	DWG NO
			B	FIG. 14-83
			SCALE	REV
				SHEET 3 OF 10

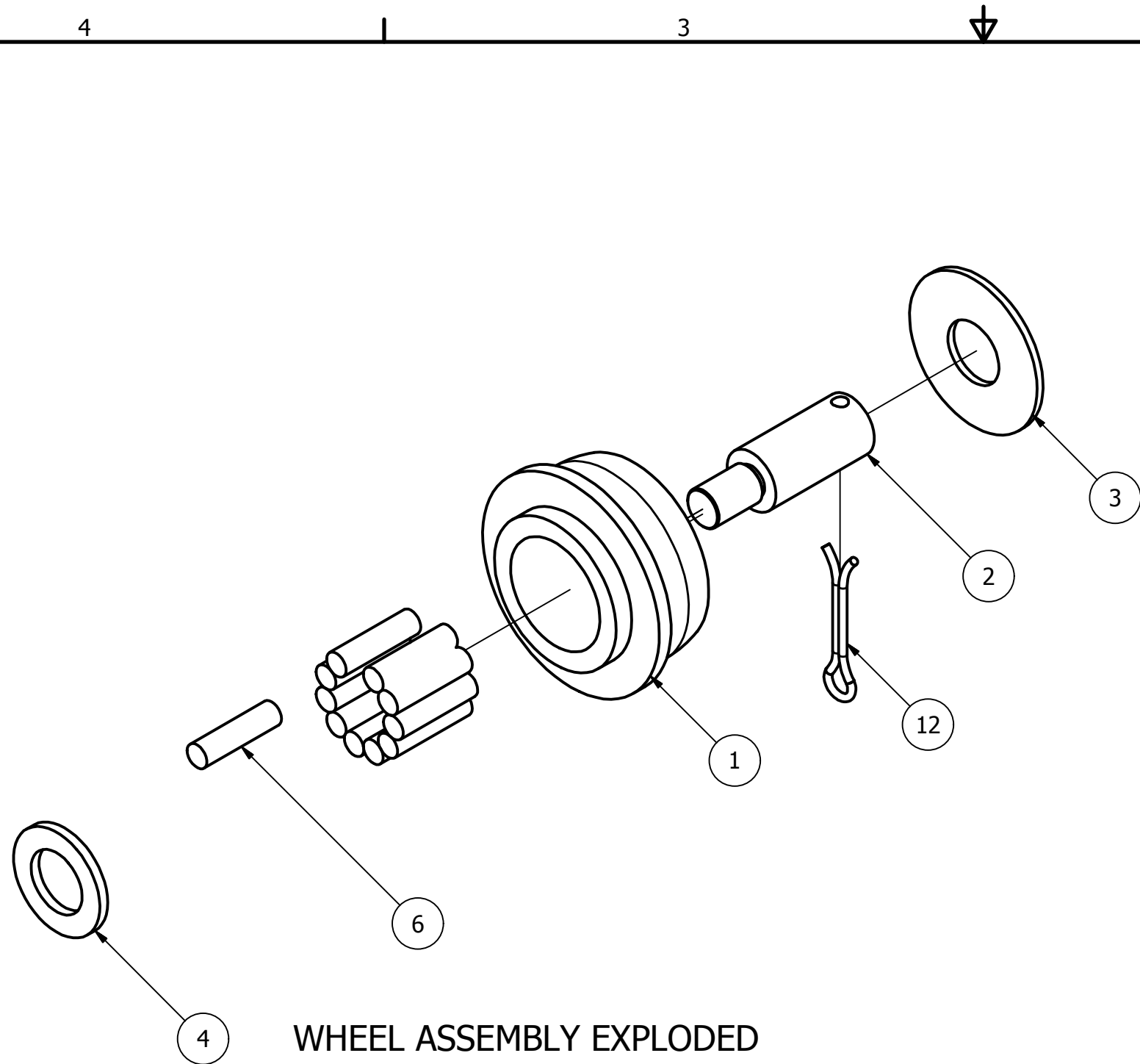

WHEEL ASSEMBLY EXPLODED
SCALE 1 / 2

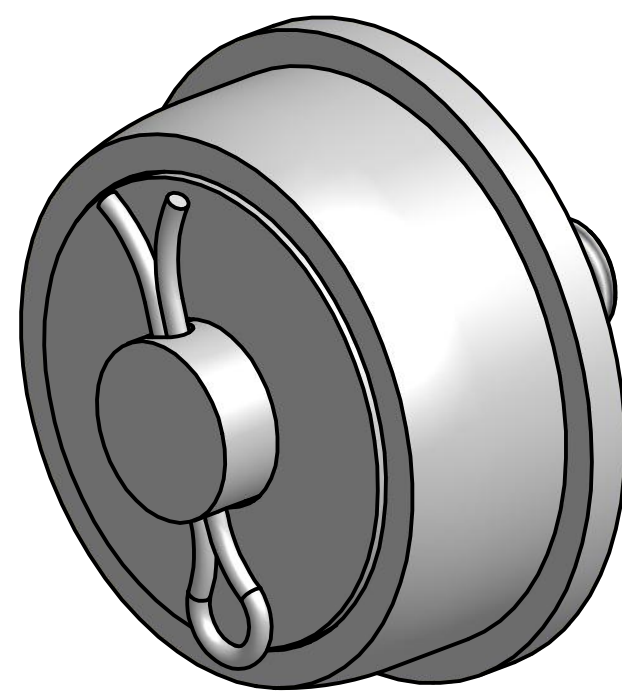

DRAWN	ASHLEY JORGENSEN	2/8/2010		
CHECKED				
QA			TITLE	
MFG			TROLLEY ASSEMBLY	
APPROVED			SIZE	DWG NO
			B	FIG. 14-83
			SCALE	SHEET 4 OF 10
				REV

PARTS LIST			
ITEM	QTY	PART NUMBER	MATERIAL
1	2	PT 1 SIDE PLATE	MST

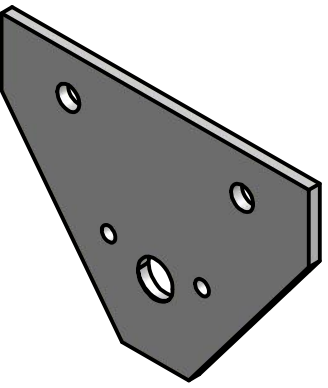
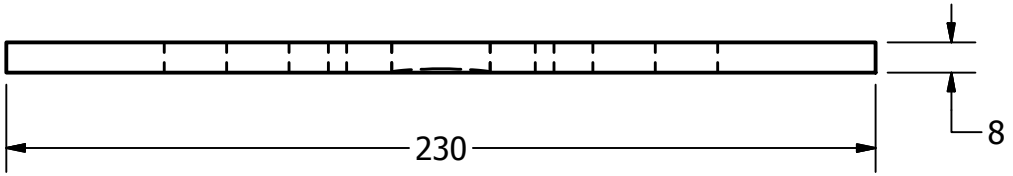

SCALE 1 / 4

SECTION B-B
SCALE 1 / 2

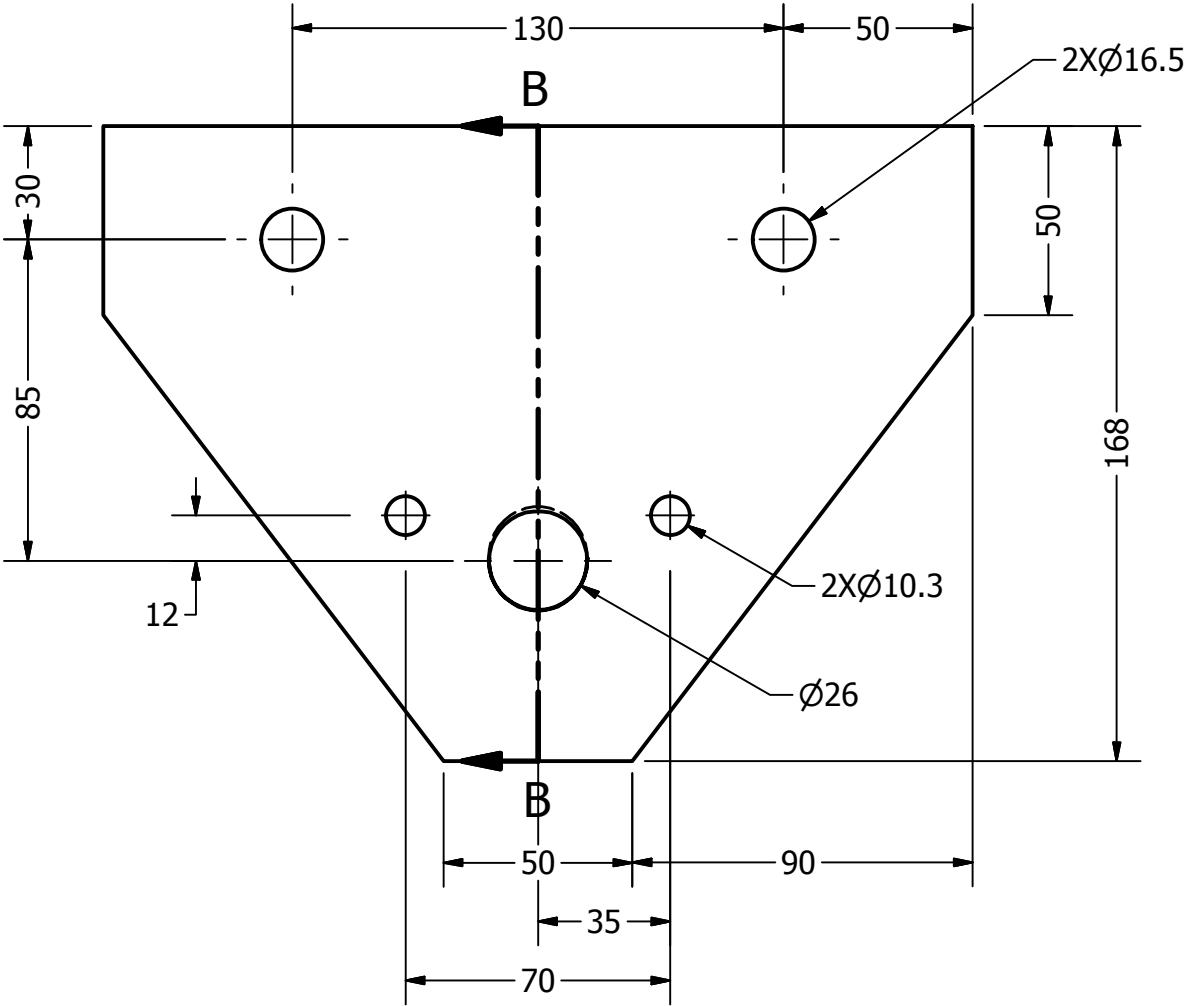
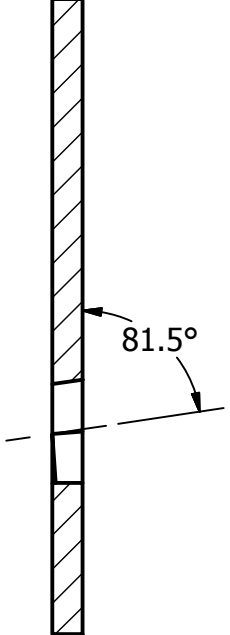

SIDE PLATE
SCALE 1 / 2

DRAWN	ASHLEY JORGENSEN	2/8/2010		
CHECKED			TITLE	
QA			TROLLEY ASSEMBLY	
MFG				
APPROVED				
			SIZE	DWG NO
			B	FIG. 14-83
			SCALE	REV

PARTS LIST			
ITEM	QTY	PART NUMBER	MATERIAL
1	2	PT 2 GUIDE	CI

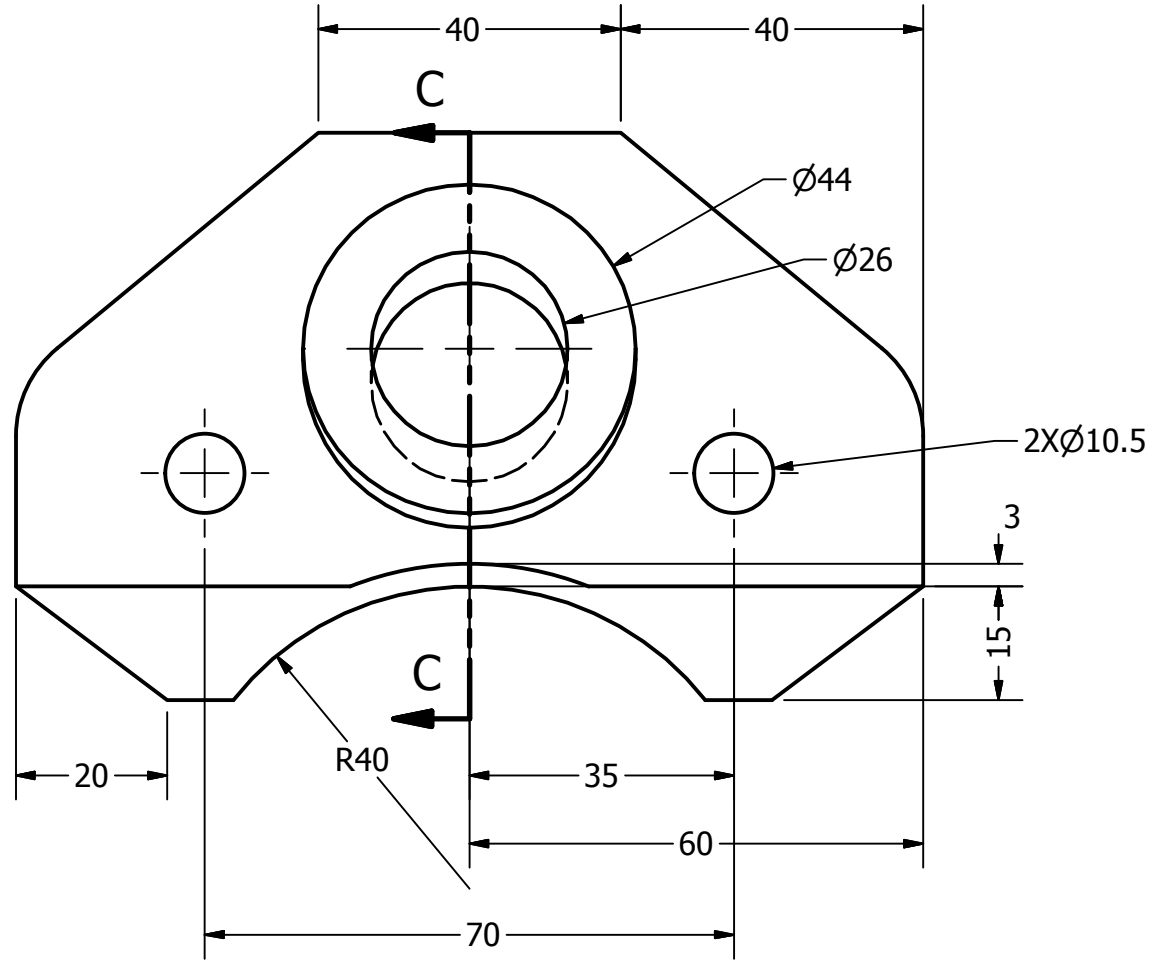
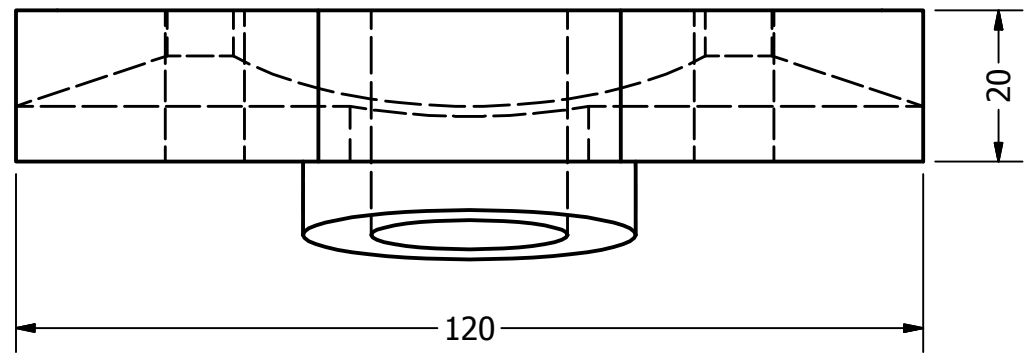
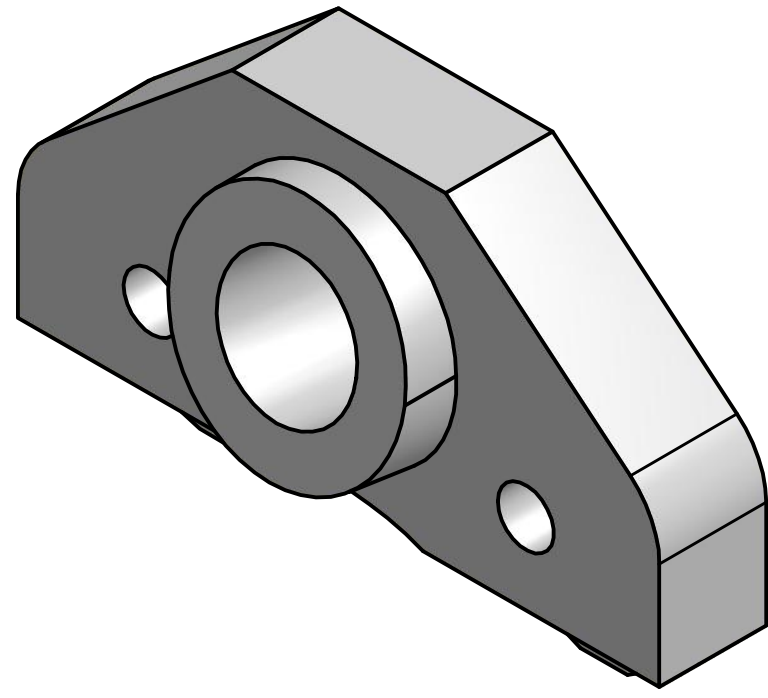

GUIDE
SCALE 1 : 1

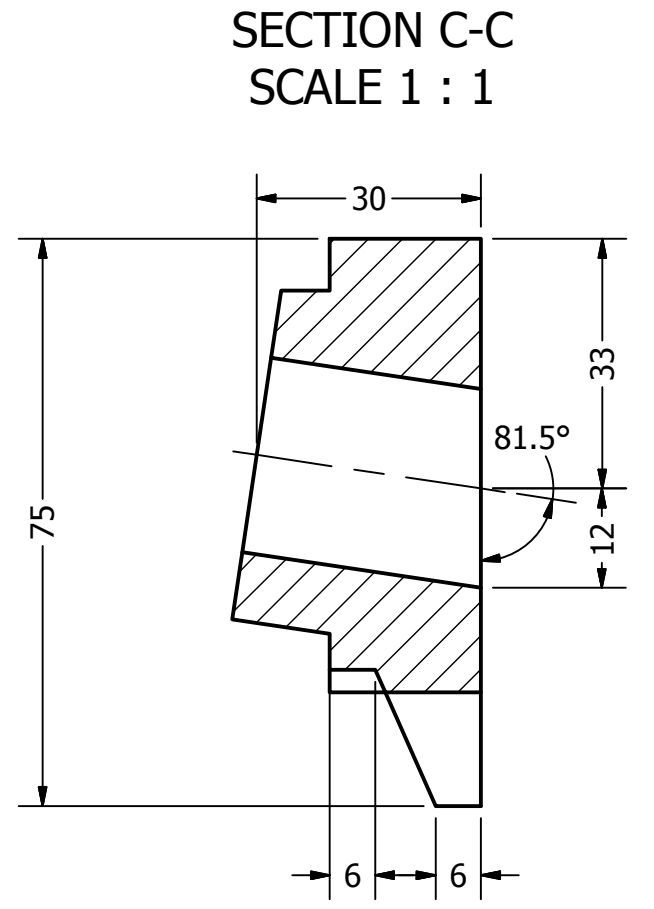

SECTION C-C
SCALE 1 : 1

DRAWN	ASHLEY JORGENSEN	2/8/2010		
CHECKED			TITLE	
QA			TROLLEY ASSEMBLY	
MFG				
APPROVED				
		SIZE	DWG NO	REV
		B	FIG. 14-83	
		SCALE	SHEET 6 OF 10	

PARTS LIST		
ITEM	QTY	PART NUMBER
1	1	PT 3 AXLE

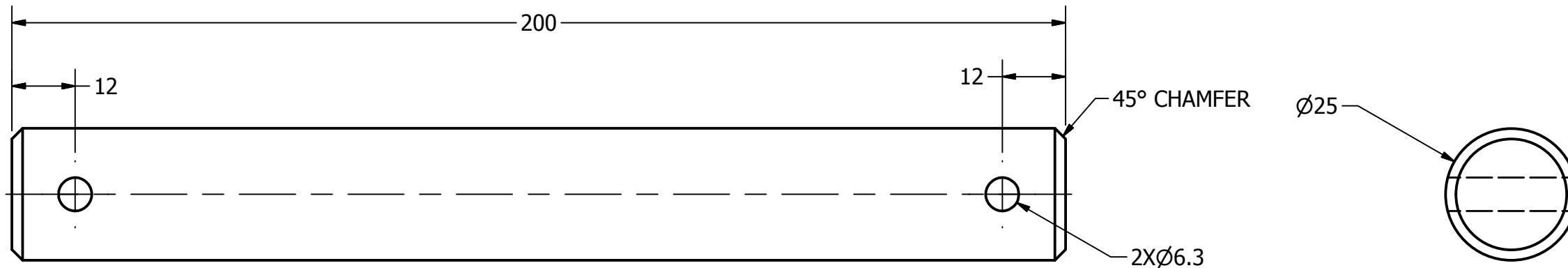
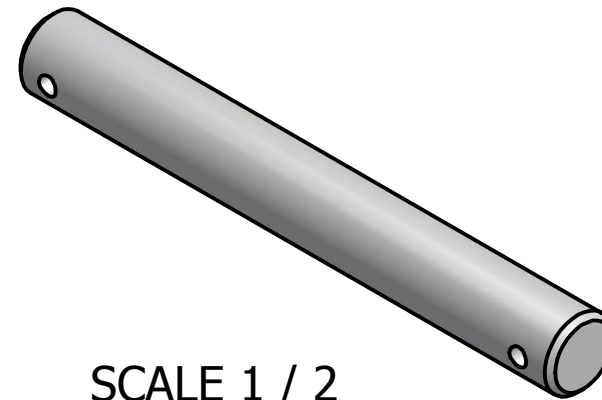

AXLE
SCALE 1 : 1

DRAWN	ASHLEY JORGENSEN	2/8/2010		
CHECKED			TITLE	
QA			TROLLEY ASSEMBLY	
MFG				
APPROVED				
			SIZE	DWG NO
			B	FIG. 14-83
			SCALE	REV
				SHEET 7 OF 10

PARTS LIST		
ITEM	QTY	PART NUMBER
1	1	PT 4 HOOK

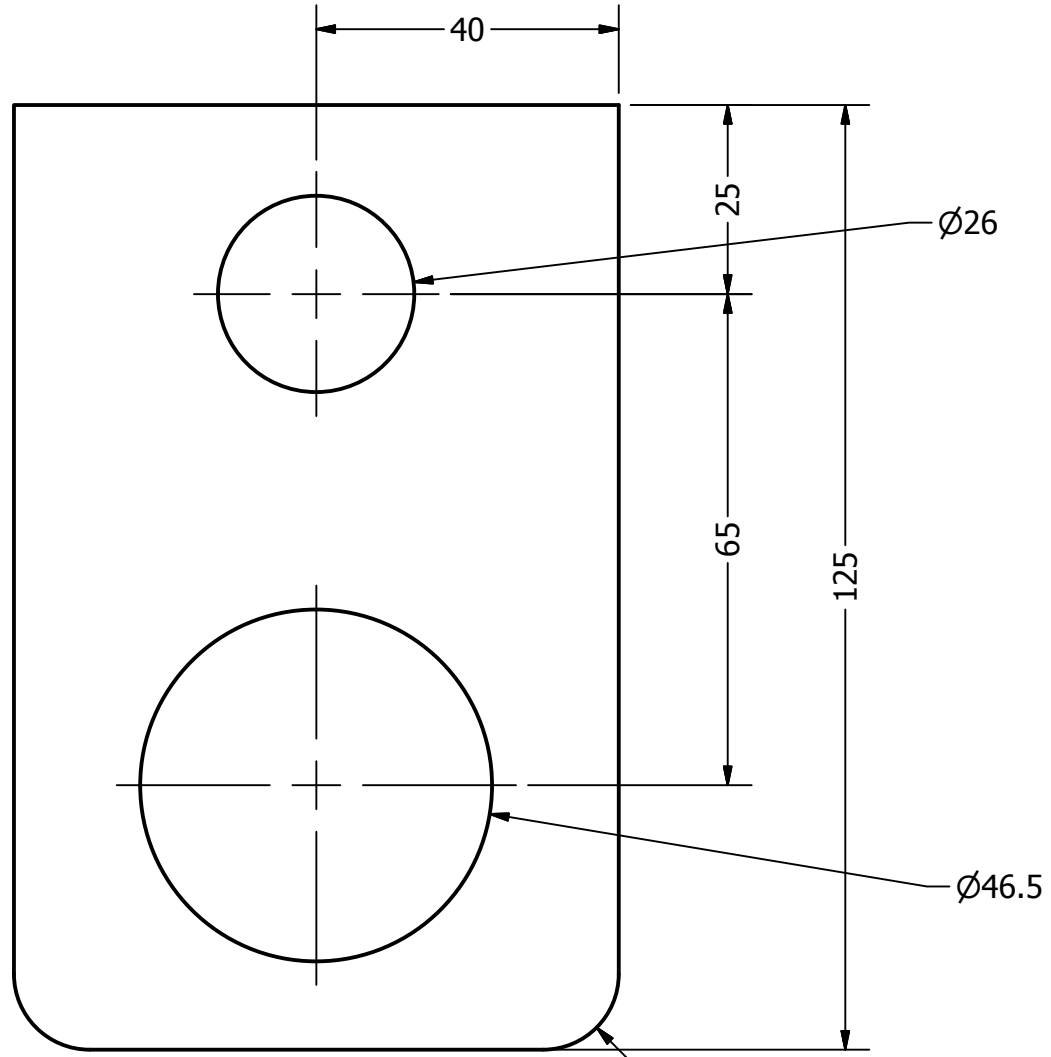
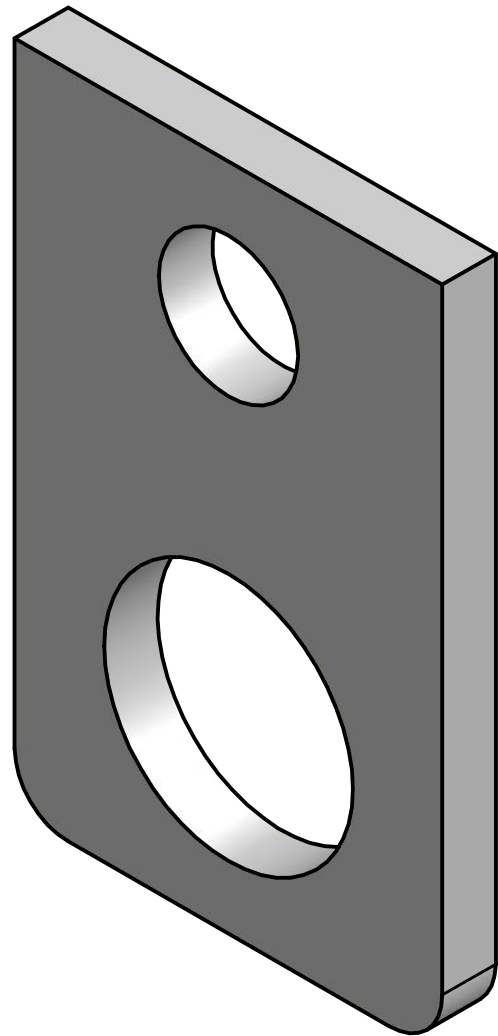
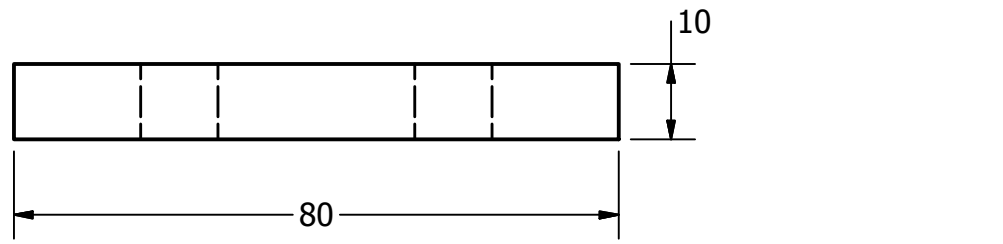

HOOK
SCALE 1 : 1

DRAWN ASHLEY JORGENSEN	2/8/2010	TITLE TROLLEY ASSEMBLY		
CHECKED				
QA		SIZE B	DWG NO FIG. 14-83	REV
MFG		SCALE		
APPROVED		SHEET 8 OF 10		

4

3

2

1

PARTS LIST		
ITEM	QTY	PART NUMBER
1	44	PT 5 ROLLER BEARING

PARTS LIST		
ITEM	QTY	PART NUMBER
1	4	PT 7 AXLE

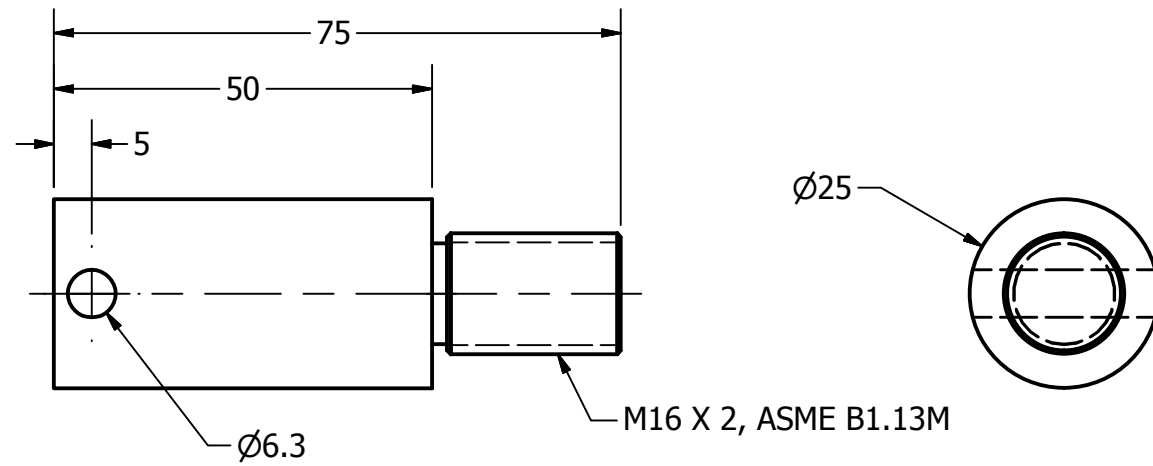
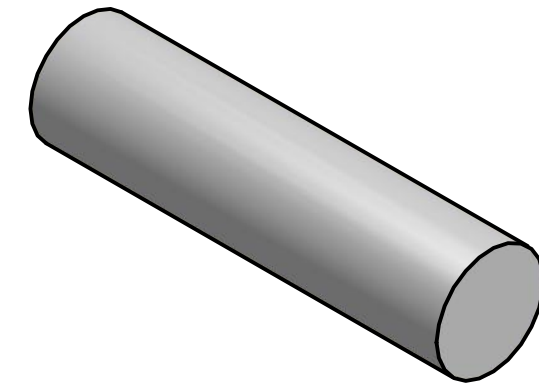
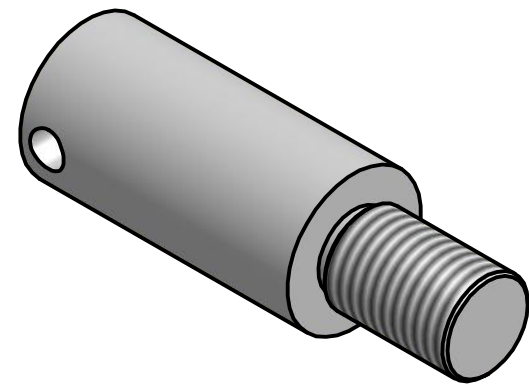

AXLE
SCALE 1 : 1

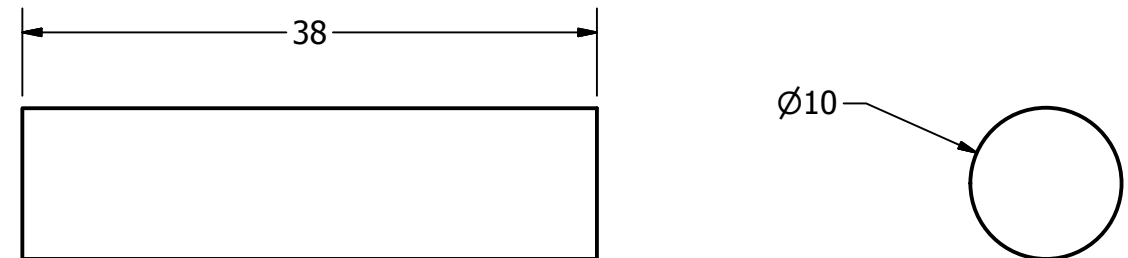

ROLLER BEARING
SCALE 2 : 1

DRAWN	ASHLEY JORGENSEN	2/8/2010		
CHECKED			TITLE	
QA			TROLLEY ASSEMBLY	
MFG			SIZE	DWG NO
APPROVED			B	FIG. 14-83
			SCALE	REV
				SHEET 9 OF 10

4

3

2

1

PARTS LIST		
ITEM	QTY	PART NUMBER
1	4	PT 6 WHEEL

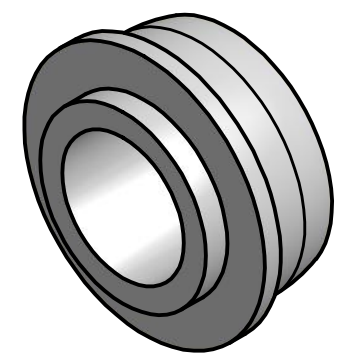

SCALE 1 / 2

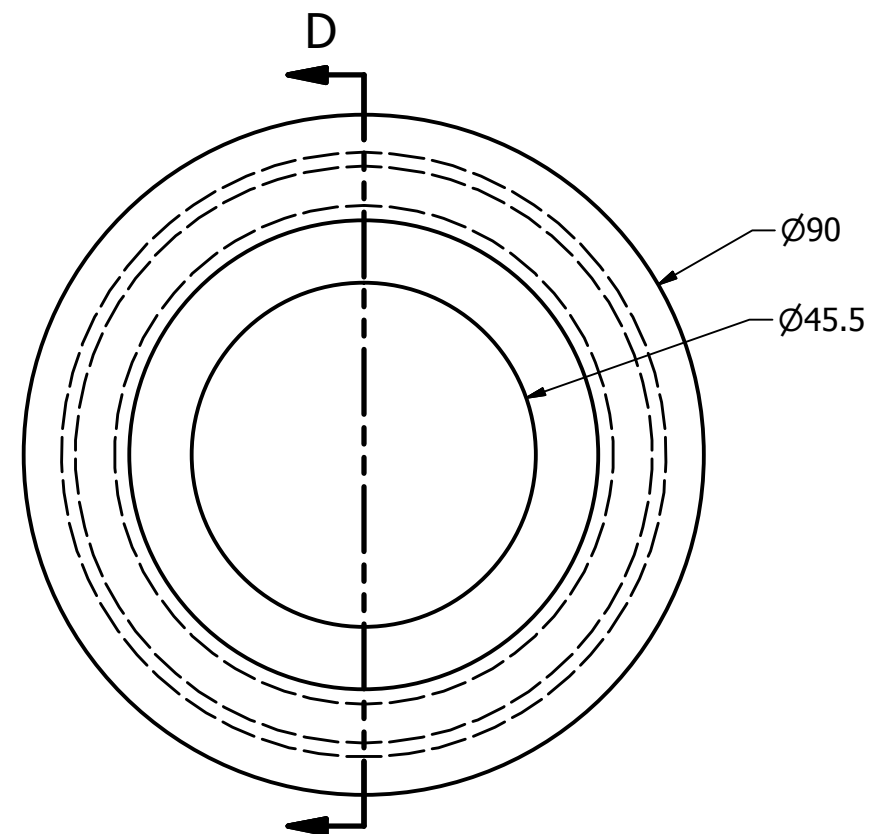

WHEEL
SCALE 1 : 1

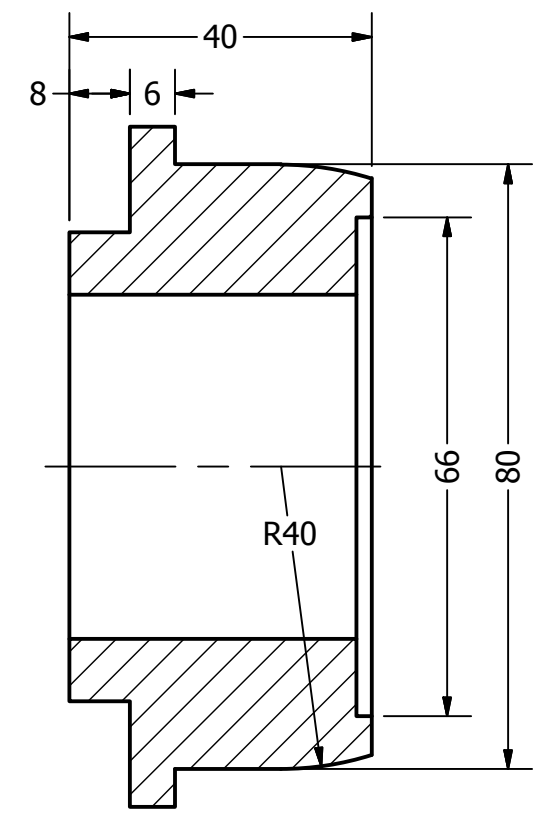

SECTION D-D
SCALE 1 : 1

DRAWN	ASHLEY JORGENSEN	2/8/2010		
CHECKED			TITLE	
QA			TROLLEY ASSEMBLY	
MFG				
APPROVED				
			SIZE	DWG NO
			B	FIG. 14-83
			SCALE	REV
			SHEET 10 OF 10	