

PARTS LIST			
ITEM	QTY	PART NUMBER	MATERIAL
1	1	BASE	ANSI 1040 STL
2	1	CORNER	ANSI 1040 STL
3	1	CYLINDER	ANSI 1040 STL

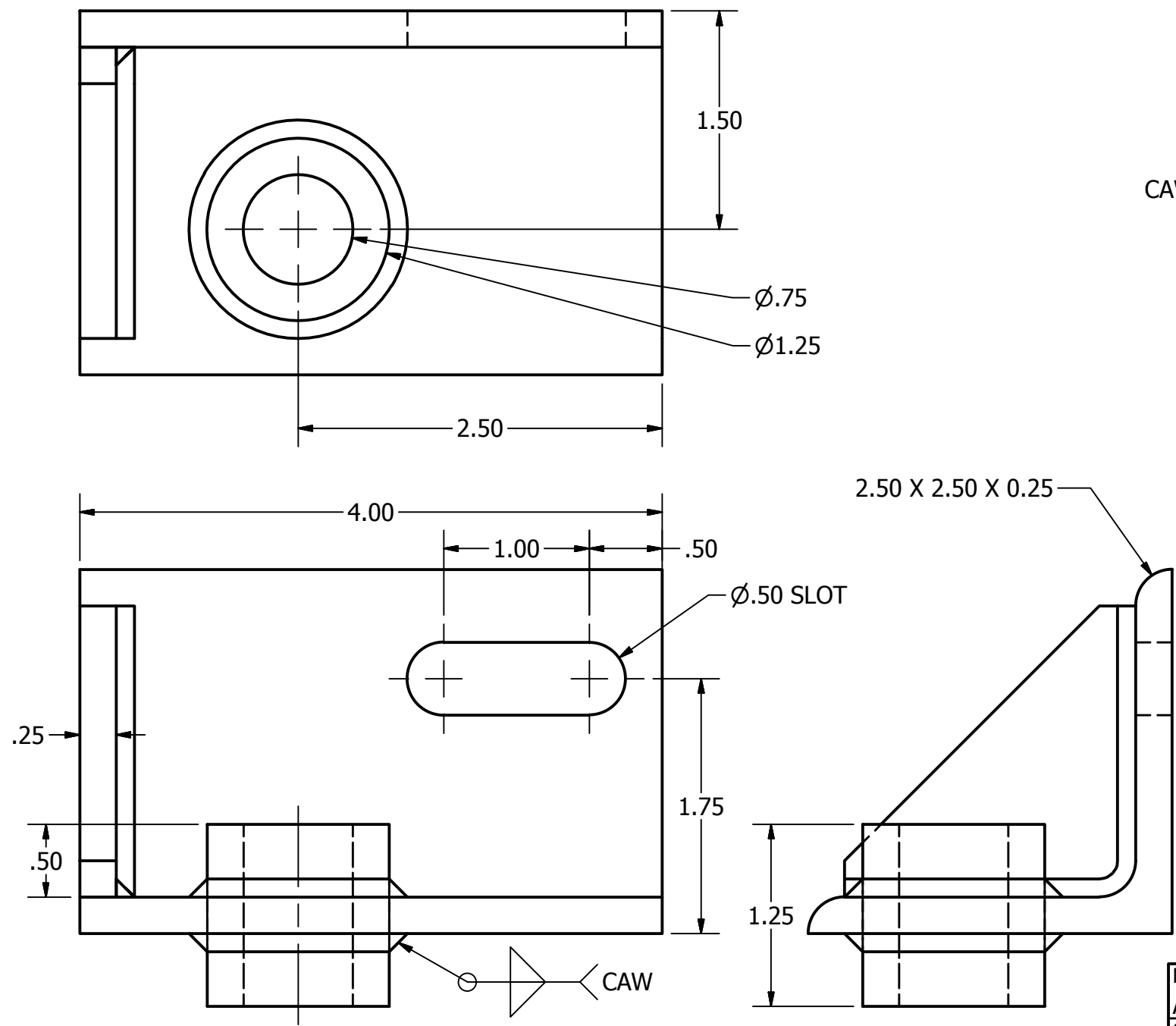
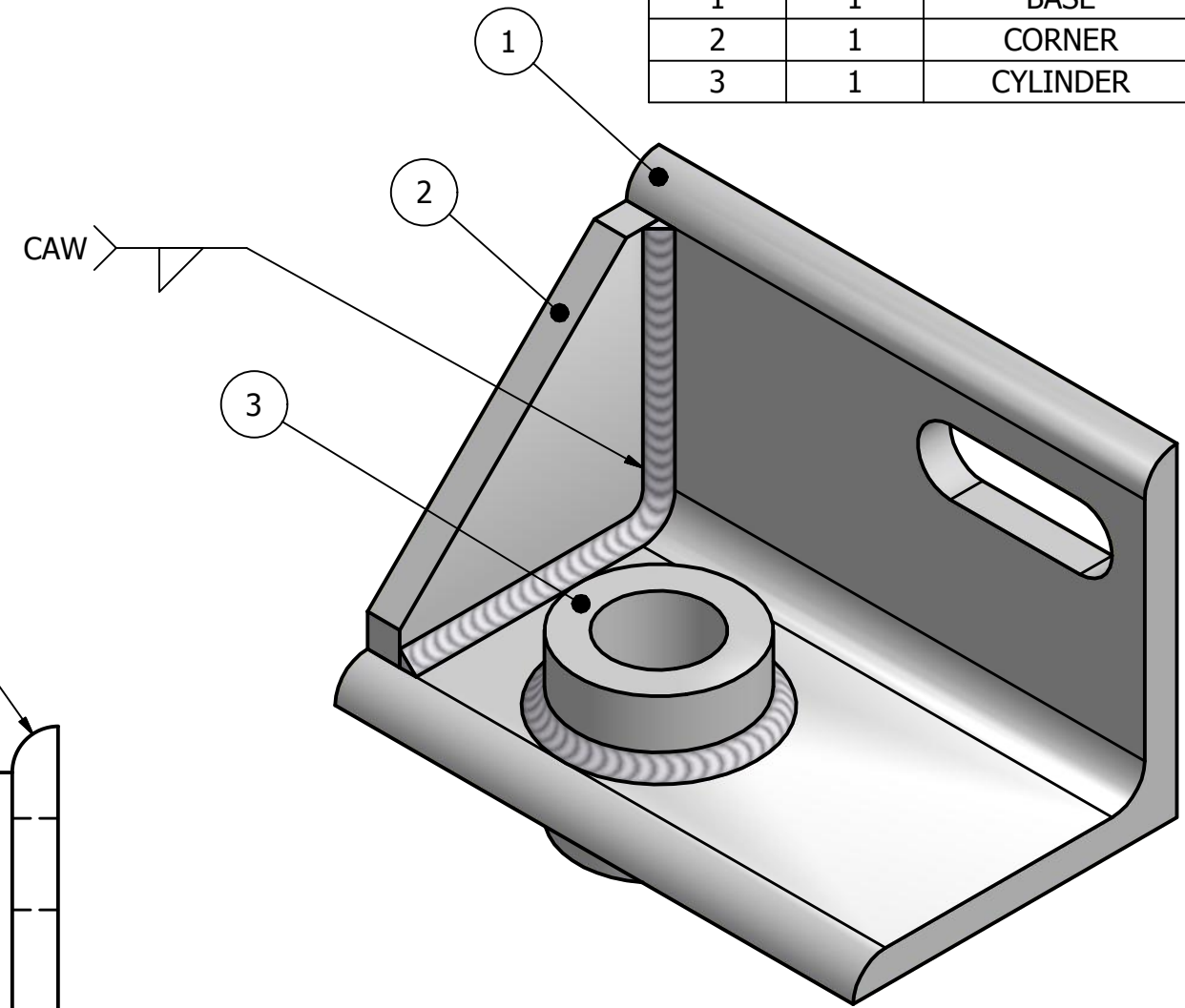

FIG 18-43 SLIDE BRACKET
SCALE 1 : 1

DRAWN	ASHLEY JORGENSEN	4/20/2010	TITLE	
CHECKED			FIG 18-43 SLIDE BRACKET	
QA			SIZE	DWG NO
MFG			B	FIG 18-43 ASSEMBLY
APPROVED			SCALE	REV
				SHEET 1 OF 1