

PARTS LIST		
ITEM	QTY	PART NUMBER
1	4	SPRING ASSEMBLY
2	1	FRAME WELDMENT

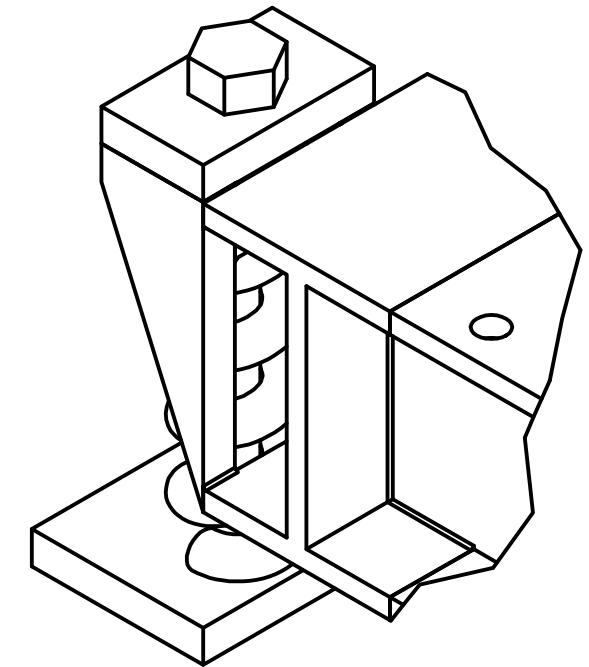
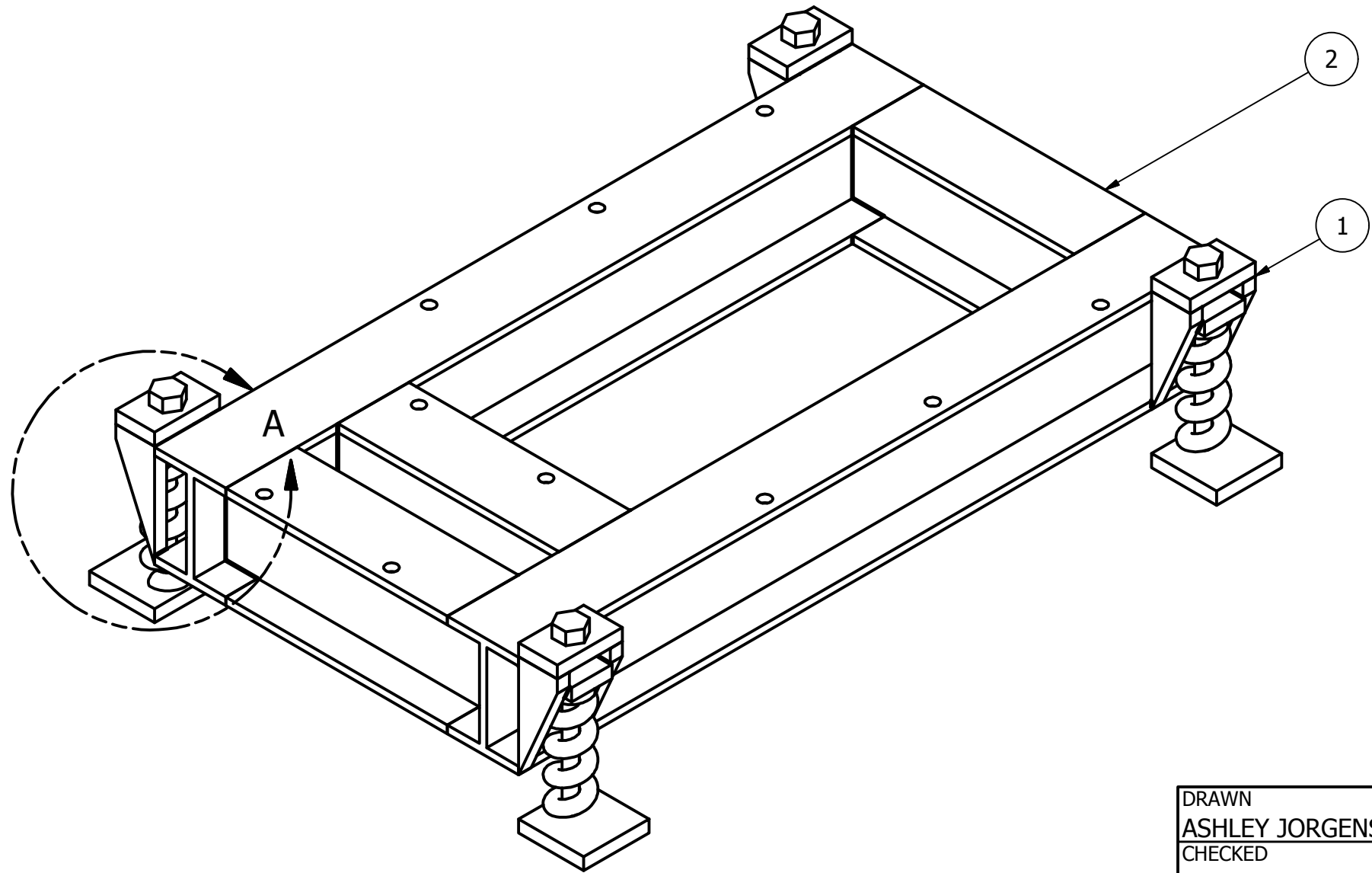

DETAIL A
SCALE 1 / 2

FAN AND MOTOR BASE
SCALE 1 / 4

ALL WELDS ARE 1 mm UNLESS OTHERWISE NOTED.

DRAWN	ASHLEY JORGENSEN	2/22/2010		
CHECKED				
QA			TITLE	
MFG			FAN AND MOTOR BASE	
APPROVED				
			SIZE	DWG NO
			B	FAN AND MOTOR BASE
			SCALE	REV
				SHEET 1 OF 5

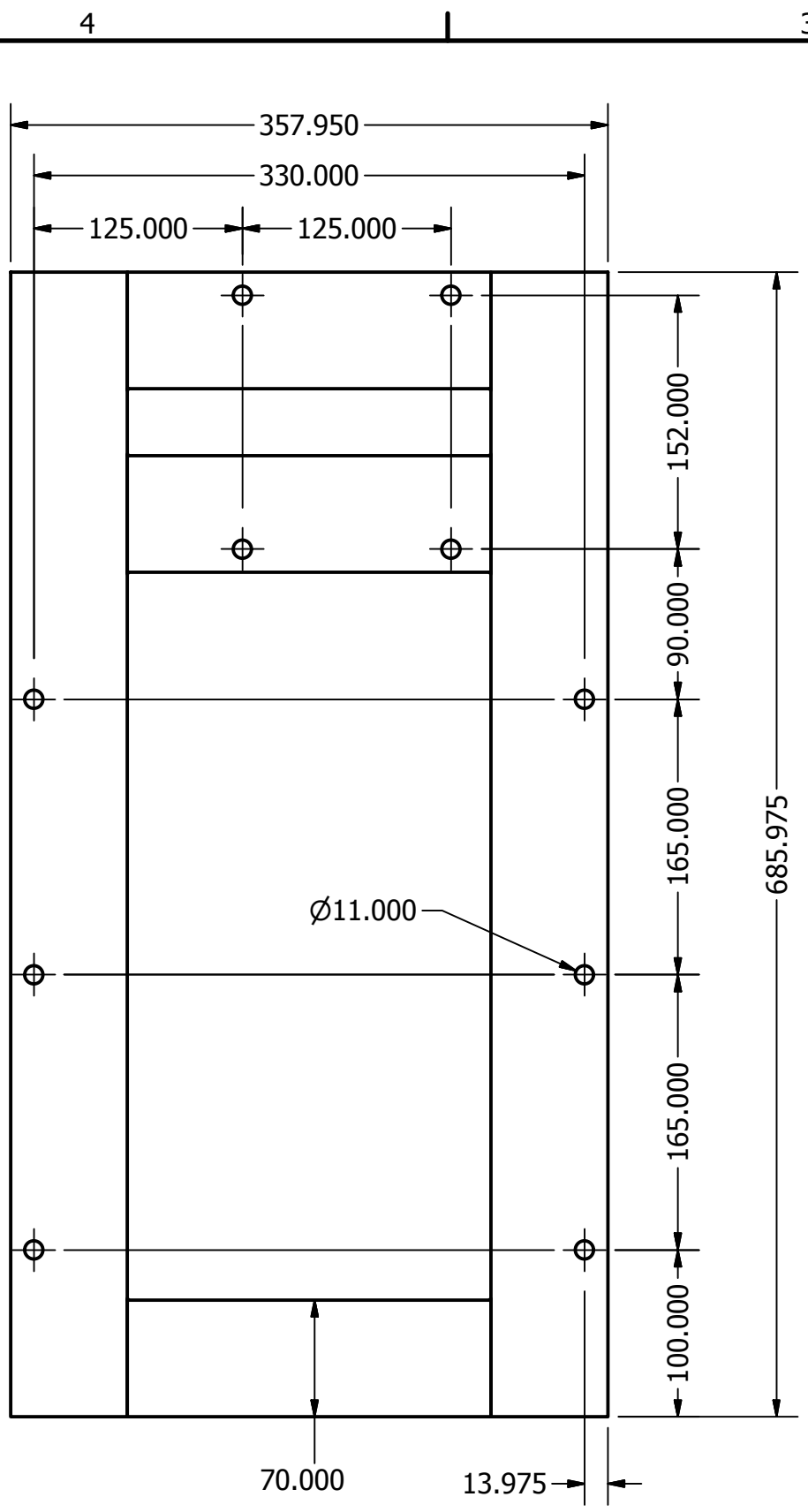

FRAME ASSEMBLY
SCALE 1 / 4

PARTS LIST			
ITEM	QTY	PART NUMBER	DESCRIPTION
1	1	BEAM1	S 100 X 14.1
2	1	BEAM2	S 100 X 14.1
3	1	BEAM3	S 100 X 14.1
4	1	BEAM4	S 100 X 14.1
5	1	BEAM5	S 100 X 14.1

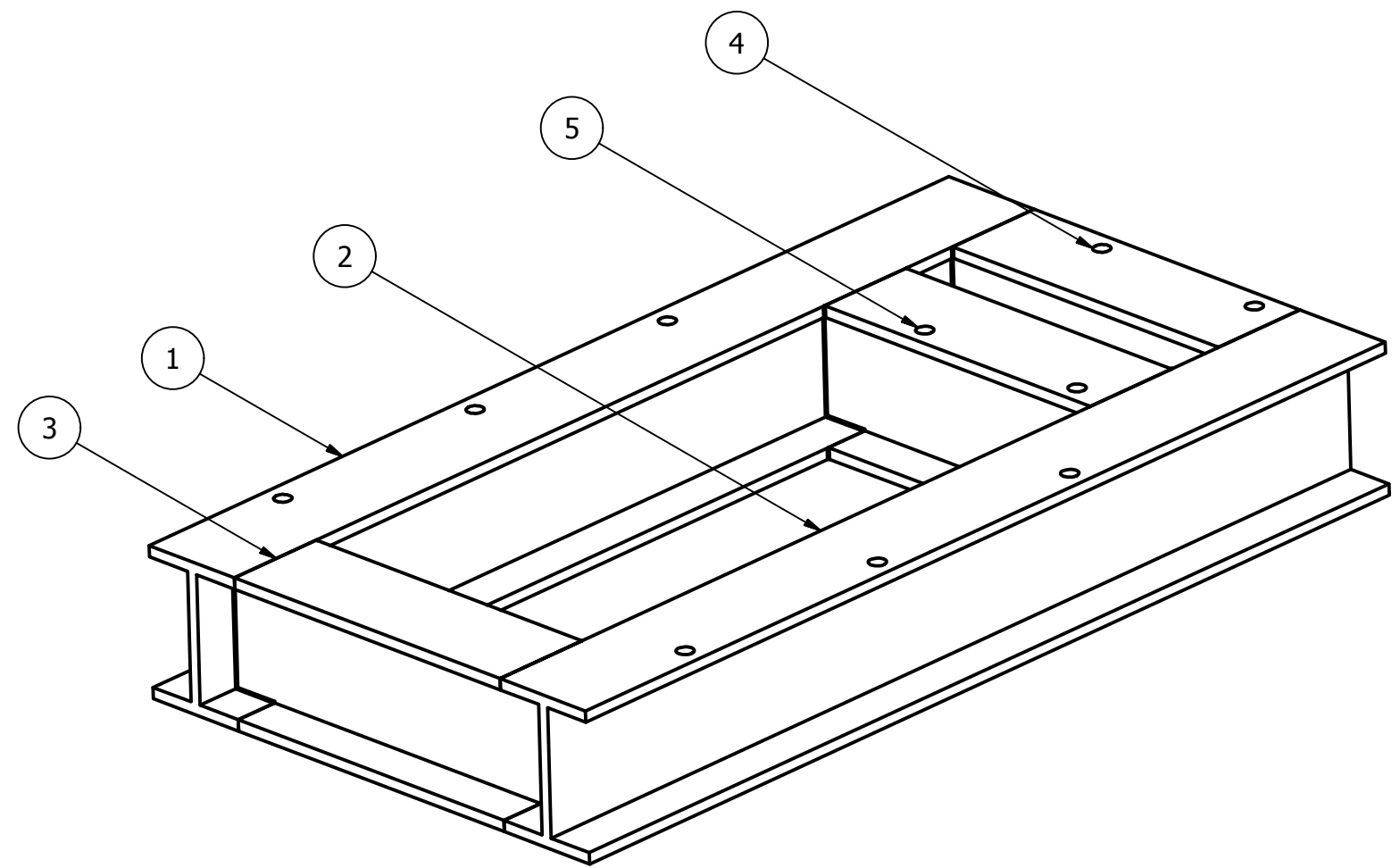

DRAWN ASHLEY JORGENSEN	2/22/2010	TITLE	
CHECKED		FAN AND MOTOR BASE	
QA		SIZE B	DWG NO
MFG		FAN AND MOTOR BASE	
APPROVED		SCALE	REV
		SHEET 2 OF 5	

PARTS LIST		
ITEM	QTY	PART NUMBER
1	2	TRIANGLE PLATE
2	1	TOP PLATE
3	1	BOLT
4	1	INSIDE PLATE
5	1	BOTTOM PLATE
6	1	SPRING

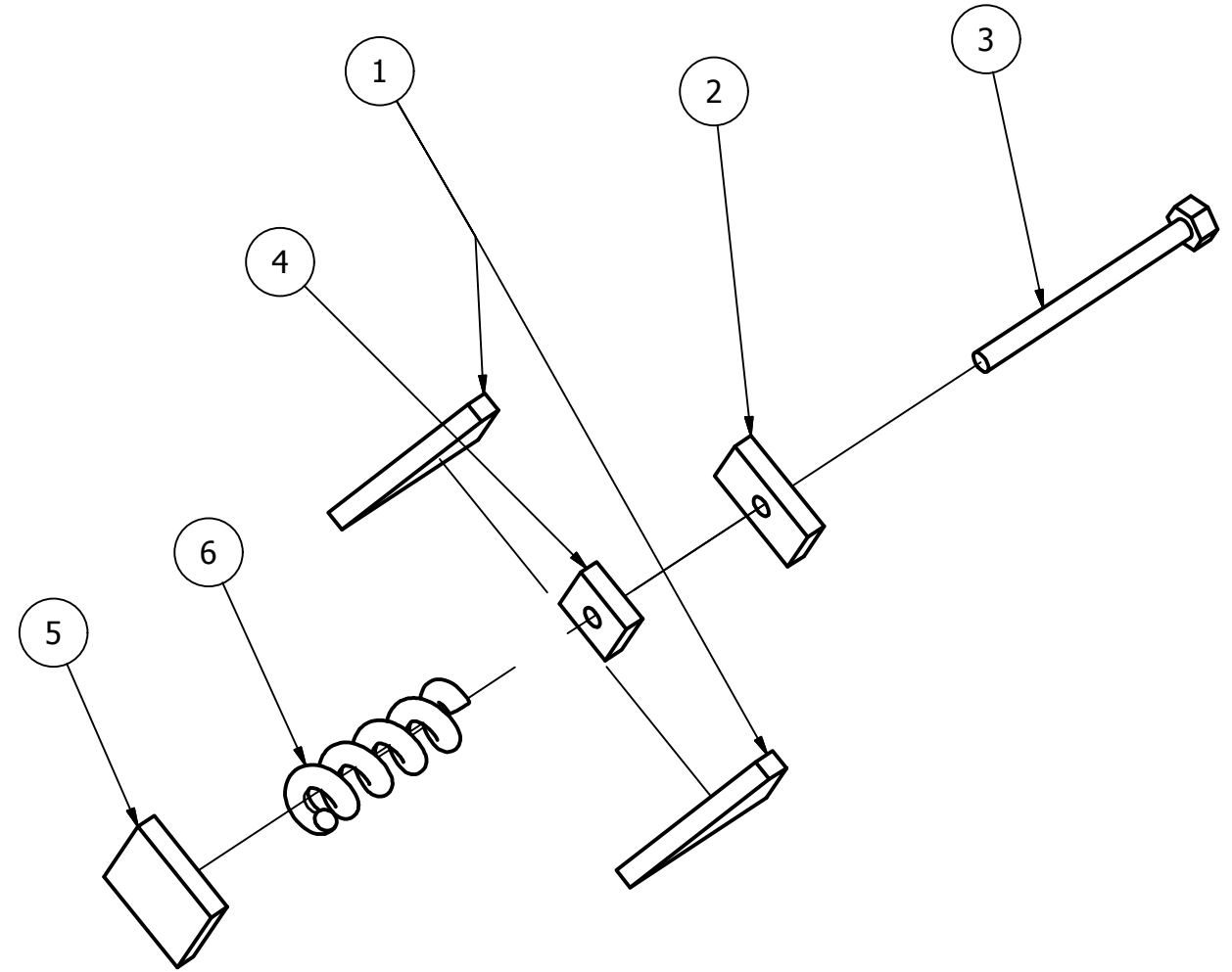

SPRING ASSEMBLY
SCALE 1 / 4

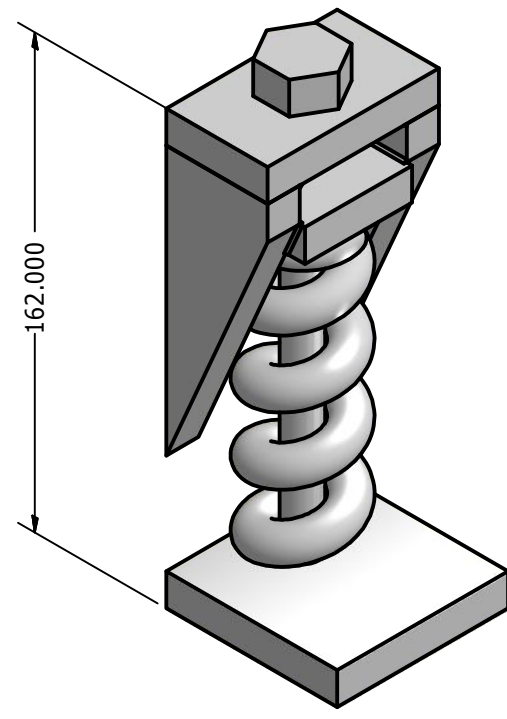

SPRING
SCALE 1 / 2

DRAWN	ASHLEY JORGENSEN	2/22/2010		
CHECKED				
QA			TITLE	
MFG			FAN AND MOTOR BASE	
APPROVED				
		SIZE	DWG NO	REV
		B	FAN AND MOTOR BASE	
		SCALE	SHEET 3 OF 5	

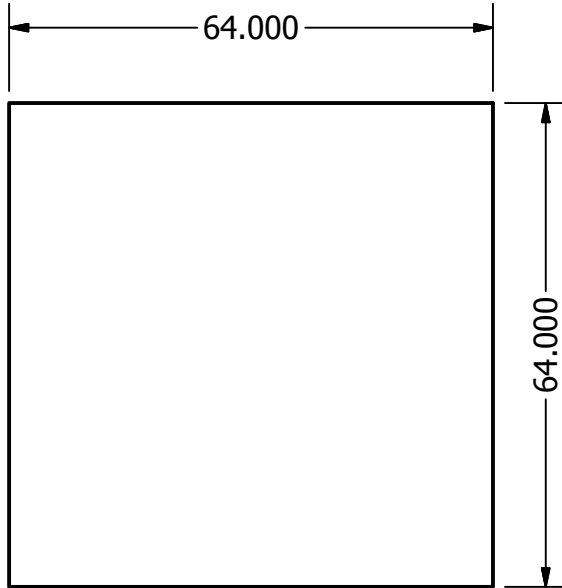
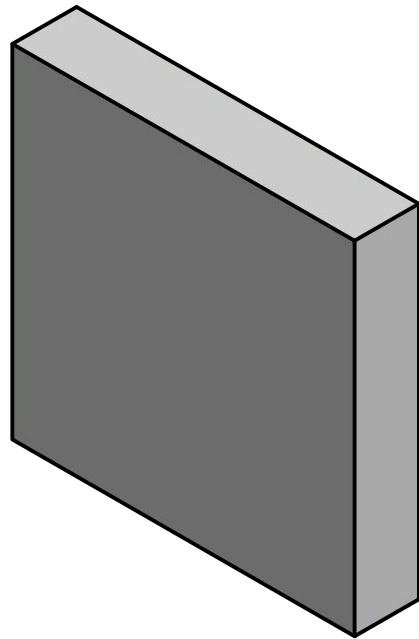
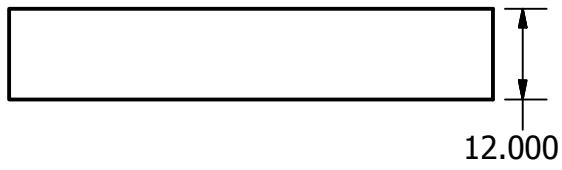

BOTTOM PLATE
SCALE 1 : 1

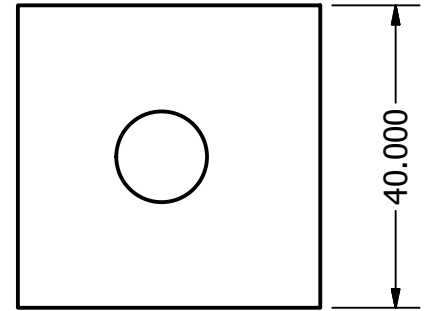
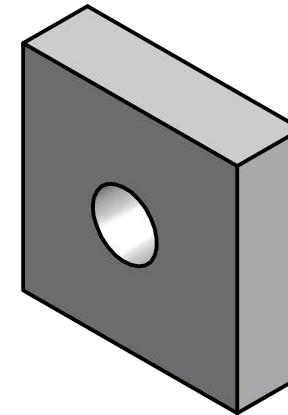
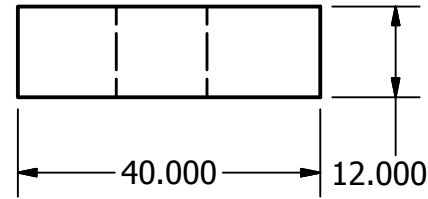

INSIDE PLATE
SCALE 1 : 1

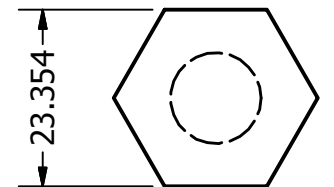
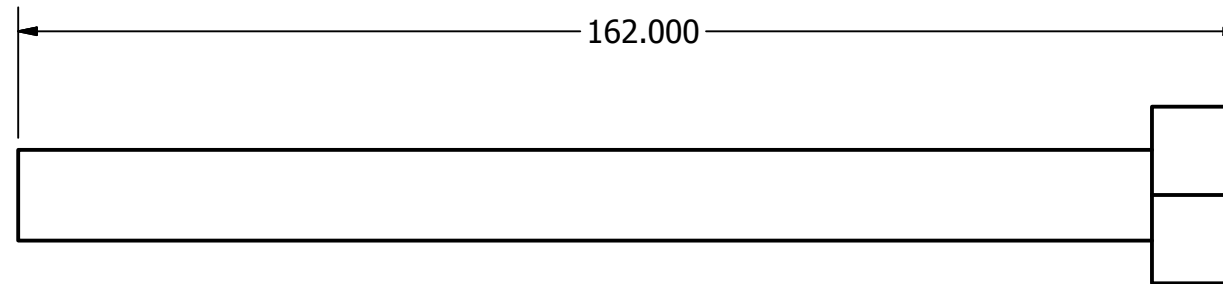

BOLT
SCALE 1 : 1

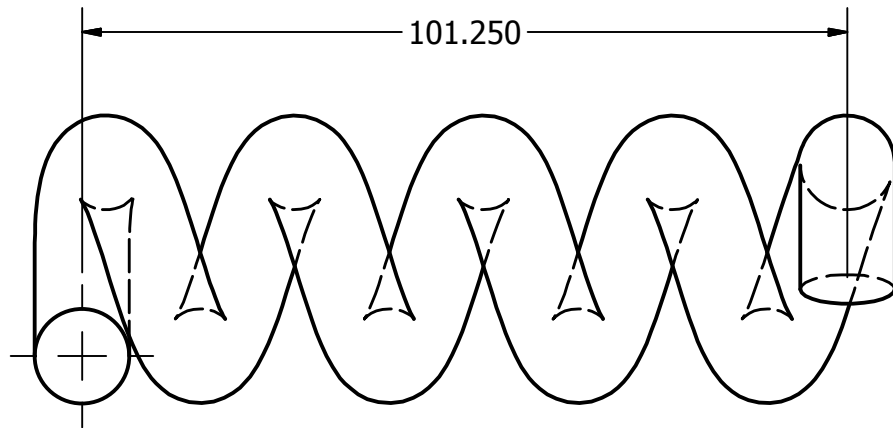
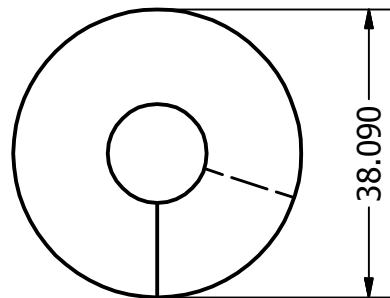

SPRING
SCALE 1 : 1

PARTS LIST		
ITEM	QTY	PART NUMBER
1	1	SPRING
PARTS LIST		
ITEM	QTY	PART NUMBER
1	1	BOLT
PARTS LIST		
ITEM	QTY	PART NUMBER
1	1	INSIDE PLATE
PARTS LIST		
ITEM	QTY	PART NUMBER
1	1	BOTTOM PLATE

DRAWN ASHLEY JORGENSEN	2/22/2010	TITLE FAN AND MOTOR BASE		
CHECKED				
QA				
MFG				
APPROVED		SIZE B	DWG NO FAN AND MOTOR BASE	REV
		SCALE	SHEET 4 OF 5	

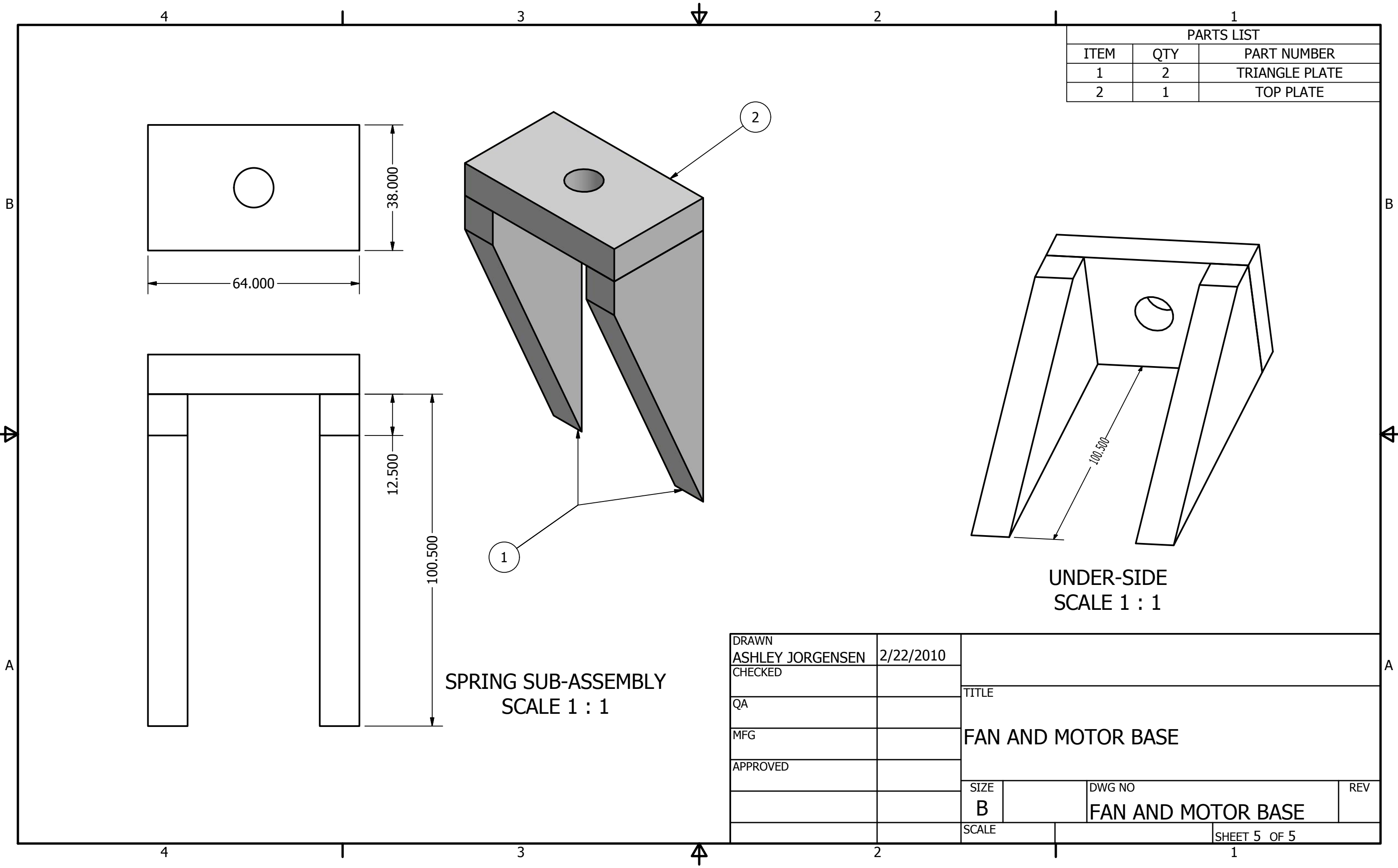

PARTS LIST		
ITEM	QTY	PART NUMBER
1	2	TRIANGLE PLATE
2	1	TOP PLATE

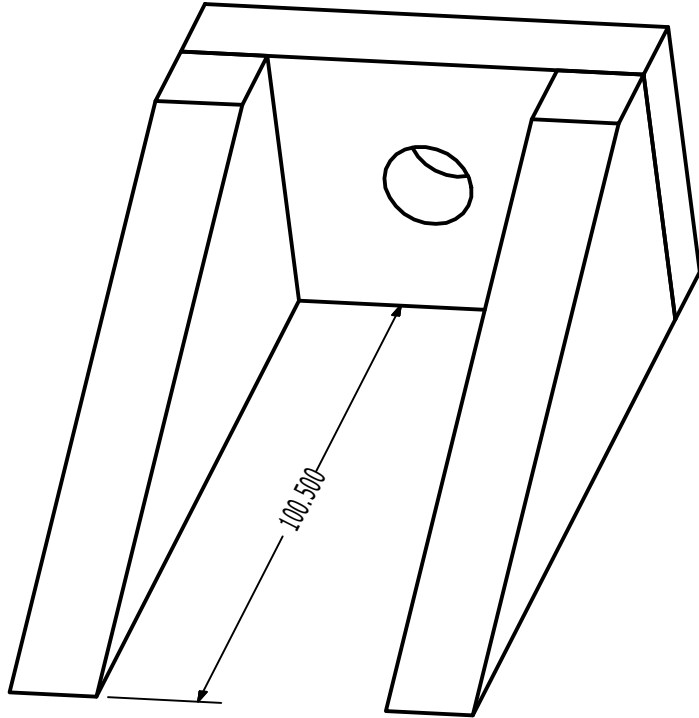
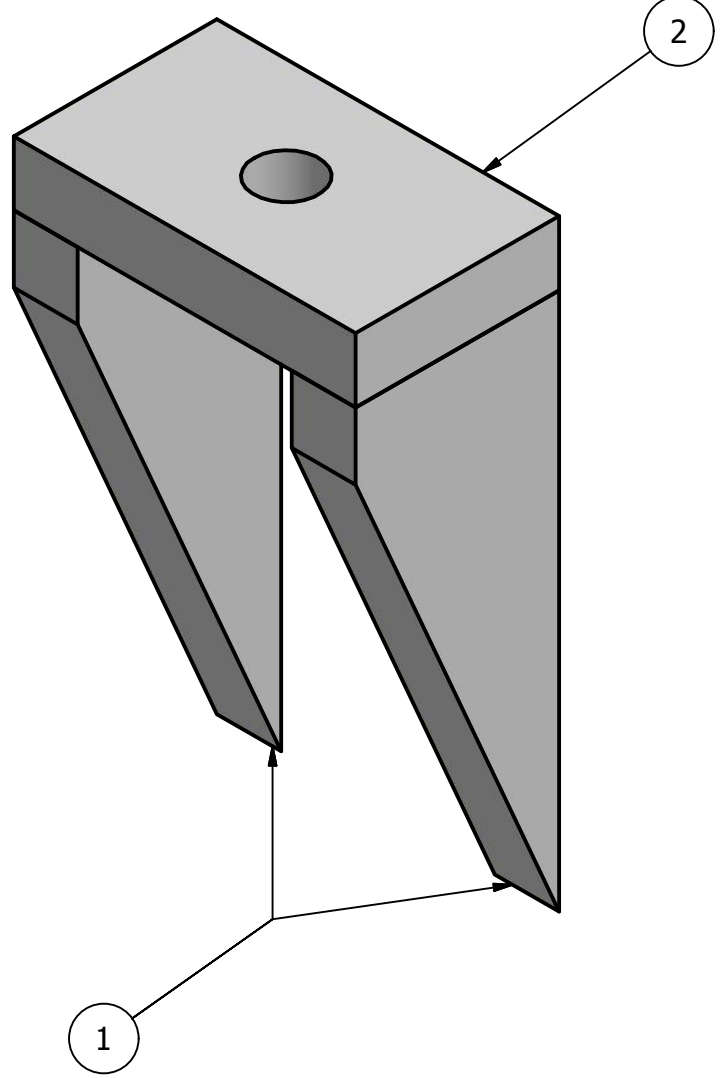
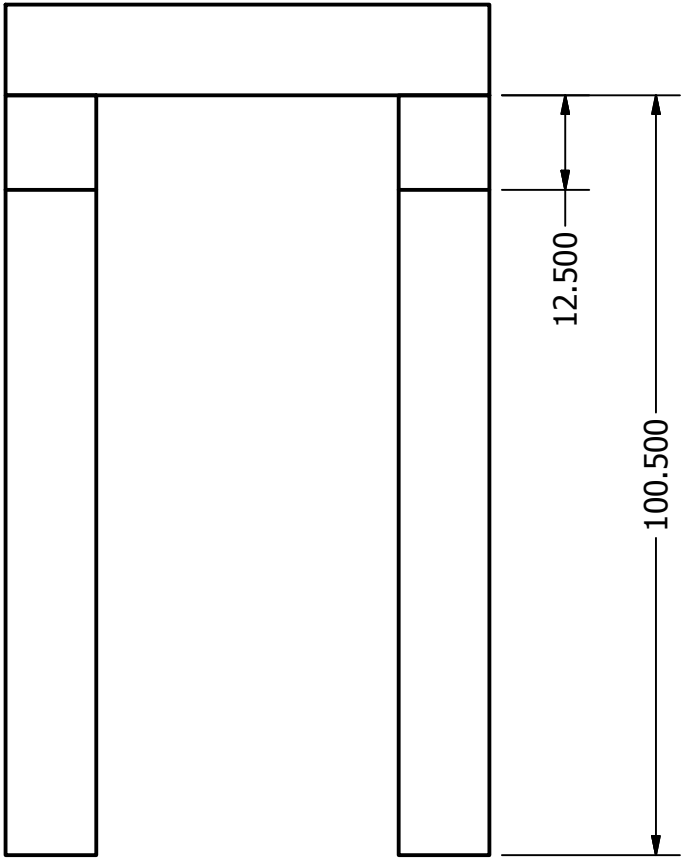
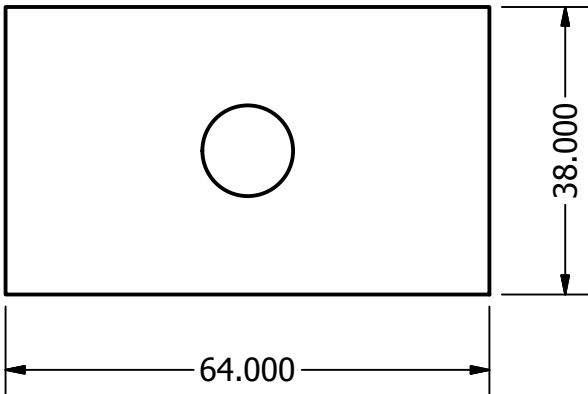

UNDER-SIDE
SCALE 1 : 1

SPRING SUB-ASSEMBLY
SCALE 1 : 1

DRAWN	ASHLEY JORGENSEN	2/22/2010		
CHECKED				
QA			TITLE	
MFG			FAN AND MOTOR BASE	
APPROVED				
		SIZE	DWG NO	REV
		B	FAN AND MOTOR BASE	
		SCALE	SHEET 5 OF 5	