

4

3

2

1

PARTS LIST			
ITEM	QTY	PART NUMBER	DESCRIPTION
1	1		TOP PLATE
2	2		AXLE SUPPORT
3	2		BUSHING
4	1		AXLE
5	1		WHEEL

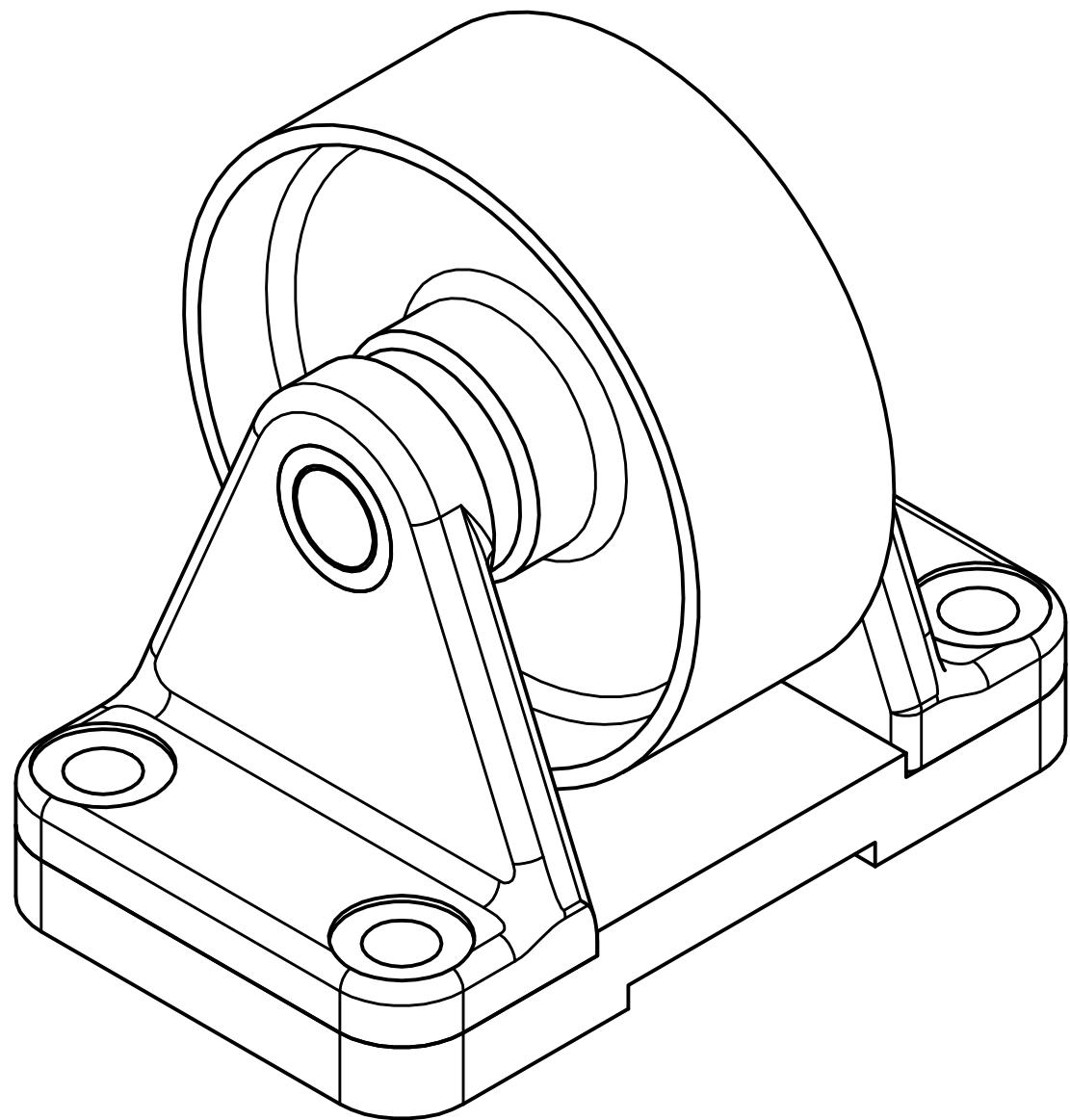

CASTER ASSEMBLY  
SCALE 1 : 1

DRAWN	ASHLEY JORGENSEN	1/26/2010		
CHECKED				
QA			TITLE	
MFG			CASTER ASSEMBLY	
APPROVED				
		SIZE	DWG NO	REV
		<b>B</b>	<b>FIG. 9-51</b>	
		SCALE	SHEET 1 OF 7	

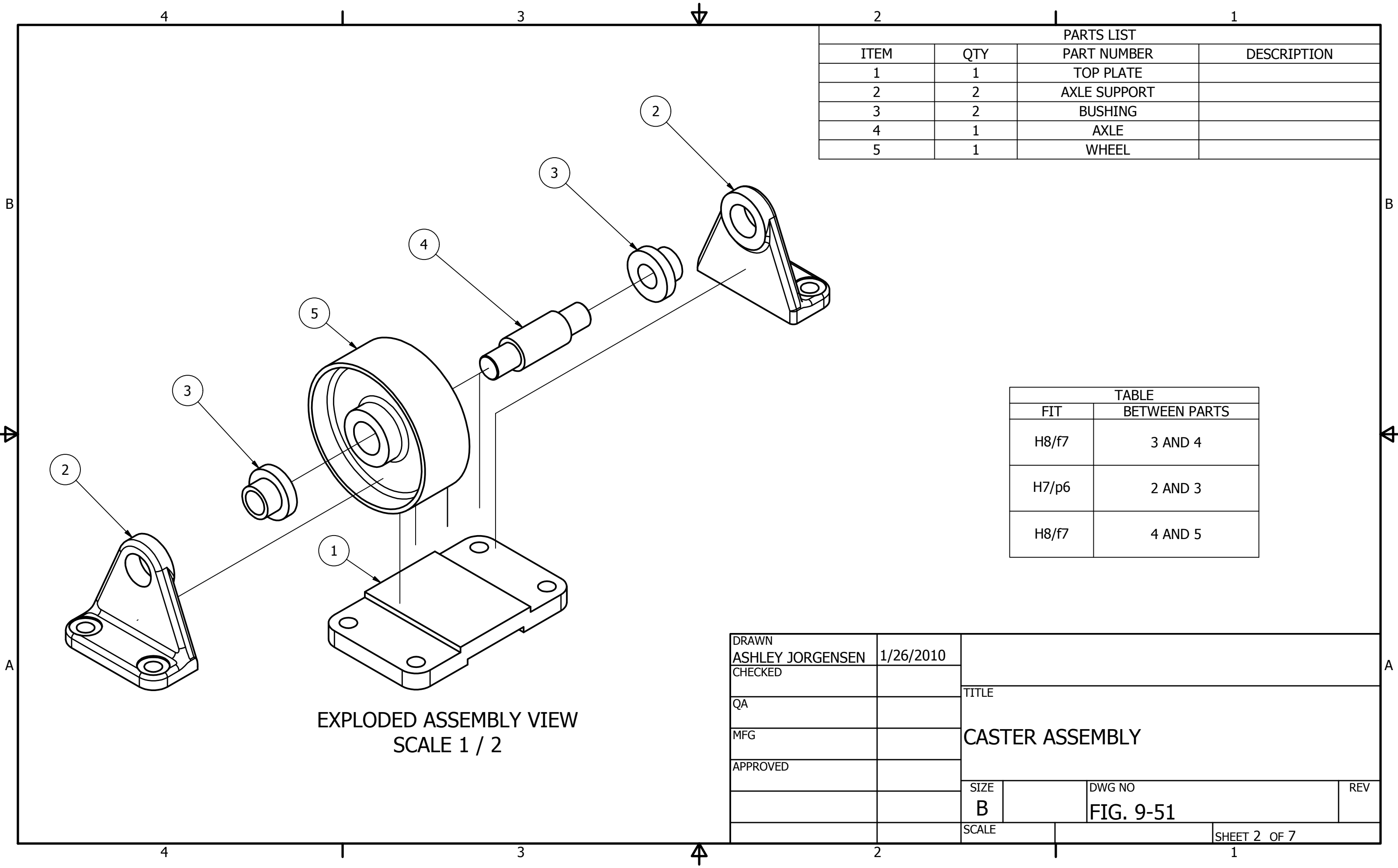

PARTS LIST			
ITEM	QTY	PART NUMBER	DESCRIPTION
1	1		TOP PLATE
2	2		AXLE SUPPORT
3	2		BUSHING
4	1		AXLE
5	1		WHEEL

TABLE	
FIT	BETWEEN PARTS
H8/f7	3 AND 4
H7/p6	2 AND 3
H8/f7	4 AND 5

EXPLODED ASSEMBLY VIEW  
SCALE 1 / 2

DRAWN	ASHLEY JORGENSEN	1/26/2010		
CHECKED			TITLE	
QA			CASTER ASSEMBLY	
MFG				
APPROVED				
		SIZE	DWG NO	REV
		B	FIG. 9-51	
		SCALE	SHEET 2 OF 7	

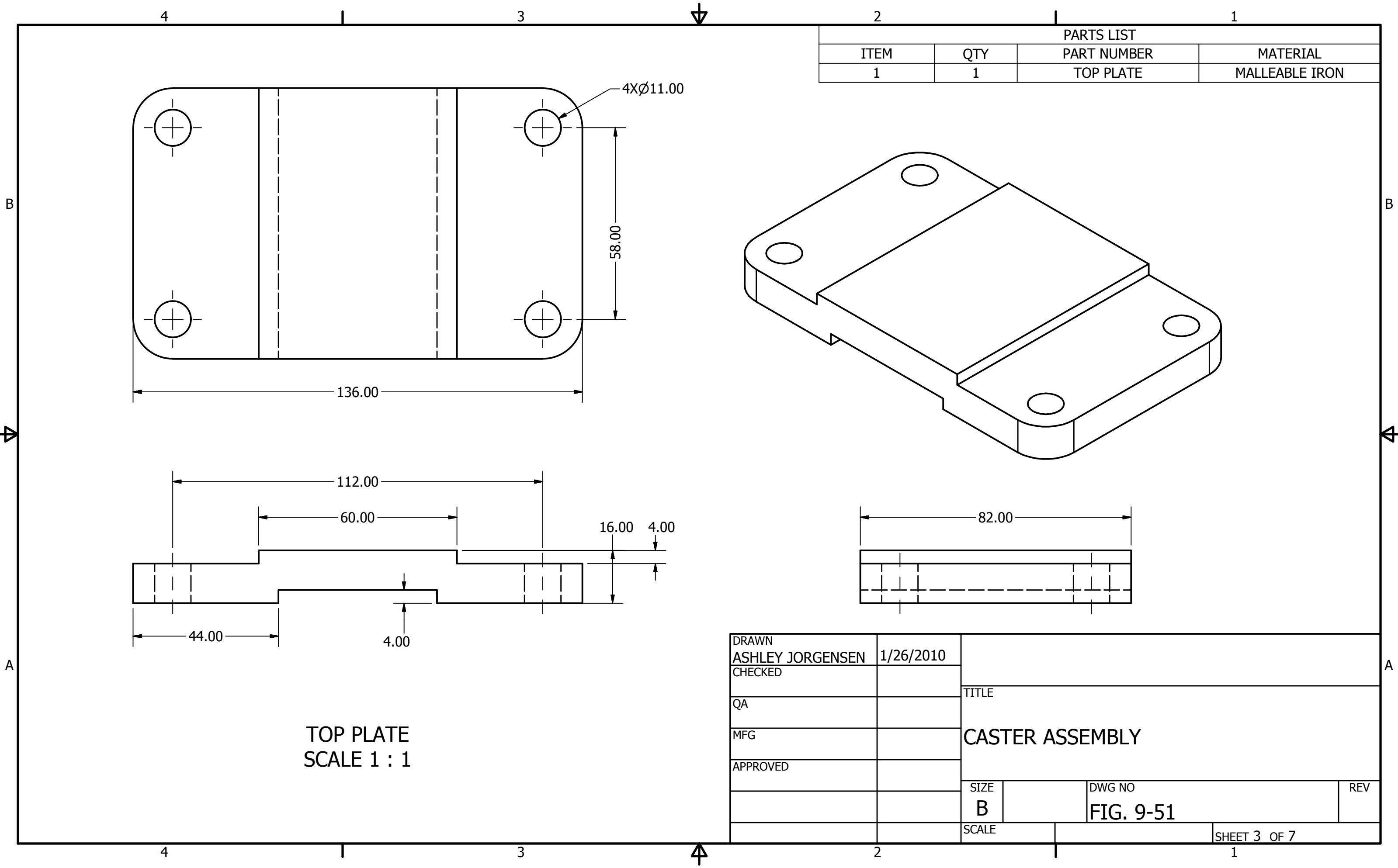

PARTS LIST			
ITEM	QTY	PART NUMBER	MATERIAL
1	1	TOP PLATE	MALLEABLE IRON

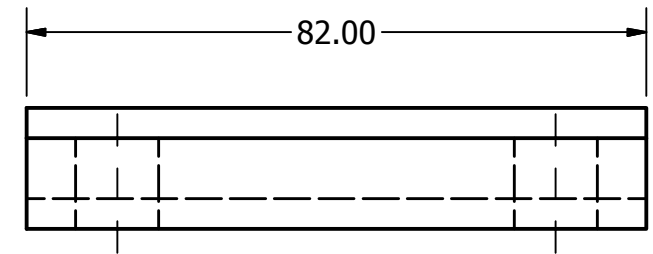
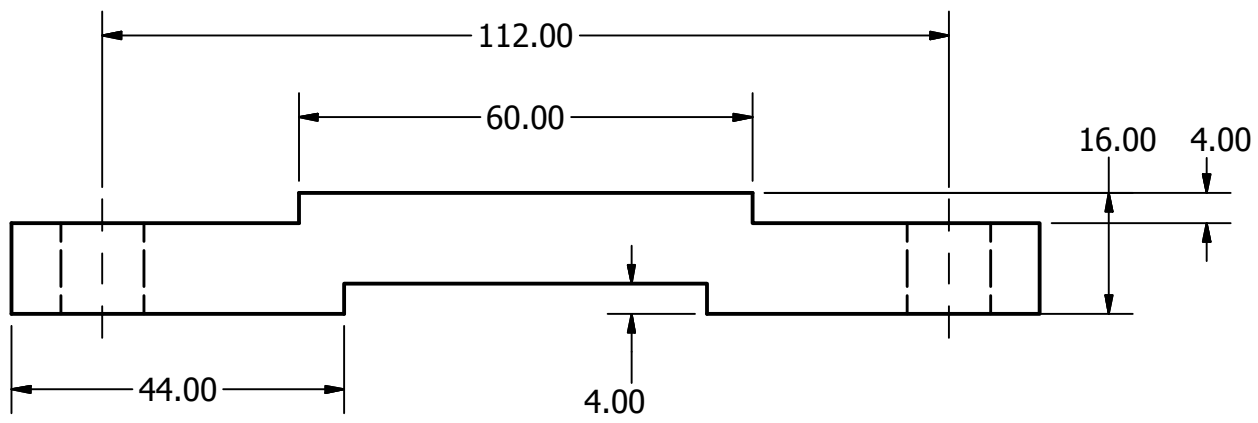

TOP PLATE  
SCALE 1 : 1

DRAWN	ASHLEY JORGENSEN	1/26/2010	TITLE	
CHECKED			CASTER ASSEMBLY	
QA			SIZE	DWG NO
MFG			B	FIG. 9-51
APPROVED			SCALE	REV

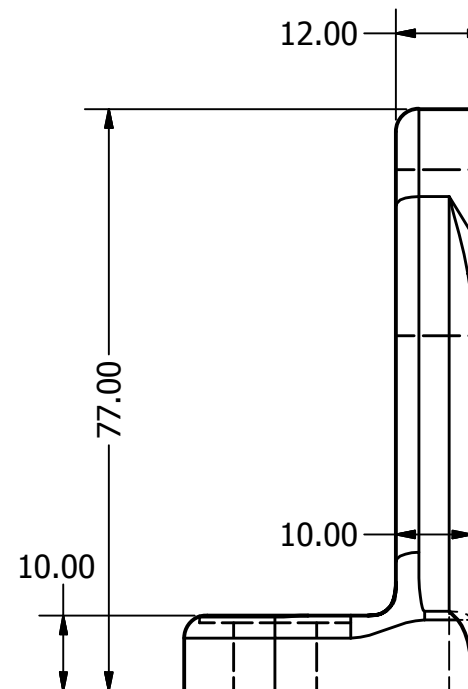
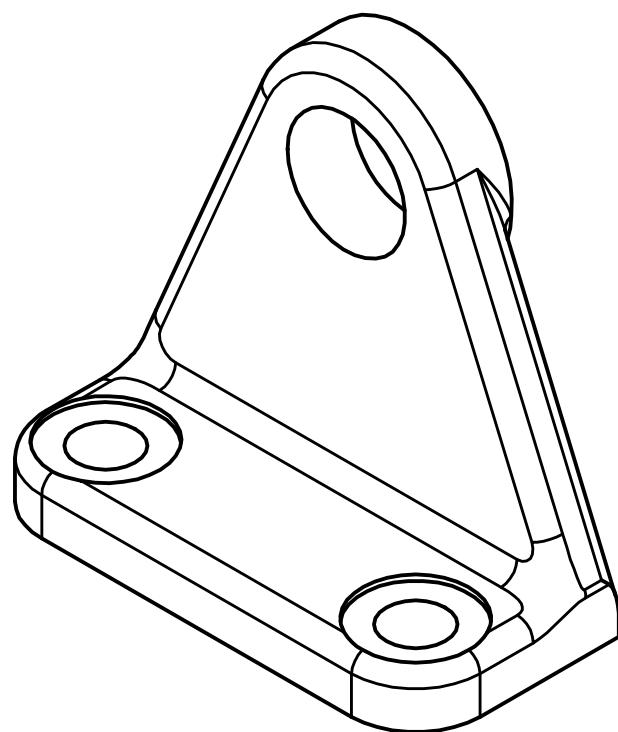
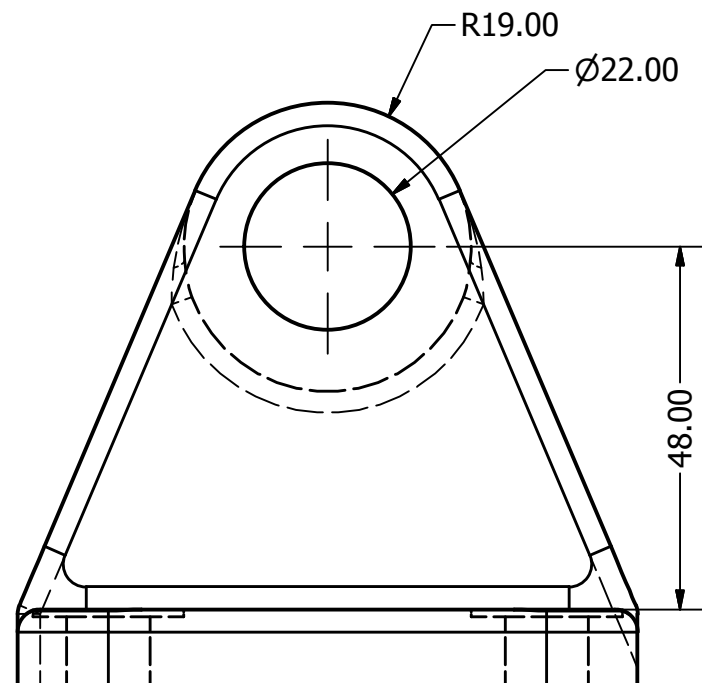
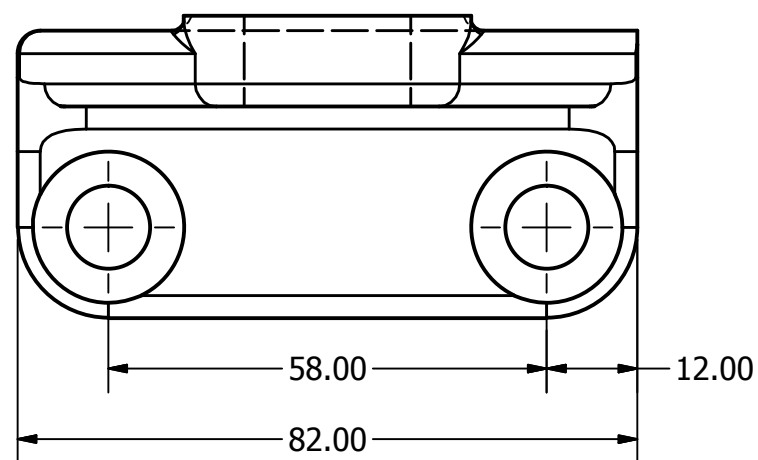

PARTS LIST			
ITEM	QTY	PART NUMBER	MATERIAL
1	1	AXLE SUPPORT	MALLEABLE IRON

AXLE SUPPORT  
SCALE 1 : 1

DRAWN ASHLEY JORGENSEN	1/26/2010	TITLE	
CHECKED		CASTER ASSEMBLY	
QA		SIZE B	DWG NO FIG. 9-51
MFG		SCALE	REV
APPROVED		SHEET 4 OF 7	

PARTS LIST			
ITEM	QTY	PART NUMBER	MATERIAL
1	1	BUSHING	BRONZE

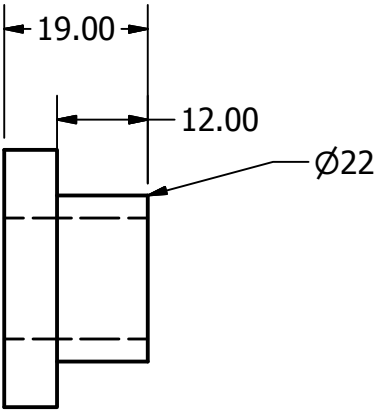
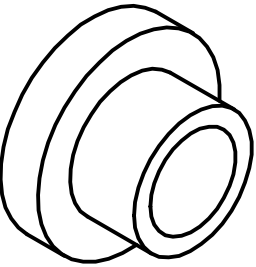

BUSHING  
SCALE 1 : 1

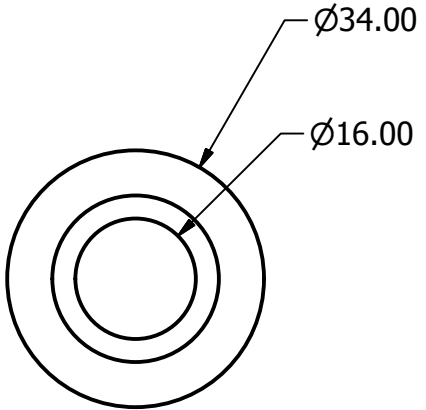

DRAWN	ASHLEY JORGENSEN	1/26/2010		
CHECKED			TITLE	
QA			CASTER ASSEMBLY	
MFG				
APPROVED				
		SIZE	DWG NO	REV
		B	FIG. 9-51	
		SCALE	SHEET 5 OF 7	

PARTS LIST			
ITEM	QTY	PART NUMBER	MATERIAL
1	1	AXLE	SAE 1020

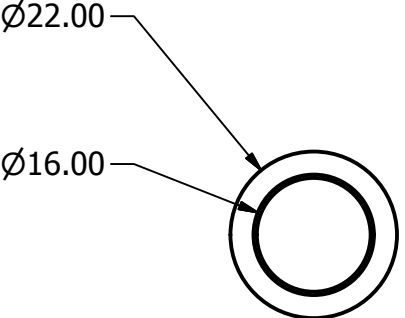
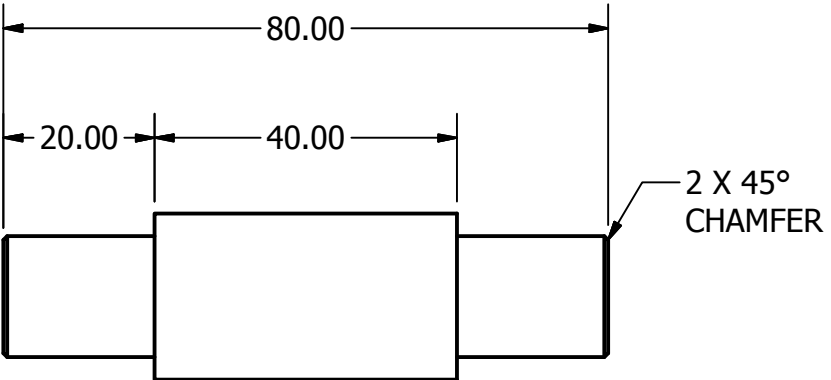
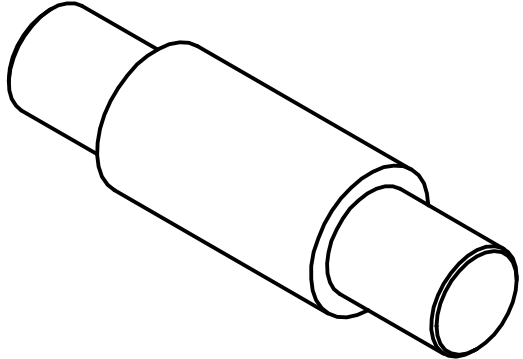

AXLE  
SCALE 1 : 1

DRAWN	ASHLEY JORGENSEN	1/26/2010		
CHECKED				
QA			TITLE	
MFG			CASTER ASSEMBLY	
APPROVED				
		SIZE	DWG NO	REV
		B	FIG. 9-51	
		SCALE	SHEET 6 OF 7	

PARTS LIST			
ITEM	QTY	PART NUMBER	MATERIAL
1	1	WHEEL	MALLEABLE IRON

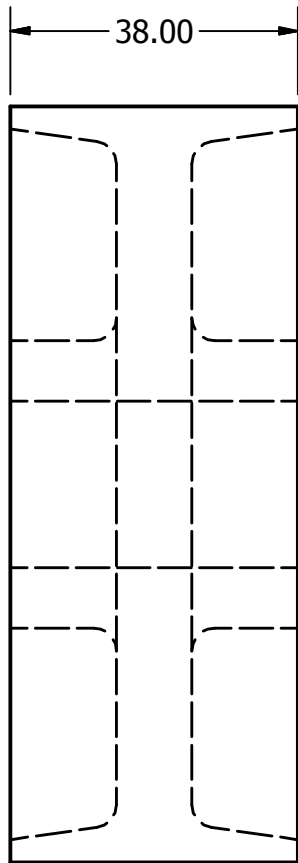
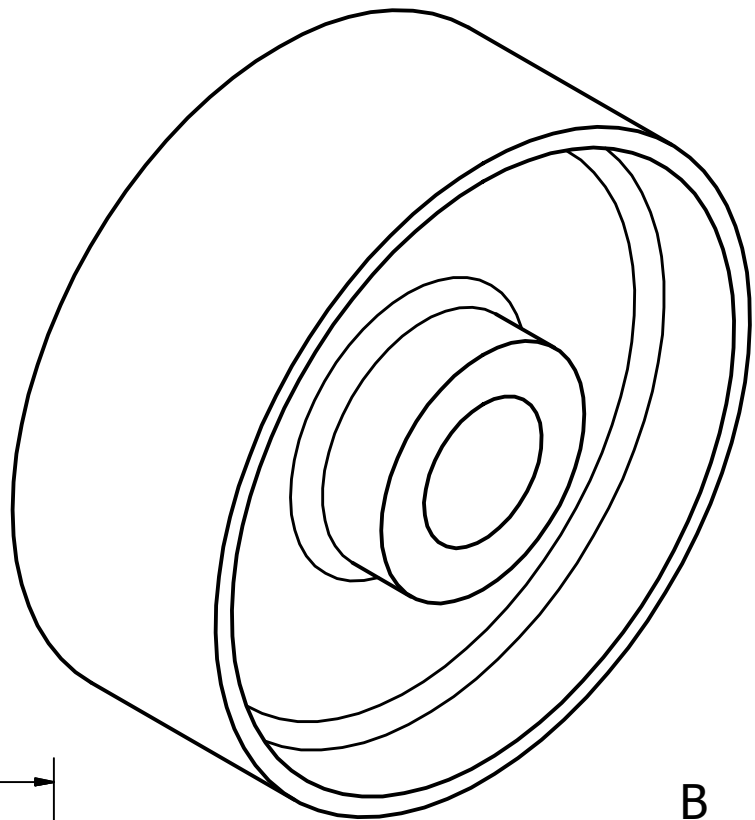

WHEEL  
SCALE 1 : 1

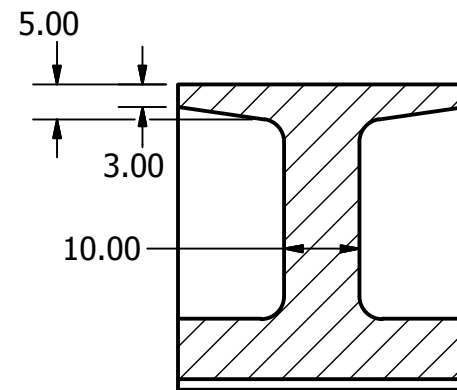
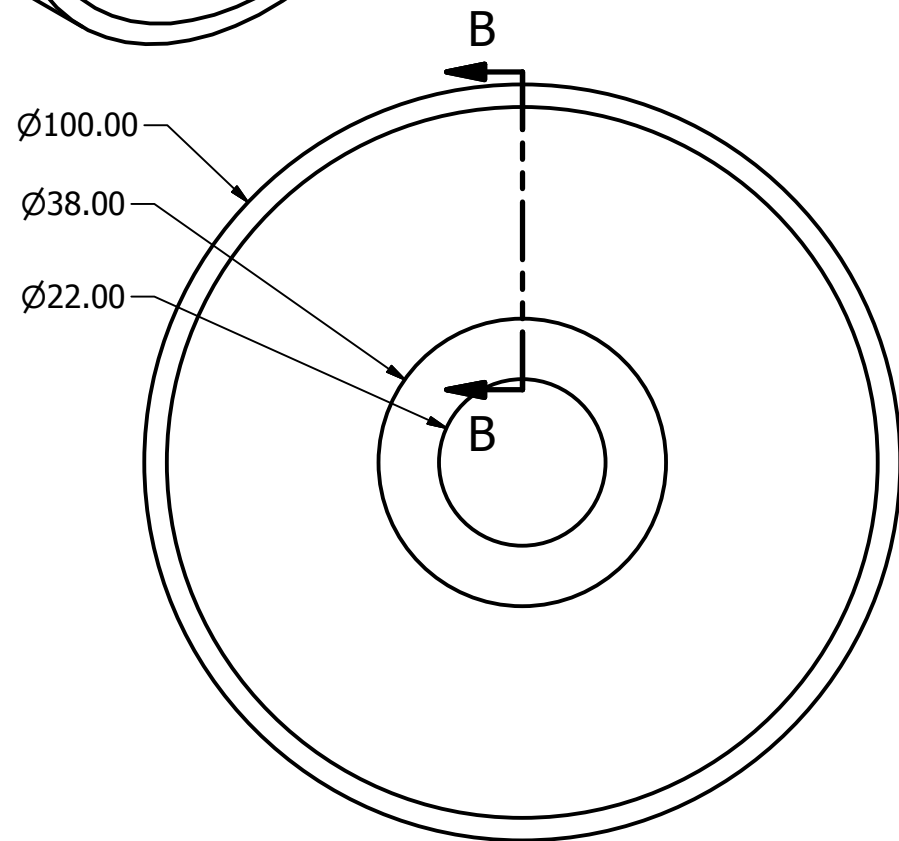

SECTION B-B  
SCALE 1 : 1

DRAWN	ASHLEY JORGENSEN	1/26/2010	TITLE	
CHECKED			CASTER ASSEMBLY	
QA			SIZE	DWG NO
MFG			B	FIG. 9-51
APPROVED			SCALE	REV
			SHEET 7 OF 7	